

DOAS/RTU Curb Dimensions

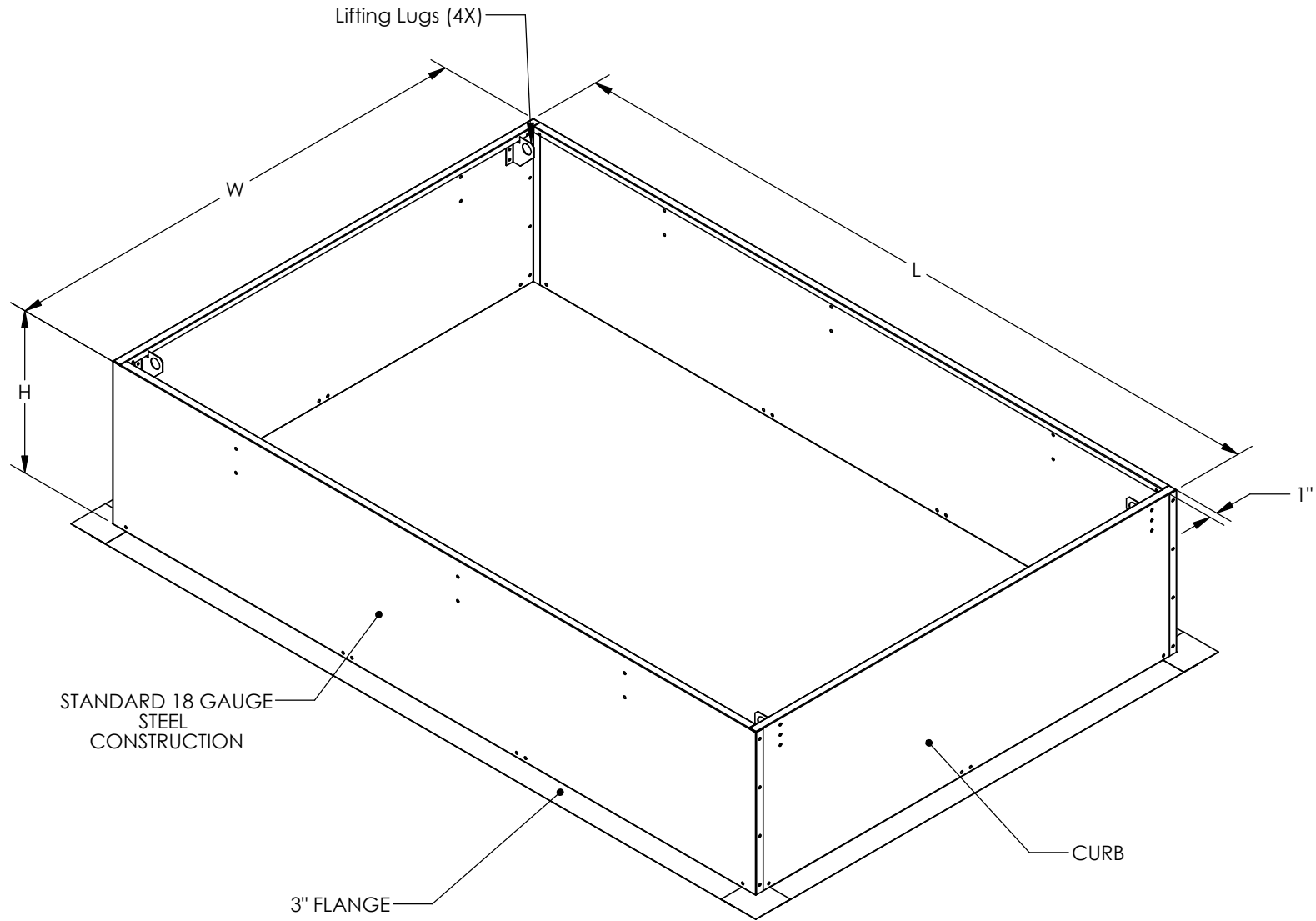

DOAS/RTU Curb Dimensions									
	SIZE 1	SIZE 2	SIZE 3	SIZE 4	Size 1 Unicurb	Size 2 Unicurb	Size 3 Unicurb	Size 4 Unicurb	Size 4 HC Unicurb
H	VARIABLE	VARIABLE	VARIABLE	VARIABLE	VARIABLE	VARIABLE	VARIABLE	VARIABLE	VARIABLE
L	71	75	91	111	111	120 1/4	142	169 1/2	210
W	41	49 1/2	59 1/2	80	41	49 1/2	59 1/2	80	80

DOAS/RTU DUCT HANGER

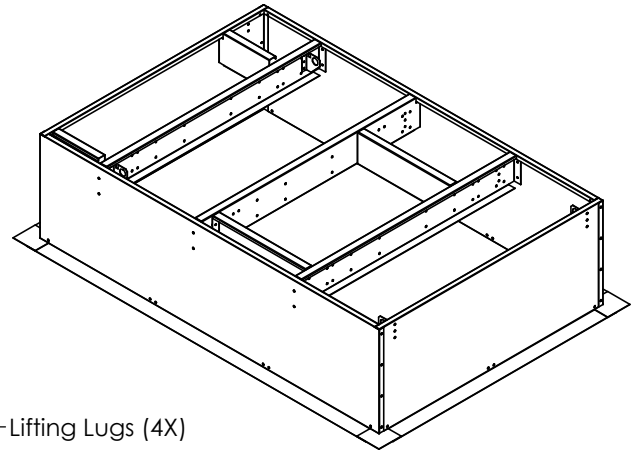
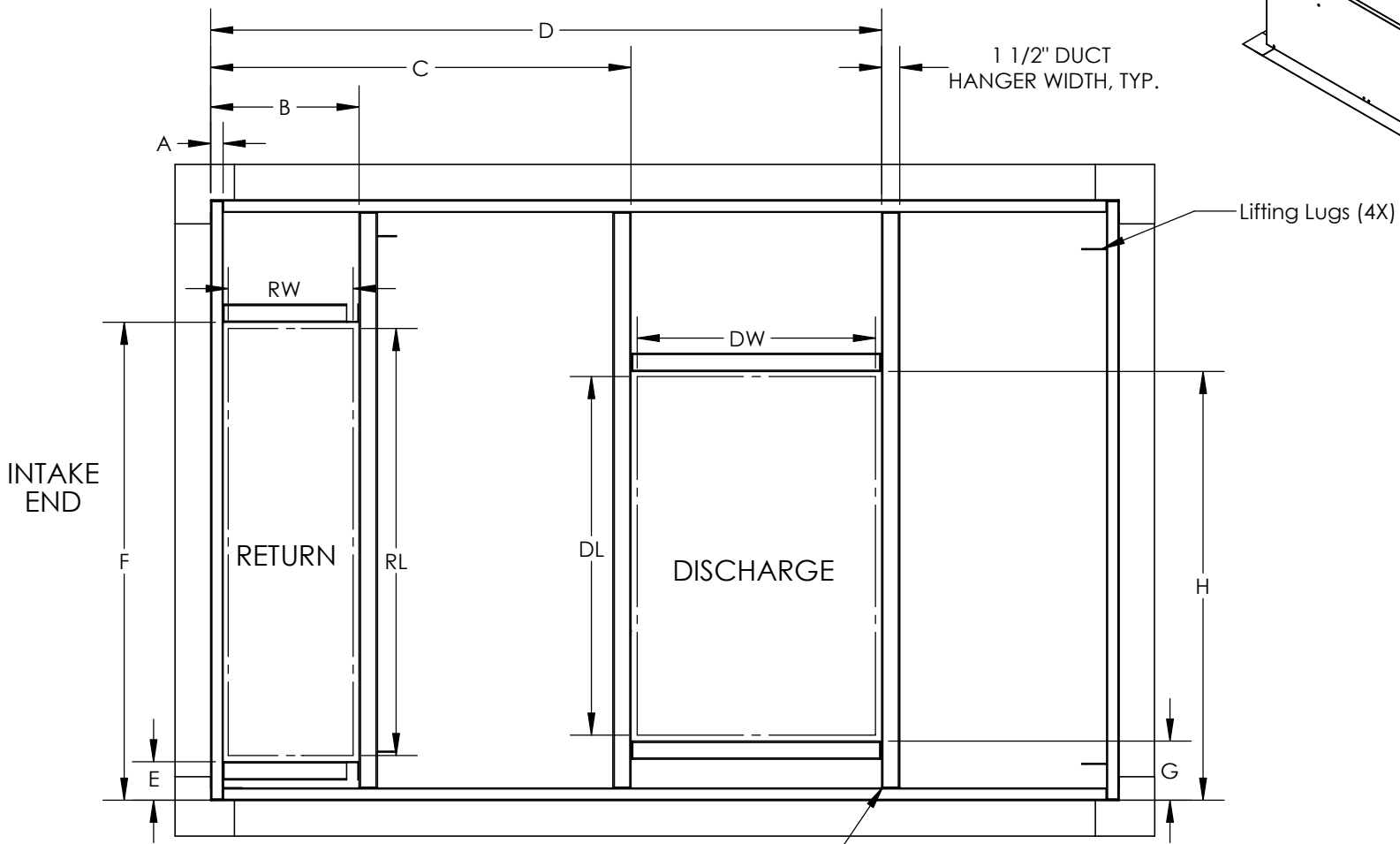

FASTEN DUCT HANGERS USING 1/4"-20x5/8" PAN HEAD PHILLIPS SCREWS (A0005680) AND NUTS (A0005690).

	DUCT DIMENSIONS (IN.)			
	SIZE 1	SIZE 2	SIZE 3	Size 4
DW	21 1/8	20 3/16	21 1/2	39 1/8
DL	21 3/4	30	38 7/8	46 1/16
RW	11 5/16	10 3/4	15 1/8	14
RL	29 3/4	36	47 1/8	77 3/4

	DOAS/RTU Curb Dimensions			
	SIZE 1	SIZE 2	SIZE 3	SIZE 4/4 HC
A	1	1	1	1
B	12 13/16	12 1/4	16 5/8	15 1/2
C	37 5/8	34 11/16	49 5/8	56 5/16
D	59 1/4	55 3/8	71 5/8	96
E	1	3 3/16	1	1
F	31 1/4	39 7/16	48 3/8	79
G	5 5/16	4 7/8	4 3/16	30 7/8
H	27 9/16	43 1/2	43 1/2	77 7/16

DOAS/ERV UNICURB DUCT HANGER

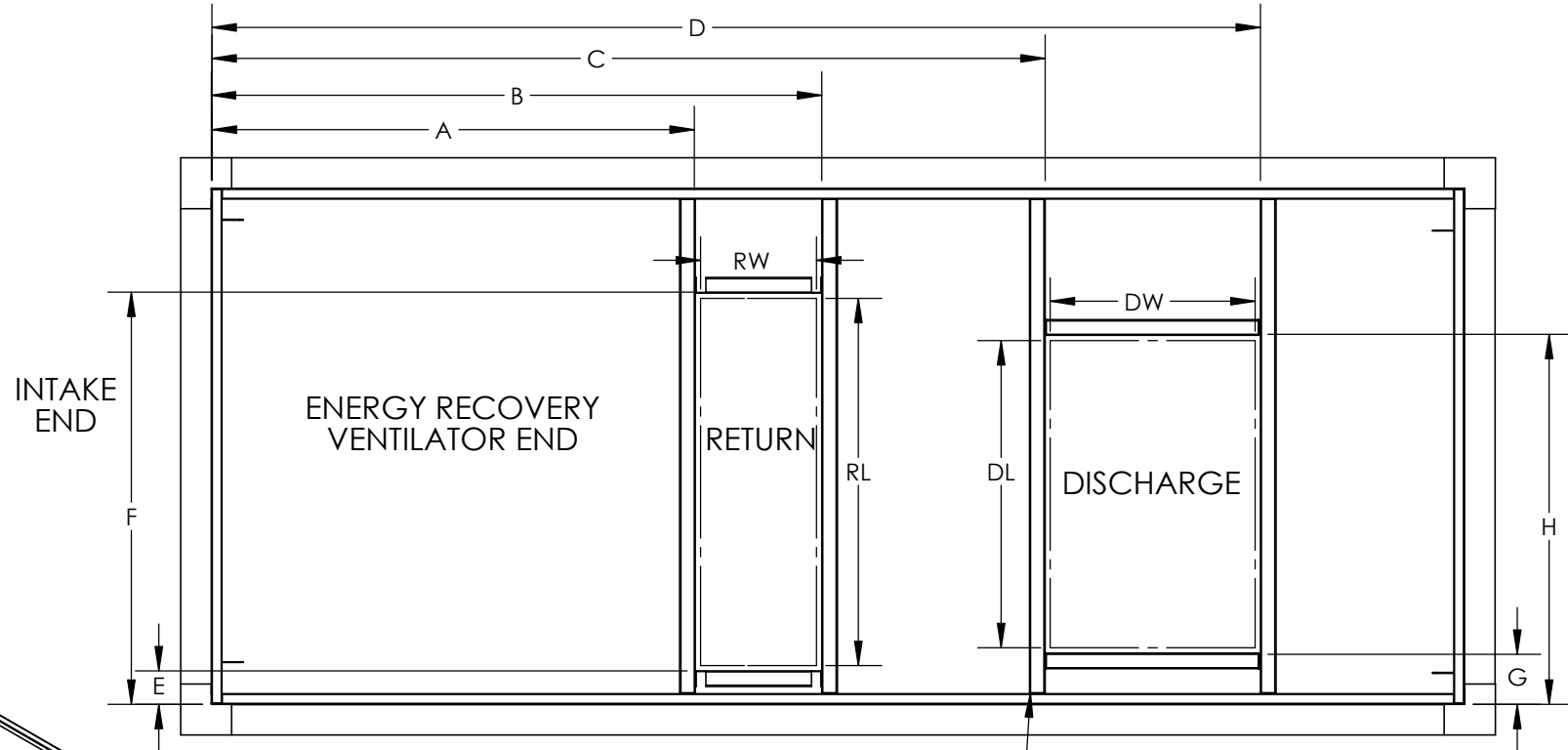

FASTEN DUCT HANGERS USING 1/4"-20x5/8" PAN HEAD PHILLIPS SCREWS (A0005680) AND NUTS (A0005690).

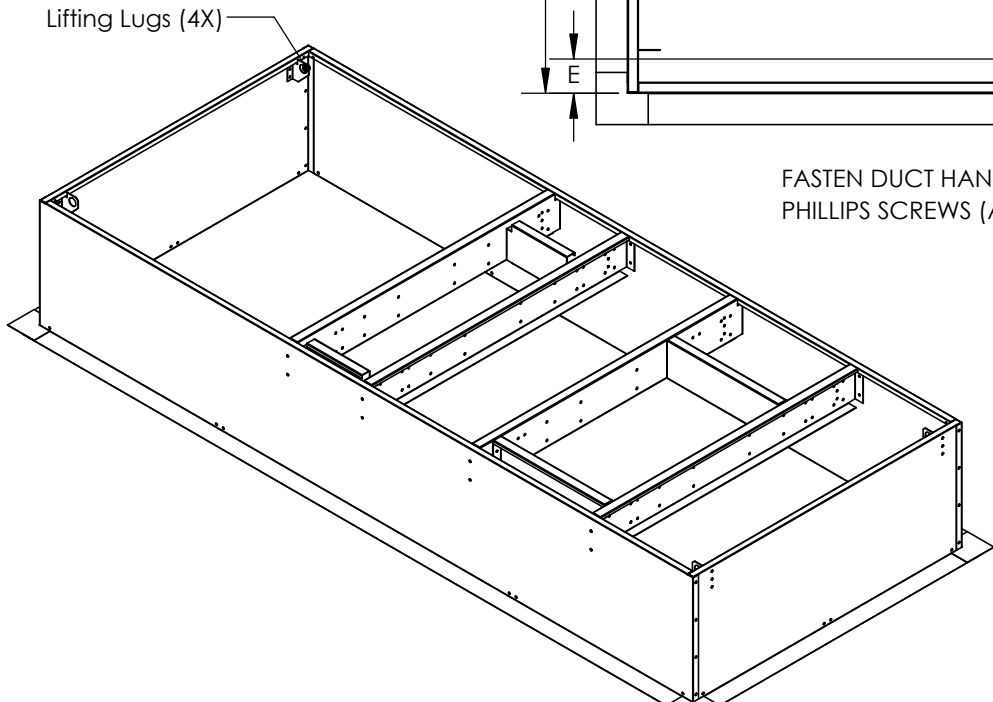

	DUCT DIMENSIONS (IN.)			
	SIZE 1	SIZE 2	SIZE 3	Size 4
DW	21 1/8	20 3/16	21 1/2	39 1/8
DL	21 3/4	30	38 7/8	46 1/16
RW	12 5/16	11 3/4	16 1/8	14
RL	29 3/4	36	47 1/8	77 3/4

** Size 2, 3, & 4 UniCurbs are built as a split curb due to their overall length

	DOAS/ERV Unicurb Dimensions				
	SIZE 1	SIZE 2	SIZE 3	SIZE 4	SIZE 4 HC
A	40 9/16	46 1/2	52 3/8	59 1/2	100
B	53 5/16	58 5/8	68 7/8	74 1/8	114 5/8
C	77 5/8	80 1/16	101 1/8	115	155 3/8
D	99 1/4	100 3/4	123 1/8	154 1/2	195
E	1	3 3/16	1	1	1
F	31 1/4	39 7/16	48 3/8	79	79
G	5 5/16	4 7/8	4 3/16	30 7/8	30 7/8
H	27 9/16	35 3/8	43 1/2	77 7/16	77 7/16