

# RTD SENSOR INSTALLATION

## Revision History

#	Description	Revised by	ECN#	Date
0	Released to Website	JTS	1772	9/8/09

NOTES: One RTD per Exhaust Fan  
 : RTD has 3 wires that connect to control cabinet

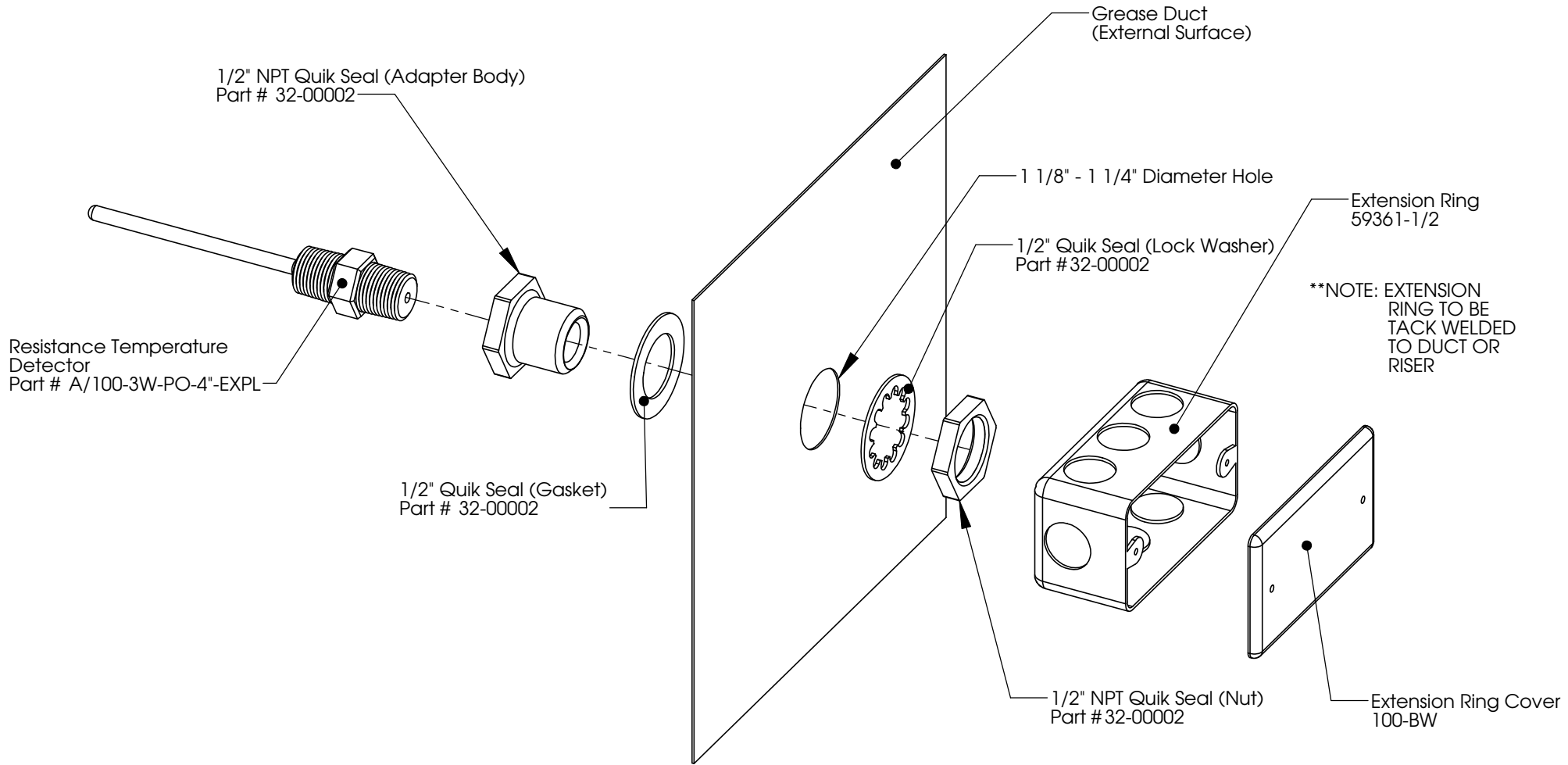

Material: N/A  
 Blank Size: N/A x N/A  
 Weight: N/A lbs

Part Number: N/A  
 MACOLA Number: N/A  
 Drawing Name: Sensor\_Install  
 Drawn By: JTS  
 Parent Assembly: RTD SENSOR  
 Sheet: 2 of 7

Unless Otherwise Specified  
 Dimensions are in Inches.  
 Standard Tolerances are:  
 Fractions: ±1/16  
 Decimal: .XX±.05  
 .XXX±.015  
 Angles: ±1°

**CONFIDENTIAL**