

Model TANK Fire Suppression Extinguishing System Installation, Operation, and Maintenance Manual

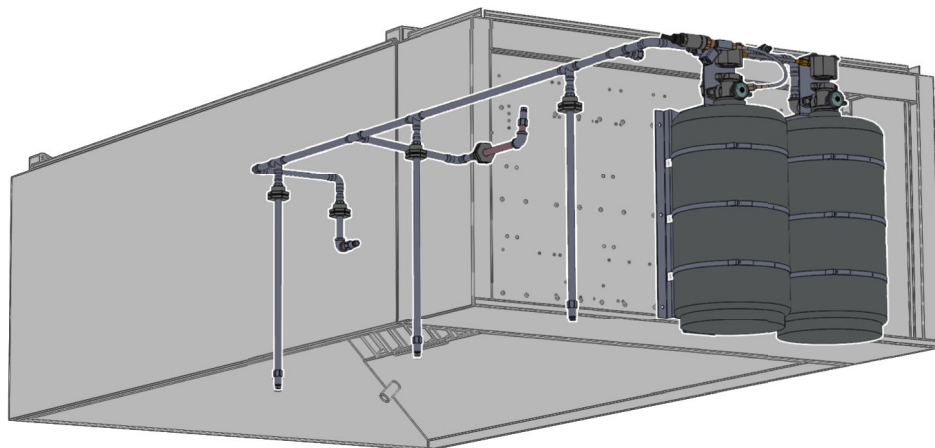

TANK Fire Suppression Extinguishing System Typical Hood End Cabinet Installation

RECEIVING AND INSPECTION

Check for any signs of damage upon receipt, and if found, report it immediately to the carrier. Check that all items are accounted for and free of damage.

WARNING!

The TANK Fire Suppression extinguishing system unit is to be installed, inspected, recharged and maintained in accordance with NFPA 17A, NFPA 96, and the National Fire Code of Canada as applicable.

Installation and maintenance of the TANK Fire Suppression extinguishing system must be performed in accordance with this manual by a factory trained distributor. Improper installation poses serious risk of injury due to electric shock and other potential hazards. Read this manual thoroughly before installing or servicing this equipment. **ALWAYS** disconnect power prior to working on equipment.

Save these instructions. This document is the property of the owner of this equipment and is required for future maintenance. Leave this document with the owner when installation or service is complete.



WARRANTY	4	Battery Backup	51
Certifications and Approvals	4	Power Supply Adjustment	51
System Overview	4	Fire Protection System Firestat	52
COMPONENTS	5	Non-Solid Fuel Appliances (Rated 450°F)	52
Cylinder Tank Assembly	6	Non-Solid Fuel Appliances (Rated 600°F)	52
Cylinder Tank and Actuator Bracket	7	Solid Fuel Appliances (Rated 700°F)	52
Discharge Adapter	7	TROUBLESHOOTING	53
Nozzles	8	CORE Board Faults	54
Primary Actuator Kit (PAK)	8	Appliance Shutdown in Fault Conditions	55
Secondary Valve Actuator (SVA) and Hose	9	Local Alarm Muting	55
Supervisory Pressure Switch	9	Test Mode	55
Gas Shut-Off Valves	10	Supervised Loop/Power Supply Troubleshooting	56
Electric Remote Manual Release	10	DIP Switch Settings	57
Firestat (Heat) Detector	10	Typical DIP Switch Arrangement	58
INSTALLATION	11	START-UP/INSPECTION TEST PROCEDURE	59
Cylinder Tanks	11	Fire System Wiring Connections	59
Removing Full Cylinder Tanks (Optional)	12	Preparing System for Test	59
Primary and Secondary Actuator Installation	12	Connecting Service Test Kit	60
Primary Actuator Kit (PAK)	13	Balloon Test Procedure	62
Secondary Valve Actuator (SVA)	13	Firestat Test Procedure	63
Supervisory Pressure Switch	14	Disconnecting Service Cylinder Tank	63
Duct and Plenum Protection	15	Re-arming System	63
Plenum Protection	15	Leakage Testing	64
Duct Protection	16	Every Month (System Owner)	65
Ventilation Exhaust and Dampers	18	Every Six Months (Factory Trained Distributor)	66
Electrostatic Precipitators (ESP)	18	Every Two Years	66
Appliance Protection	19	Every Twelve Years	66
Overlapping Appliance Protection	19	Decommissioning	66
Appliance Coverage	20	Agent Cylinder Tanks	66
Coverage Exceptions	21	Actuation Hoses	66
Overlapping Protection	22	Conditional Maintenance	67
Overlapping Coverage - Group Protection	22	Replacing A Primary Actuation Kit	67
Upright Broiler/Salamander Protection	24	Replacing A Secondary Valve Actuator	67
Appliance with Shelf	25	Adding Nitrogen to Tank(s)	68
Wok Protection	26	POST-DISCHARGE MAINTENANCE	69
Large Wok Protection	27	General Information	69
Appliance with Upright Obstruction	28	Appliance Cleanup	69
Appliance with Overhead Salamander	29	Cleaning Distribution System	69
Pizza Ovens	30	Cleaning Nozzles	69
Agent Distribution Piping	32	Flushing the Distribution Pipe Network	70
Cylinder Nozzle and Piping Parameters	34	Flushing Procedure with Spare/Test Cylinder	70
Nozzle Installation	34	Flushing Procedure with an External Water Supply	71
Gas Shut-Off Valves	35	Flush the System	71
Hood Riser Sensor Replacement	37	Dry the Lines	72
Fire Protection Manual Actuation Device	38	Cylinder Tank Maintenance	73
Trouble Input Wiring	38	Removing a Cylinder Tank (Empty or Storage)	73
Fire Protection System Printed Circuit Board	39	Install New Cylinder Tank(s)	74
Electrical	42	Depressurizing a Cylinder Tank	75
Wire Ampacity Rating	43	Rechecking the System	75
Distance Limitations	43	Mobile Kitchen/Seasonal Shutdown	76
Fire Alarm Contacts	43	TANK FIRE SUPPRESSION SYSTEM PARTS	77
Fire Group	44	Start-Up and Maintenance Documentation	80
Fire Protection System Supervised Loops	45	Job Information	80
Supervised Loop Electrical Details	46		
PCU Fire System	47		
PCU Fire System Nozzles	48		
OPERATION	49		
Test Mode Overview	50		
Reset Overview	50		

WARRANTY

Model TANK Fire Suppression extinguishing system is warranted to be free from defects in materials and workmanship, under normal use and service, for a period of 60-months from date of shipment. Warranty does not cover consumable products such as batteries and nitrogen. This warranty is null and void if:

1. The system is not installed by a factory trained installer per the MANUFACTURER'S installation instructions shipped with the product.
2. The equipment is not installed in accordance with Federal, State, Local codes, and regulations.
3. The system is misused or neglected, or not maintained per the MANUFACTURER'S maintenance instructions.
4. The system is not installed and operated within the limitations set forth in this manual.
5. The invoice is not paid within the terms of the sales agreement.

The MANUFACTURER shall not be liable for incidental and consequential losses and damages potentially attributable to malfunctioning equipment. Should any part of the equipment prove to be defective in material or workmanship within the 60-month warranty period, upon examination by the MANUFACTURER, such part will be repaired or replaced by MANUFACTURER at no charge. The BUYER shall pay all labor costs incurred in connection with such repair or replacement. Equipment shall not be returned without MANUFACTURER'S prior authorization, and all returned equipment shall be shipped by the BUYER, freight prepaid to a destination determined by the MANUFACTURER.

NOTE: To receive warranty coverage for this product, copy and print out the "Start-Up and Maintenance Documentation" on page 80. Fill in all required information. Fax the page to 1-919-516-8710 or call 1-866-784-6900 for emailing information.

Certifications and Approvals

The Tank Fire Suppression system is ETL Listed in accordance with ANSI/CAN/UL/ULC 300, ULCORD-C1254.6.

The microprocessor-based control board is ETL Listed to UL Standard 864 and CAN/ULC-S527-11.

The Tank Fire Suppression system is acceptable for use in New York City, and is approved per FDNY COA #5870.

System Overview

The Tank Fire Suppression extinguishing system provides fire protection for commercial cooking appliances and ventilation. The Tank Fire Suppression extinguishing system is electrically released via a 24V DC solenoid valve. Extinguishing system units with electrical detection, activation, and control require the use of a Listed Control Panel, which has been found acceptable for releasing device service and which is compatible with the electrical actuators used on the extinguishing system. In addition, all electrical detectors, notification devices, and pull stations are required to be Listed and compatible with the Control Panel.

COMPONENTS

The following section lists the major components used in the TANK Fire Suppression extinguishing system.

Figure 1 - Shipping/Test View

1. Unit is shown in Shipping/Test Position
2. Tank Straps
3. Tank Mounting Bracket (Secured to cabinet with rivets)
4. Cylinder Tanks (Up to four tanks may be installed depending on cabinet size.)

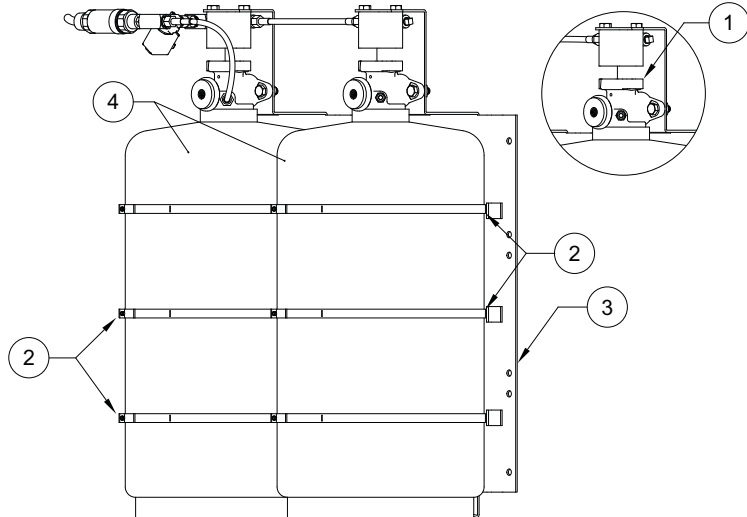
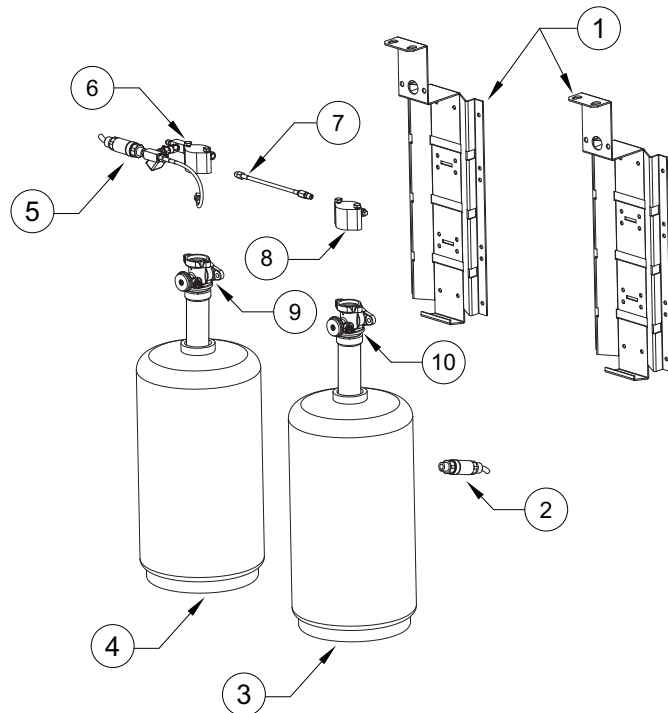

Figure 2 - Exploded View

1. Tank Mounting Brackets
 2. Secondary Supervisory Pressure Switch (Optional)
 3. Secondary Cylinder (Optional)
 4. Primary Cylinder
 5. Supervisory Pressure Switch
 6. Primary Actuator Kit
 7. Secondary Actuator Hose (Optional)
 8. Secondary Valve Actuator (Optional)
 9. Primary Valve with Siphon Tube
 10. Secondary Valve with Siphon Tube (Optional)
- Tank straps not shown.



NOTE: Tanks should never be filled with agent in the field.

Cylinder Tank Assembly

The TANK Fire Suppression cylinder assembly (p/n 87-300001-001) uses a mild steel cylinder, conforming to 4BW250 DOT & 4BWM-17 TC specifications, and a nickel-plated brass valve with pressure indicator gauge. Each valve includes a Schrader valve for connection to the primary actuator hose (for primary cylinders) or the supervisory pressure switch (optional for secondary cylinders).

Each cylinder assembly is factory-filled with TANK liquid fire suppressant and pressurized to 200 psig (1379 kPa) at 70°F (21°C). Each cylinder supports up to 5 nozzles for a total of 20 flow points.

Figure 3 - Cylinder Tank Details

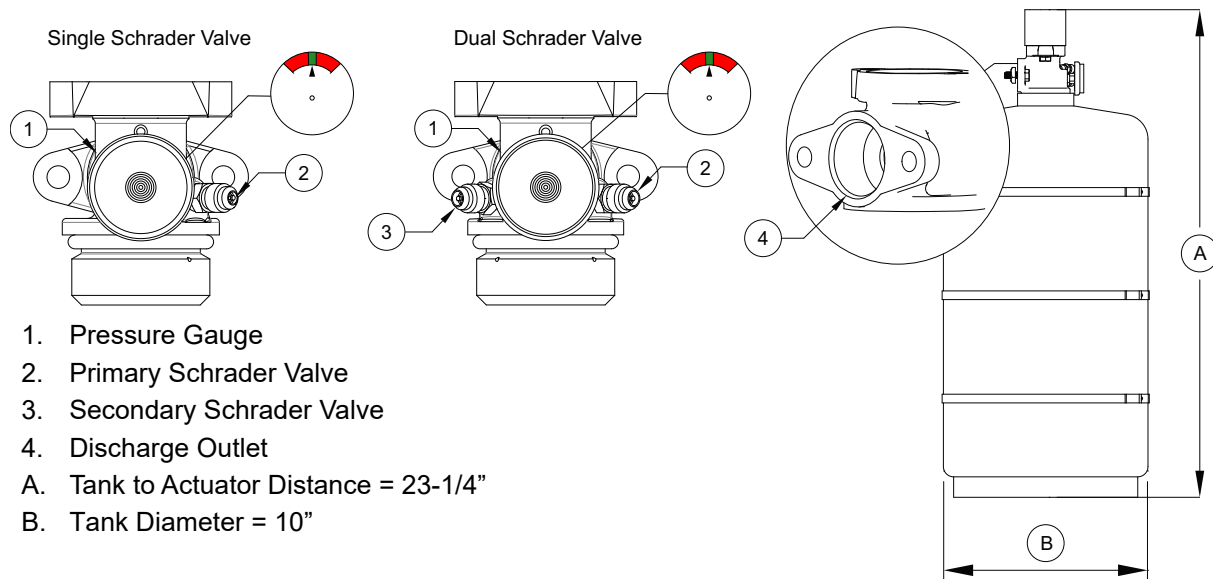

1. Pressure Gauge
2. Primary Schrader Valve
3. Secondary Schrader Valve
4. Discharge Outlet
- A. Tank to Actuator Distance = 23-1/4"
- B. Tank Diameter = 10"

The pressure of a cylinder will vary with the ambient temperature, as detailed in **Table 1**. The gauge indicator (shown in **Figure 3**) should be in the acceptable 'green' range for a cylinder that is properly pressurized and within the listed operating temperature range. For a cylinder at the lowest listed operating temperature of 32°F (0°C), the pressure gauge should read approximately 175 psig (the lower end of the green range). For a cylinder at the highest listed operating temperature of 130°F (54.4°C), the pressure gauge should read approximately 225 psig (the upper end of the green range).

NOTE: The agent itself may be stored down to -20°F (not operational system temperature).

Table 1 - Cylinder Temperature Vs Pressure

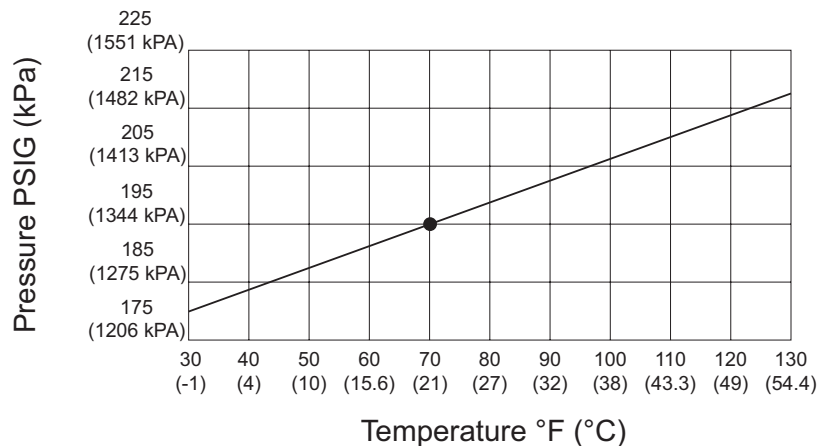

Cylinder Tank and Actuator Bracket

Each cylinder assembly is secured to a factory-installed cylinder bracket in the cabinet (p/n TFS-UCTANKBRACKET). The cylinder is secured to the cylinder bracket via three (3) stainless steel straps.

The cylinder bracket also includes a platform for securing a primary actuator kit or secondary valve actuator during shipping and maintenance procedures.

Figure 4 - Cylinder Tank and Actuator Bracket

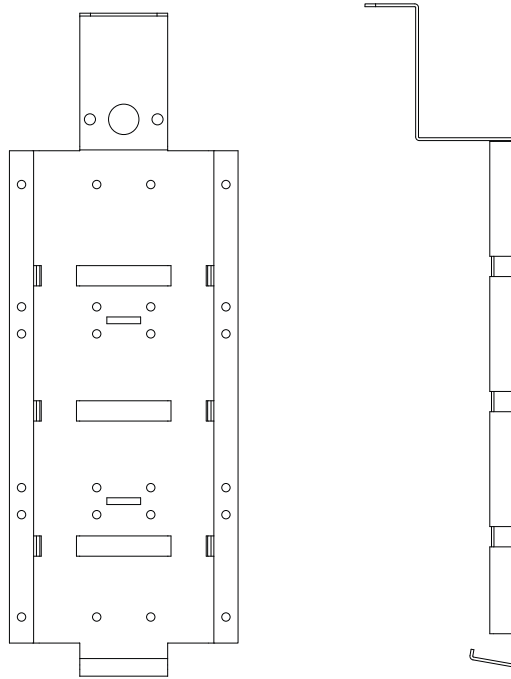

Discharge Adapter

The discharge adapter (p/n WK-283952-000) is used to connect the TANK Fire Suppression cylinder valve outlet to the agent distribution pipe network. The 1/2-inch NPT internal thread of the discharge adapter outlet is connected to the supply line via an elbow and adapter.

The discharge adapter uses an O-ring (p/n WK-108019-000) at the valve port to eliminate leaks during discharge.

Figure 5 - Discharge Adapter

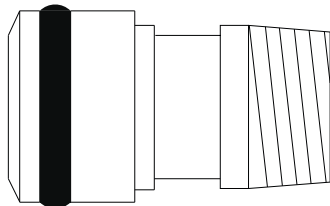

Nozzles

The Overlapping Female Nozzle(s) (p/n OL-F) are used for plenum, duct, overlapping appliance protection, and dedicated appliance coverage (e.g., salamanders, upright broilers, chain broilers, and appliance with upright obstructions). The nozzles include a cap (p/n 3074-1-1). The cap prevents contamination from entering the pipe network and is designed to pop-off upon system discharge, allowing the agent to flow to the protected hazard area. Refer to **“Duct and Plenum Protection” on page 15.**

Figure 6 - Fire System Nozzle

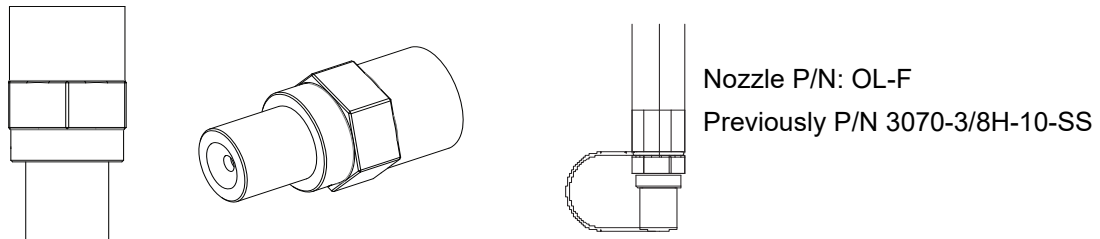

Primary Actuator Kit (PAK)

The Primary Actuator Kit (PAK) (p/n 87-300030-001) is installed on each primary cylinder assembly to pneumatically open the cylinder valve and provide actuation pressure for up to three secondary valve actuators. A vent limiting orifice is present to allow easier resetting of SVA pistons during inspections.

The PAK consists of a pneumatic actuator, 24V DC solenoid valve, solenoid strainer (recommended by the manufacturer), check valve, primary actuator hose, and associated fittings.

When activated, through automatic or manual system actuation, the control panel sends a momentary 24V DC release signal. The solenoid strainer will filter out debris from entering the system. The PAK solenoid will open, allowing pressure from the primary cylinder to pass through the solenoid and check valve. The pressure flows into the primary actuator (actuating the primary cylinder), and into the interconnected secondary valve actuators (actuating the secondary cylinders).

The primary actuator has a 1/8" NPT inlet port for connection to the primary system cylinder, and a 1/8" NPT outlet port for connection to the secondary cylinder actuation line or actuation line vent limiting orifice for single cylinder system. The primary actuator includes a piston with a spring-loaded locking pin which locks the piston in the discharge position, ensuring complete discharge of the cylinder contents. When testing/inspecting, if a component fails inspection, replace the PAK assembly.

Figure 7 - Primary Actuator Kit

1. Schrader Service Valve
2. Check Valve
3. Solenoid Valve
4. Supervisory Pressure Switch Connection
5. Solenoid Strainer (internal to assembly)
6. Knurled Fitting
7. Primary Actuator
8. Primary Actuator Hose (Stainless Steel)
9. Locking Pin
10. Piston
11. Hex Fitting
12. Vent Limiting Orifice

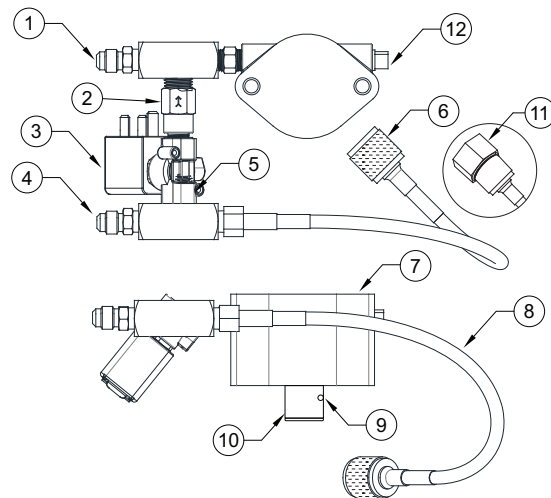

NOTE: The primary supervisory pressure switch is standard on primary tanks. Secondary supervisory pressure switches are optional on secondary tanks.

Secondary Valve Actuator (SVA) and Hose

A Secondary Valve Actuator (SVA) (p/n 87-120042-001) is installed on each secondary cylinder assembly to pneumatically open the cylinder valve(s). The SVA has 1/8" NPT inlet and outlet ports for connection to the system actuation line via the SVA hose. All secondary hoses require a 1" minimum bend radius. The SVA includes a spring-loaded locking pin that locks the actuator piston in the discharge position, ensuring complete discharge of the cylinder contents.

Figure 8 - Secondary Valve Actuator

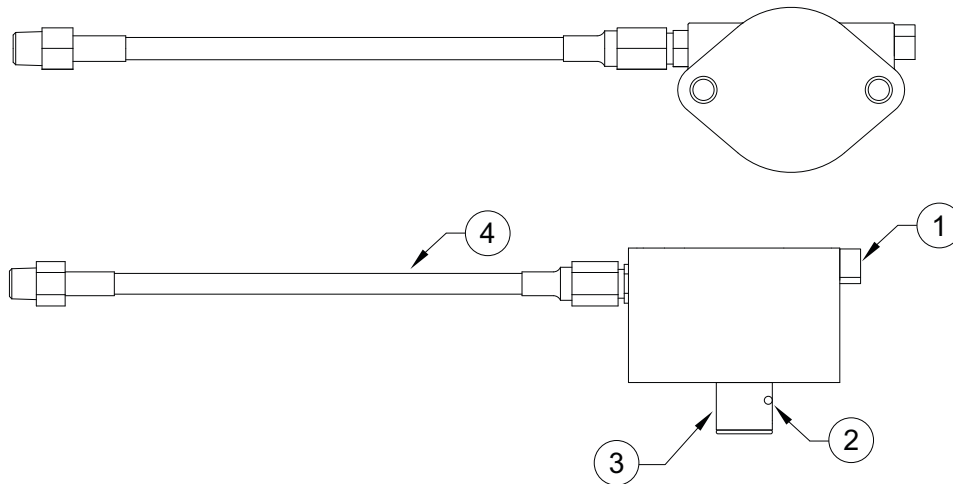

1. Vent Limiting Orifice
2. Locking Pin
3. Piston
4. Secondary Valve Actuator Hose
 - 7.5" hose option (p/n 87-120045-001)
 - 24" hose option (p/n 87-120045-002)
 - 60" hose option (p/n 87-120045-003)

Supervisory Pressure Switch

The primary and (optional) secondary supervisory pressure switch (p/n 87-300040-001) are preset to alarm at a cylinder pressure of ~10% below the lowest operating system pressure of 175 psig (pressure at the lowest listed operation temperature of 32°F). The supervisory pressure switch uses a diaphragm sensor to detect pressure changes. At the predetermined set point, the unit actuates a SPDT snap-acting switch, converting a pressure signal into an electrical signal. The supervisory pressure switch can be used on primary and/or secondary cylinders. For primary cylinders, the pressure switch is mounted on the primary actuator kit. For secondary cylinders, the pressure switch is mounted on the Schrader fitting installed on the cylinder valve. Apply Leak Lock joint sealing compound on the sealing surface of the Schrader valve when connecting/replacing the supervisory pressure switch.

Figure 9 - Supervisory Pressure Switch

1. Supervisory Pressure Switch (Primary)
2. Wrench Flats
3. Secondary Supervisory Pressure Switch (Optional)
4. Schrader Valve

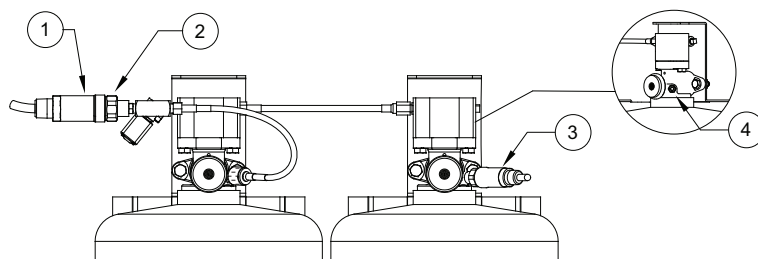

Gas Shut-Off Valves

Electric gas shut-off valves are used to shut down the flow of fuel gas to the kitchen appliances upon actuation of the TANK Fire Suppression system. An energized solenoid is used to hold the gas valve in the open position. The solenoid closes the valve when de-energized via the output relay of the control panel. The gas valves are available in 120V AC and 24V DC, ranging from 3/4" to 3" pipe sizes (**Table 2**).

Table 2 - Electric Gas Valves

Size	P/N (ASCO) 120V AC	P/N (ASCO) 24V AC
3/4"	8214235	8214G236-24VDC
1"	8214250	8214G251-24VDC
1-1/4"	8214265	8214G266-24VDC
1-1/2"	8214275	8214G276-24VDC
2"	8214280	8214G281-24VDC
2-1/2"	8214290	-
3"	8214240	-

Electric Remote Manual Release

An electrically operated manual release that is listed must be used with the TANK Fire Suppression extinguishing system. The electric remote manual release is used to actuate the TANK Fire Suppression extinguishing system manually and must be properly located and supervised in accordance with NFPA 17A and NFPA 96.

Firestat (Heat) Detector

The Firestat (Fenwal Detect-a-Fire) is a listed electric thermal detector available in a variety of temperature settings and used to actuate the TANK Fire Suppression extinguishing system automatically. When a Firestat senses a temperature higher than its setpoint, the Firestat contacts will close and energize the TANK Fire Suppression system via the control panel.

Figure 10 - Firestat

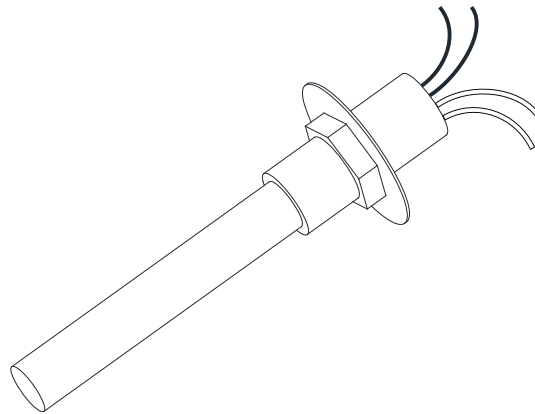

INSTALLATION

The extinguishing system consists of pressurized agent storage cylinders tanks, agent distribution piping, valve actuators, supervisory pressure switches, and agent discharge nozzles. All primary components and piping are factory-installed. Systems may be comprised of single or multiple cylinders depending on the size and configuration of the protected hazards.

Cylinders can be piped independently, or manifolded. On two-cylinder systems, the cylinders will be in a manifold configuration. Refer to “**Agent Distribution Piping**” on page 32 for a two-cylinder system example. On three-cylinder systems, two cylinders will be in a manifold configuration and one independent. On four-cylinder systems, there will be two separate manifolds.

In a fire condition or upon manual actuation, the solenoid valve is opened, allowing pressure from the primary cylinder to flow to the primary and secondary cylinder valve actuators, opening the cylinder valves and discharging liquid fire suppressant to the protected hazard areas.

WARNING!
System must be installed and operated in a conditioned space between 32°F and 130°F.

Figure 11 - Cylinder Assemblies

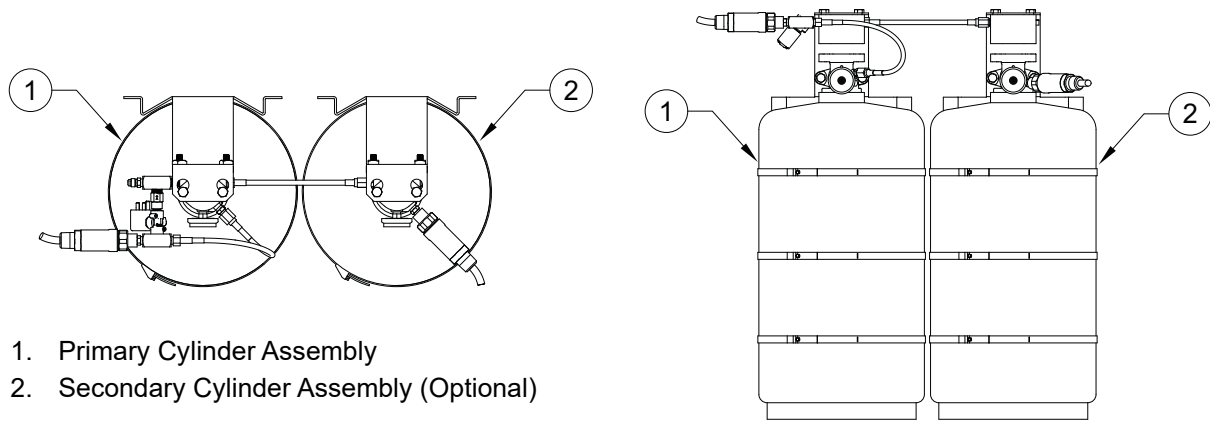

Cylinder Tanks

Cylinders are typically factory-installed, pressurized, and may be located anywhere within the hood end cabinet.

Additional cylinders may be field installed, as needed, in the additional hood end or wall mount cabinet. **Figure 12** shows a dual cylinder system mounted to the right of the hood control unit. Each cylinder assembly is secured to a factory-installed cylinder bracket in the hood end cabinet. The cylinder is secured to the cylinder bracket via three (3) stainless steel straps.

Figure 12 - Dual Cylinder Mounted in Cabinet

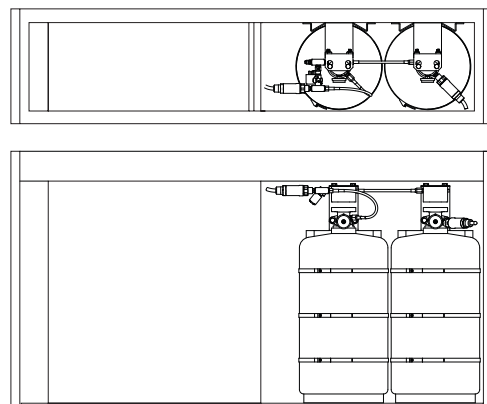

Right side cabinet mount shown.

Removing Full Cylinder Tanks (Optional)

When installing the hood, to reduce weight, you may remove the cylinder(s).

1. Verify the actuators are in the shipped position (**Figure 14**). If the system contains multiple tanks, check all additional actuators.
2. Use a 1/2" and 9/16" box end wrench to remove the two mounting bolts holding the tank on the bracket.
3. Loosen the straps.
4. Remove the tanks. Repeat for additional tanks.
5. Always reinstall tank(s) after the hood is secured. Refer to "Install New Cylinder Tank(s)" on page 74.

NOTE: When tightening the tank straps, use zip ties to secure excess banding.

Figure 13 - Removing Full Cylinders

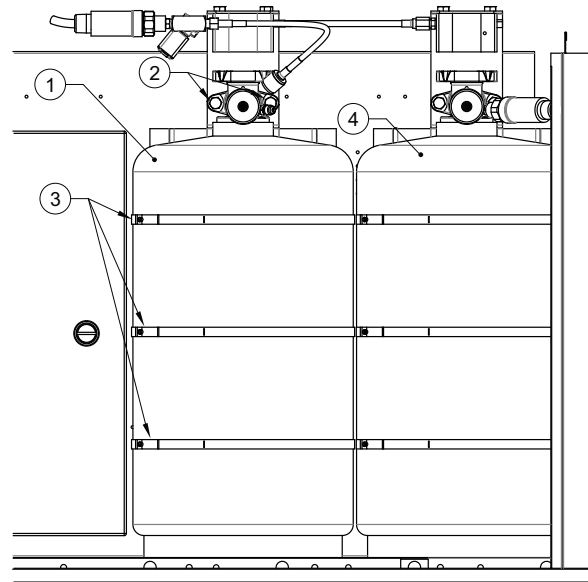

- | | |
|-------------------|--------------------------|
| 1. Cylinder 1 | 3. Cylinder Straps |
| 2. Mounting Bolts | 4. Cylinder 2 (Optional) |

Primary and Secondary Actuator Installation

WARNING!

Do not complete PAK or secondary valve actuator installation until system test and commissioning are complete. The cylinder bracket includes a platform for securing a primary actuator kit or secondary valve actuator during shipping and maintenance procedures. The system actuators must be in the ship/test position for all commissioning and test procedures. Testing with actuators in place will result in discharge of the agent cylinders.

Refer to "START-UP/INSPECTION TEST PROCEDURE" on page 59 for the testing and commissioning unit.

Figure 14 - PAK in Ship/Test and Installed Positions

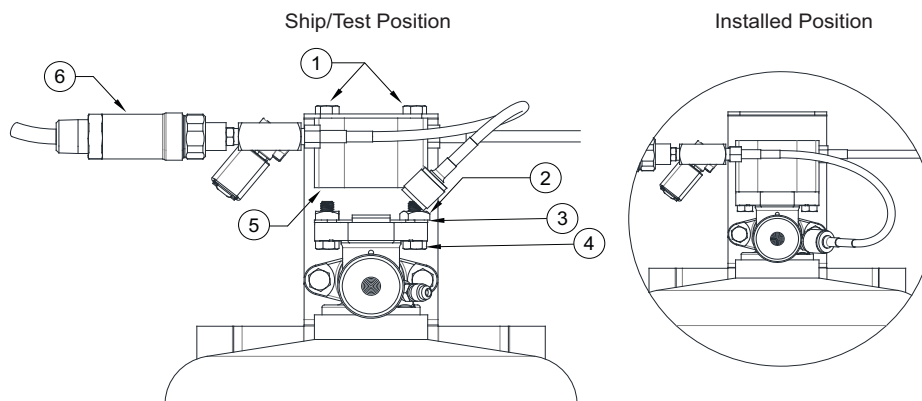

- | | |
|---------------------------|---|
| 1. Shipping Bolts | 4. Mounting Bolts |
| 2. Nut | 5. Primary Actuator Kit (In Transport Position) |
| 3. Valve Protection Plate | 6. Supervisory Pressure Switch |

Primary Actuator Kit (PAK)

The primary actuator kit is mounted to the primary cylinder bracket during shipment and when testing the system. With the cylinders securely mounted and connected to the system piping, the primary actuator kit can be installed onto the primary cylinder for the final setup.

1. Remove the valve protection plate and nuts. Retain the mounting bolts for installation of the PAK.
2. Ensure the primary actuator piston is in the set position.
3. Loosen the PAK shipping bolts from the top of the bracket, slide the unit back and lower it into position on the valve actuation flange.
4. Insert the mounting bolts through the bottom of the valve flange into the PAK mounting holes and tighten securely.
5. Connect the primary actuator hose to the Schrader valve on the primary cylinder valve. The primary hose requires a 1.5" minimum bend radius.

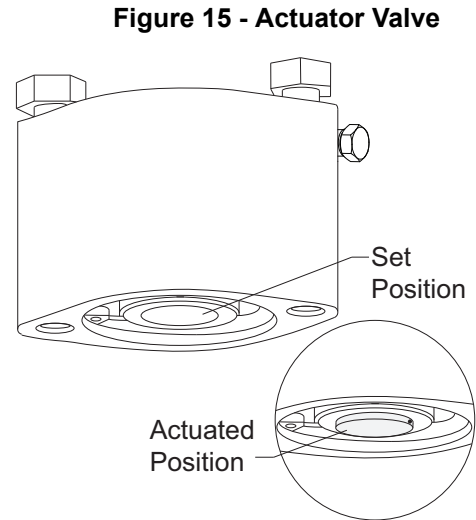

WARNING!

Installation of the primary actuator hose is the FINAL step performed.

Connecting this hose earlier may result in accidental system discharge. Refer to "START-UP/ INSPECTION TEST PROCEDURE" on page 59 for the testing and commissioning procedure.

When inspecting the primary actuator hose, replace O-ring. Refer to "TANK FIRE SUPPRESSION SYSTEM PARTS" on page 77.

The primary and secondary actuation hoses cannot be interchanged. The primary actuation hose must be used with the PAK.

Secondary Valve Actuator (SVA)

With the cylinders securely mounted and connected to the system piping, the secondary valve actuators (SVA) can be installed onto each of the secondary cylinder(s).

1. Remove the valve protection plate and nuts. Retain the mounting bolts for installation of the SVA.
2. Loosen the SVA shipping bolts from the top of the bracket, slide the unit back and lower it into position on the valve actuation flange.
3. Insert the mounting bolts through the bottom of the valve flange into the SVA mounting holes and tighten securely.
4. Ensure the secondary actuator hose is securely connected to the primary actuator output port and SVA input port.

Key Limitations

- Total length of secondary actuation flex hose must not exceed 75" of flex hose. Refer to "**Secondary Valve Actuator (SVA) and Hose**" on page 9 for secondary hose information.
- Secondary actuator hose(s) require 1" minimum bend radius.
- Maximum number of secondary valve actuators operating from the primary actuator unit is three (3).

WARNING!

The Valve Protection Plate must remain on the valve actuation port until the valve actuator is installed.

The primary and secondary actuation hoses cannot be interchanged. The secondary actuation hose (7", 24" or 60" length) must be used with secondary valve actuators.

Supervisory Pressure Switch

A supervisory pressure switch will always be located on the primary cylinder by the Primary Actuator Kit (PAK). For secondary cylinders, this is an optional component that may be added on. For primary cylinders, the pressure switch is mounted on the primary actuator kit. For all secondary cylinders, the pressure switch is mounted on the Schrader fitting on the cylinder valve.

1. Remove cap from applicable Schrader fitting.
2. Thread the switch onto the Schrader using the brass wrench flats only.
3. Apply Leak Lock joint sealing compound on the sealing surface of the Schrader valve when connecting/replacing the supervisory pressure switch, and PAK hose.

Figure 16 - Supervisory Pressure Switch Installation

1. Supervisory Pressure Switch (Primary)
2. Wrench Flats
3. Schrader Valve
4. Optional Secondary Supervisory Pressure Switch

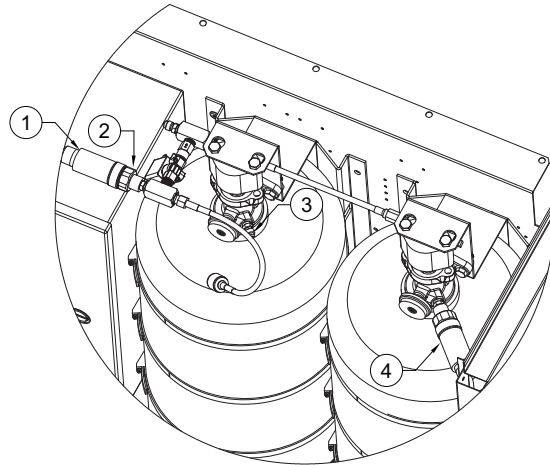

WARNING!

Proof pressure (*) limits stated on the nameplate must never be exceeded, even by surges in the system. Occasional operation of unit up to proof pressure is acceptable (e.g., start-up, testing). Continuous operation should not exceed the designated over range pressure ().**

***Proof pressure - the maximum pressure to which a pressure sensor may be occasionally subjected, which causes no permanent damage (e.g., start-up, testing).**

****Over Range Pressure - the maximum pressure to which a pressure sensor may be continuously subjected without causing damage and maintaining set point repeatability.**

NOTE: Pressure switches do not contain any field replaceable parts. Refer to applicable control panel manual for wiring of the supervisory pressure switch. Wire in accordance with local and national electrical codes.

WARNING!

Disconnect all supply circuits before wiring pressure switch. Electrical ratings stated in literature and on nameplate must not be exceeded - overload on a switch can cause failure on the first cycle.

The electrical rating is rated to 5A resistive and 3A inductive at 30V DC; gold flashing over silver contact for loads down to 1mA at 24V DC.

Wiring Color Code
Red
Black
White

Terminals
NO (NC under Pressure)
NC (NO under Pressure)
Com

Supervisory pressure switches are connected in series to the control panel supervisory input.

Duct and Plenum Protection

The TANK Fire Suppression extinguishing system for duct and plenum coverage can be provided by independent fire suppression tanks and piping or integrated with the fire suppression tanks and piping used for protection of the appliances. Max of 5 nozzles per TANK for duct and plenum coverage only. Each duct and plenum nozzle protection is 4 flow points.

Plenum Protection

The nozzle(s) (**page 8**), are used to protect plenum areas in both single bank and V-bank plenum configurations. The nozzle will protect up to a 4' wide x 10' long plenum section. For larger plenum areas, additional nozzles are added as required, with each nozzle protecting no more than a 4' wide by 10' long plenum section. Nozzles may be installed pointing in the same direction, and/or at opposite ends of the plenum, pointing toward each other. The nozzles must not be installed back-to-back when protecting plenum areas. When positioned at the end of the plenum, nozzles must be installed from 0 to 6" into plenum.

If the riser is not centered on the plenum, the plenum nozzle is placed on the side of the plenum closest to the riser.

The nozzle locations for plenum protection are shown in **Figure 17** and **Figure 18**.

Figure 17 - Single Bank Filter Plenum

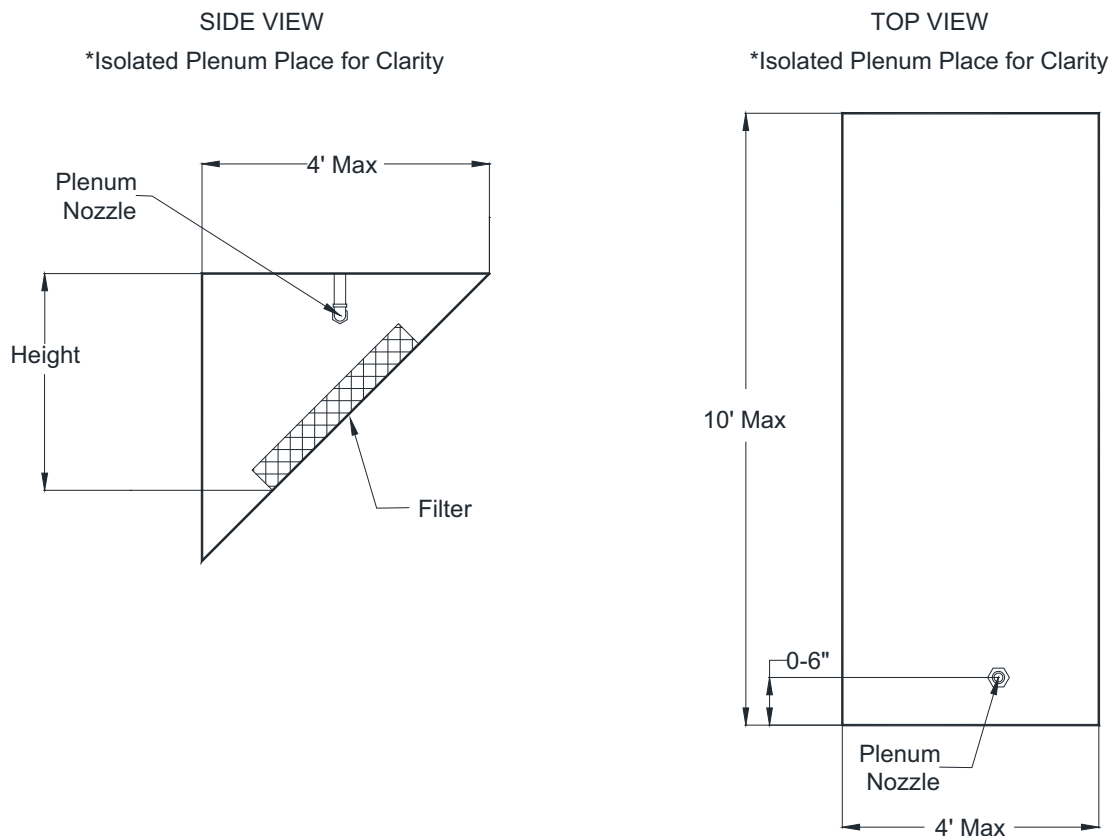
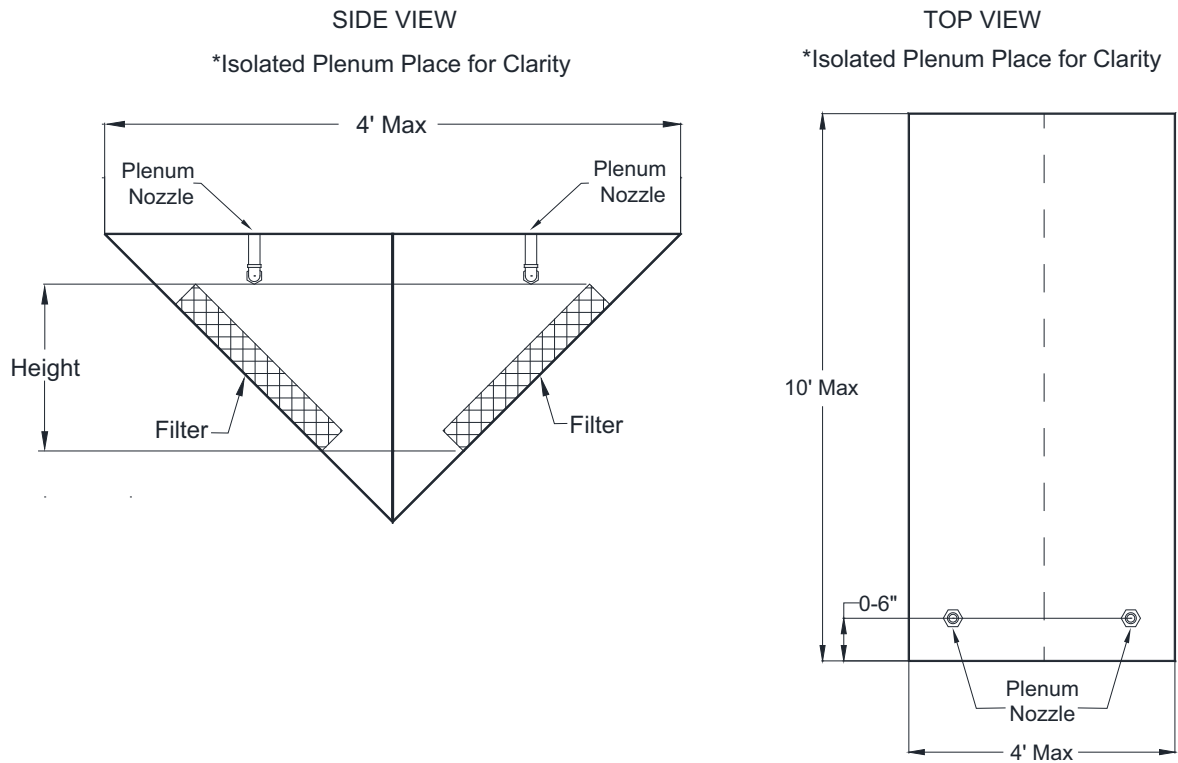

Figure 18 - Dual V-Bank Filter Plenum



Duct Protection

The nozzle(s) (page 8) is used for the protection of exhaust ductwork and can protect any duct cross-section type (e.g. round, square, or rectangular). A sufficient quantity of nozzles must be provided to ensure that no single nozzle coverage exceeds 75" in perimeter.

A single nozzle will protect a duct up to 75" perimeter (22" nominal diameter) and unlimited length. Two nozzles are required for protection of 75-150" perimeter and unlimited length. A minimum of 3 nozzles is required for protection of ducts exceeding 150" perimeter (36" nominal diameter) and unlimited length.

When using multiple nozzles (modular protection), the coverage area for each nozzle must not exceed 75" perimeter.

Figure 19 - Nozzle Duct Protection

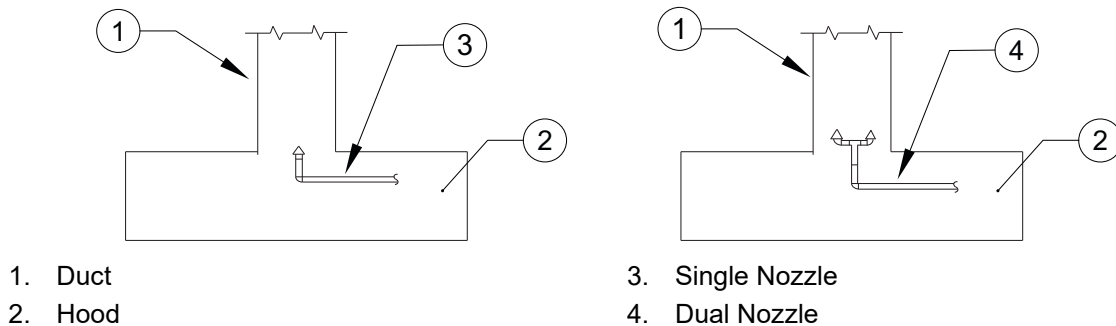

Nozzles must be installed from 0" to 6" into the protected area of the duct. When more than one nozzle is required (modular protection), each nozzle must be located at the center of its protected module area. Additional nozzles are not required for changes in direction*. Duct obstructions and common ductwork must be protected in accordance with this manual, NFPA 17A and NFPA 96.

The nozzle location and aim for duct protection are shown in **Figure 20** and **Figure 21**.

*When a change in direction occurs less than 6" from the duct entrance, the nozzle must be aimed as shown in **Figure 20** and **Figure 21**.

Figure 20 - Single Nozzle Placement (0-75" Perimeter Duct)

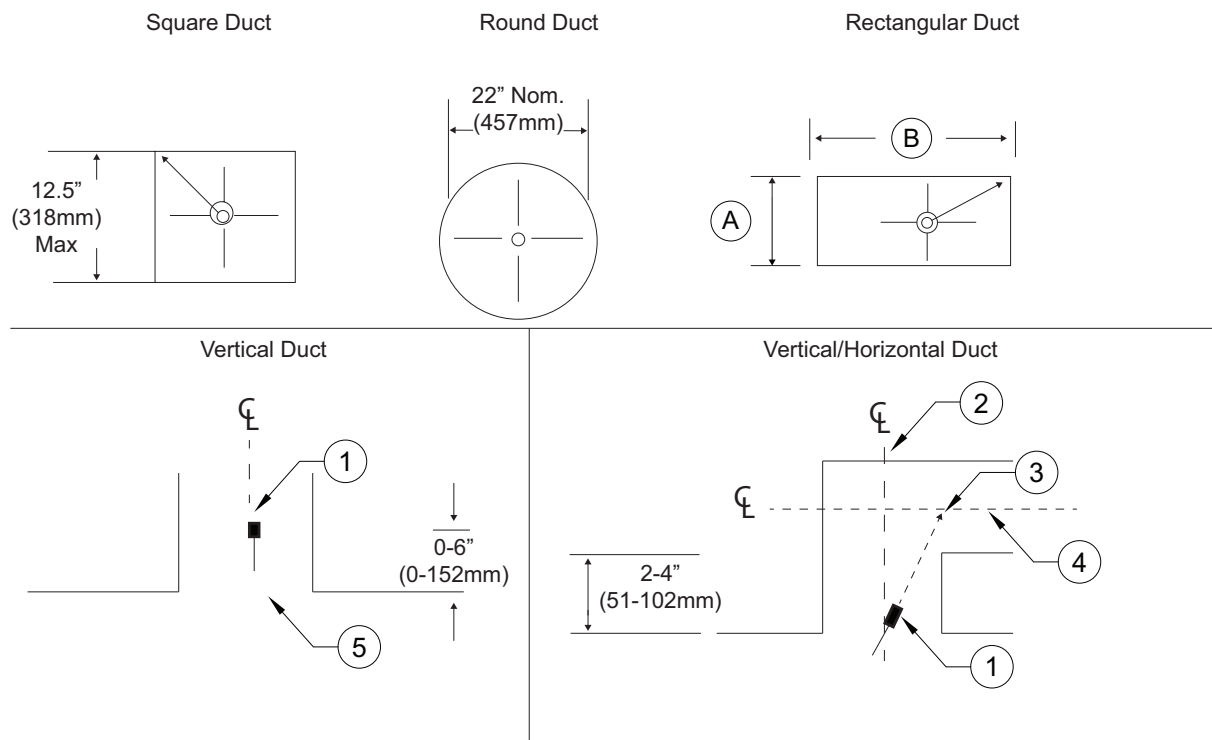

1. Nozzle
2. Horizontal Duct Centerline (CL)
3. Aim Point
4. Vertical Duct Centerline (CL)
5. Duct Entrance

- A. Rectangular Duct Width
- B. Rectangular Duct Length

- Duct perimeter up to and including 75" (1270mm).
- To determine the perimeter: $2(A) + 2(B) = 75"$ (1905 mm).

Figure 21 - Dual Nozzle Placement (75-150" Perimeter Duct)

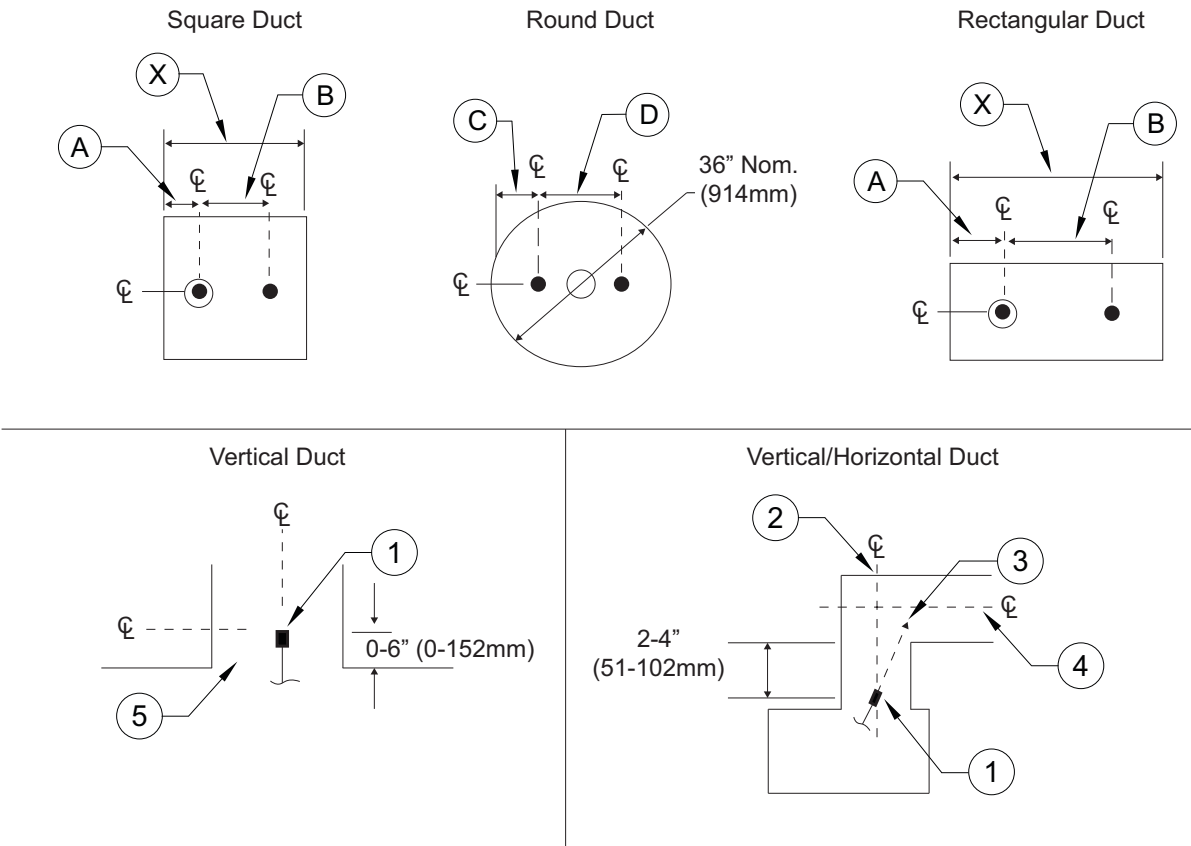

1. Nozzle
2. Vertical Duct Centerline (CL)
3. Aim Point
4. Horizontal Duct Centerline (CL)
5. Duct Entrance

- A. 1/4 of dimension X
- B. 1/2 of dimension X
- C. 1/4 of Duct Diameter
- D. 1/2 of Duct Diameter

Ventilation Exhaust and Dampers

The TANK Fire Suppression extinguishing system can be used with the exhaust fan either on or off when the system is discharged. It is recommended that the exhaust fan remain on at the time of discharge to aid in the removal of smoke, gases, and other airborne materials from the hazard area in the event of a fire. If the Authority Having Jurisdiction (AHJ) requires that the damper closes in the event of a fire system discharge, the system designer shall provide for protection downstream of the damper in compliance with NFPA 96, local codes, and/or as approved by the AHJ.

Electrostatic Precipitators (ESP)

An Electrostatic Precipitator (ESP) is designed to remove smoke and other airborne contaminants from the air flowing through the exhaust ductwork as a means of pollution control. Exhaust ductwork using ESPs requires Overlapping Male nozzle(s) (p/n OL-M [previously 3070-3/8HH-10-SS]) upstream, before the ESP. Distribution piping to the nozzles must not interfere with the function of the ESP unit.

A Pollution Control Unit (PCU) and/or Electrostatic Precipitator (ESP) covered with this fire system can utilize up to 12 nozzles per tank.

Appliance Protection

The TANK Fire Suppression system utilizes both overlapping and dedicated nozzle appliance coverage, depending on the type of cooking appliance(s) requiring protection. The Hazard Zone consists of the cooking surface of each appliance underneath each hood. For dedicated and overlapping nozzle information, refer to **“Nozzles” on page 8**.

Overlapping appliance coverage allows a given area under the hood, defined as the hazard zone, to be protected by overlapping nozzles. Nozzles are evenly spaced at the same height and alignment (front-to-back) relative to the hazard zone.

Dedicated appliance protection utilizes a nozzle, or nozzles, for protection of an individual appliance.

Overlapping, dedicated appliance, plenum, and duct protection may be incorporated in a single pipe network on the TANK Fire Suppression extinguishing system, as long as the number of nozzles per tank does not exceed five.

The following sections detail the different nozzle coverage and placement parameters for overlapping and dedicated nozzle appliance protection methodologies. Double row coverage is allowed for TANK.

Overlapping Appliance Protection

A single hazard zone utilizing overlapping coverage is 30” deep, by the total length of the hazard zone for the protected appliances. The cooking surface of all appliances protected by overlapping nozzles must be located within the defined hazard zone area. Cooking appliances eligible for overlapping protection are outlined in **Table 3 on page 20**. The lowest and highest cooking surface will determine the height of the fire suppression nozzles. All overlapping nozzles must be mounted at the same height in a single hazard zone.

For applications where overlapping protection cannot be used, such as an upright boiler, dedicated appliance protection must be used.

Figure 22 - Overlapping Protection Option

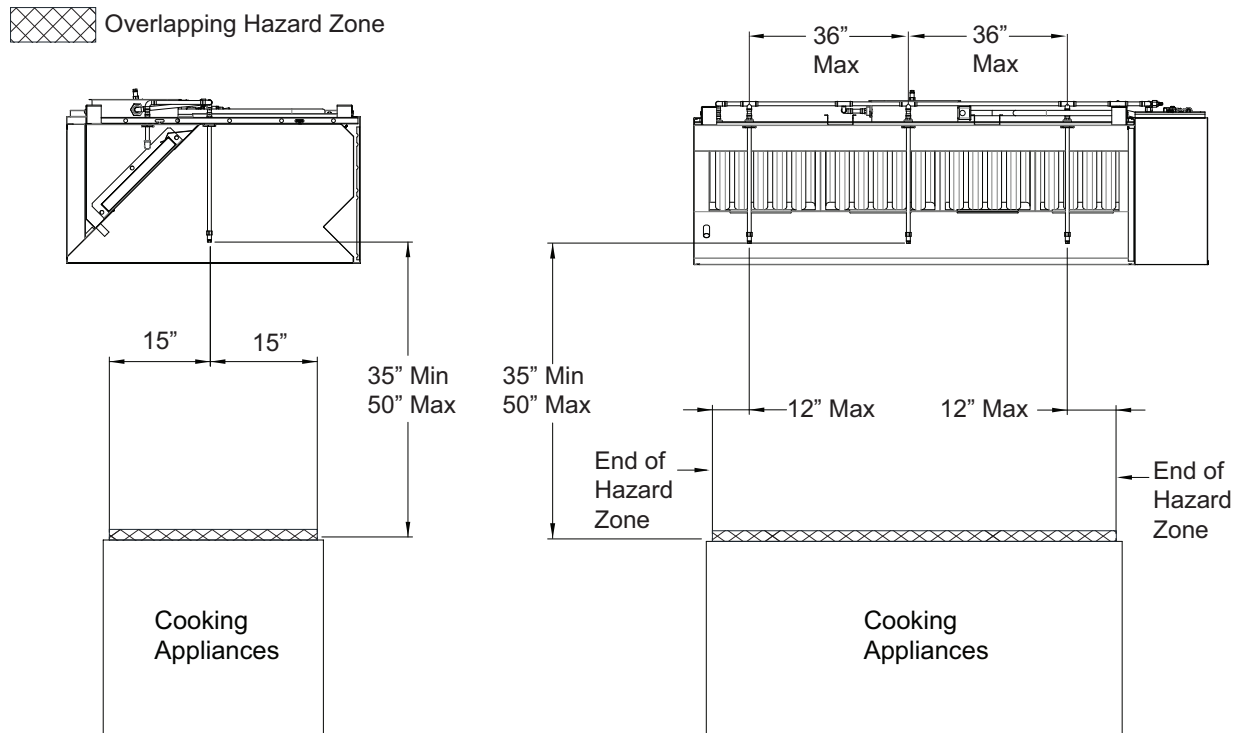

Appliance Coverage

Table 3 illustrates the maximum permitted hazard zone dimensions of each appliance that can be protected within a single overlapping zone. It is important to note that the hazard zone (area requiring protection) is different than the total appliance size.

**Table 3 - Standard Overlapping Protection 5 nozzles per tank (20 flow points),
36" max nozzle spacing**

Hazard	Fuel Source	Maximum Depth of Hazard Zone	Maximum Length of Hazard Zone	Maximum Height of Fuel
Multi Vat Fryer ⁽³⁾ ⁽⁸⁾ (with or without Drip-board)	Gas or Electric	30" deep	Unlimited	N/A
Split Vat Fryer ⁽³⁾ ⁽⁸⁾ (with or without Drip-board)	Gas or Electric	30" deep	Unlimited	N/A
Tilt Skillet ⁽⁸⁾ ⁽⁴⁾	Gas or Electric	30" deep	Unlimited	N/A
Griddle	Gas or Electric	30" deep	Unlimited	N/A
Gas/Electric Radiant Charbroiler	Gas or Electric	30" deep	Unlimited	N/A
Upright Charbroiler/ Salamander, Chain*	Gas or Electric	30" deep	Unlimited	N/A
Appliance without Shelf/Obstruction*	Gas or Electric	30" deep	Unlimited	N/A
Range without Shelf/Obstruction*	Gas or Electric	30" deep	Unlimited	N/A
Wok	Gas or Electric	11-24" diameter	11-24" diameter	6-3/4" deep

Notes:

1. All dimensions shown are based on overlapping protection.
2. All dimensions and areas shown reference the hazard zone of the appliance, which is typically smaller than the outside dimensions of the appliance itself.
3. For multi-vat fryers, no single fryer module (vat & drip board) can exceed the above limitations. Nozzle height(s) for fryers should be taken from the fryer's maximum level indicator.
4. Protection for tilt skillets and braising pans are to be based on the coverage parameters provided for fryer protection. Tilt skillets should be placed at the back of the hazard zone. Tilt skillet coverage must not interfere with the edge of the nozzle discharge pattern.
5. All appliance hazard surfaces must be located within the hazard zone.
6. Smaller appliances can be positioned anywhere in the zone (e.g., moved left, right, forward, or backward, provided the cooking hazard does not extend beyond the perimeter of the zone).
7. When the depth of the appliance exceeds maximum cooking hazard dimensions, a second row of nozzle coverage should be added.
8. Deep Fat/Industrial Fryer/Tilt Skillets over 14" wide and up to 34" max depth will be overlapping with 4 nozzles per tank, 30" max spacing. Max oil capacity: 24.75 gallons. Refer to **Table 4 on page 21**.

Figure 22 illustrates the placement of nozzles for TANK Fire Suppression overlapping protection.

Appliances denoted with an (*), or if there is an obstruction as defined on **Table 6 on page 21**, dedicated coverage will be required. Refer to **page 24**, **page 25**, and **page 29** for details.

Coverage Exceptions

Table 4 - Overlapping Protection 4 nozzles per tank (20 flow points), 30" max nozzle spacing

Hazard	Fuel Source	Maximum Depth of Hazard Zones	Maximum Length of Hazard Zones	Maximum Height of Fuel
Deep Fat/Industrial Fryers (with or w/o Drip-board)	Gas or Electric	34" deep	Unlimited	N/A
Pressure Fryers*	Gas or Electric	34" deep	Unlimited	N/A
Tilt Skillet	Gas or Electric	34" deep	Unlimited	N/A
Wok	Gas or Electric	Greater than 24", up to 30" diameter	30 inch diameter	9-1/2" deep

Deep Fat, Industrial, Pressure Fryers, and Skillets over 14" wide and up to 34" max depth will be overlapping with 4 nozzles per tank, 30" max spacing. Max oil capacity: 24.75 gallons.

Nozzle height(s) for fryers should be taken from the fryer's maximum level indicator.

* Henny Penny fryer models 690, 691, 692, and PXE-100 are allowed with standard 30" max nozzle spacing as long as the nozzle flow pattern is not obstructed by the lid while in the fully open position. A nozzle is required on both sides of the lid.

Table 5 - Appliances using 3 nozzles per tank, 24" max nozzle spacing

Hazard	Fuel Source	Maximum Depth of Hazard Zones	Maximum Length of Hazard Zones	Maximum Height of Fuel
Natural Charcoal Broiler	Charcoal	30" deep	Unlimited	4"
Solid Fuel Charbroiler	Mesquite or Hardwood	30" deep	Unlimited	6"
Lava Rock Charbroiler	Gas or Electric	30" deep	Unlimited	3" Depth

Table 6 - Appliance with Back Shelf 4 nozzles per tank (20 flow points), 36" max nozzle spacing

Hazard	Fuel Source	Maximum Depth of Hazard Zones	Maximum Length of Hazard Zones	Maximum Height of Fuel
Less than 12" Back Shelf	Gas or Electric	30" deep	Unlimited	N/A
12" Back Shelf	Gas or Electric	30" deep	Unlimited	N/A

- Shelves/protrusions from appliances measuring 6" or less are not considered shelves, standard overlapping coverage applies. Refer to **Table 3 on page 20**.
- Shelves/obstructions greater than 6" and up to 12" require 4 nozzles per tank, 36" max nozzle spacing.
- Shelves exactly at 12" depth require 35" distance from nozzle tip to cooking surface. Shelves less than 12" may use nozzle distance from cooking surface of 35" to 50", every effort should be taken to minimize nozzle spray pattern obstruction with the shelf. Refer to "**Appliance Top with Shelf**" on page 25 for more information.

Overlapping Protection

Standard overlapping protection is 5 nozzles (20 flow points) at 36" max spacing. Exceptions are noted below. All overlapping nozzles must be spaced no more than 12" from each end of the appliance, and located at the centerline of the 30" hazard zone (front to back), at the same height, and aimed straight down. The nozzle height must be 35" to 50" above the appliance cooking surface, except for woks, where the height is measured 3 inches below the top rim of the wok. The nozzles must be positioned along the total hazard zone length to allow protection of each appliance in the hazard zone.

Exceptions to standard overlapping protection:

- Large/Industrial fryers over 14" wide, 4 nozzles at 30" max nozzle spacing per tank.
- Woks larger than 24 inch diameter, 4 nozzles at 30" max spacing per tank.
- Appliance with shelves, 4 nozzles at 36" max spacing per tank.
- Solid Fuel Appliances, 3 nozzles at 24" max spacing per tank.

Refer to "**Coverage Exceptions**" on **page 21** for more information.

Overlapping Coverage - Group Protection

Overlapping protection provides coverage for a continuous hazard zone, with all nozzles at consistent position (i.e., zone centerline), spacing, and height.

When there is an area within a hazard zone for which continuous overlapping coverage is not applicable, the overlapping protection zone may be ended, and a new zone started for the new group of appliances. Examples where continuous protection may be interrupted include a counter, storage or prep area, appliance not requiring protection (e.g., enclosed oven) or an appliance requiring dedicated appliance coverage.

The examples on **page 23** provide details of group overlapping protection for interrupted zones. This section illustrates the methodology for defining when a new hazard zone is required, as described above. For appliance specific overlapping coverage parameters (e.g., nozzle spacing and height requirements), refer to **page 24** through **page 31**.

NOTE: Overlapping nozzle spacing and height requirements are based on the appliances protected for each individual zone. Nozzles must always be located at the start and end of each zone, no more than 12" from the end of the hazard zone (edge of 1st/last cooking appliance surface). Refer to "Overlapping Appliance Protection" on page 19. Zones cannot overlap.

NOTE: All hazard surfaces in a zone must be within 35"-50" of the nozzles in that zone.

Group Protection Example 1 – Appliance line separated by unprotected space.

End nozzles must be located 12" or less (horizontally) from the end of the hazard zone. Standard overlapping nozzles must be spaced no further than the maximum allowed interval 36" on center. Refer to "Coverage Exceptions" on page 21 for more details on coverage exceptions.

Figure 23 - Example 1

- A. Zone 1 Overlapping Nozzle Spacing
- B. Zone 1 Overlapping Nozzle Height
- C. Zone 2 Overlapping Nozzle Spacing
- D. Zone 2 Overlapping Nozzle Height

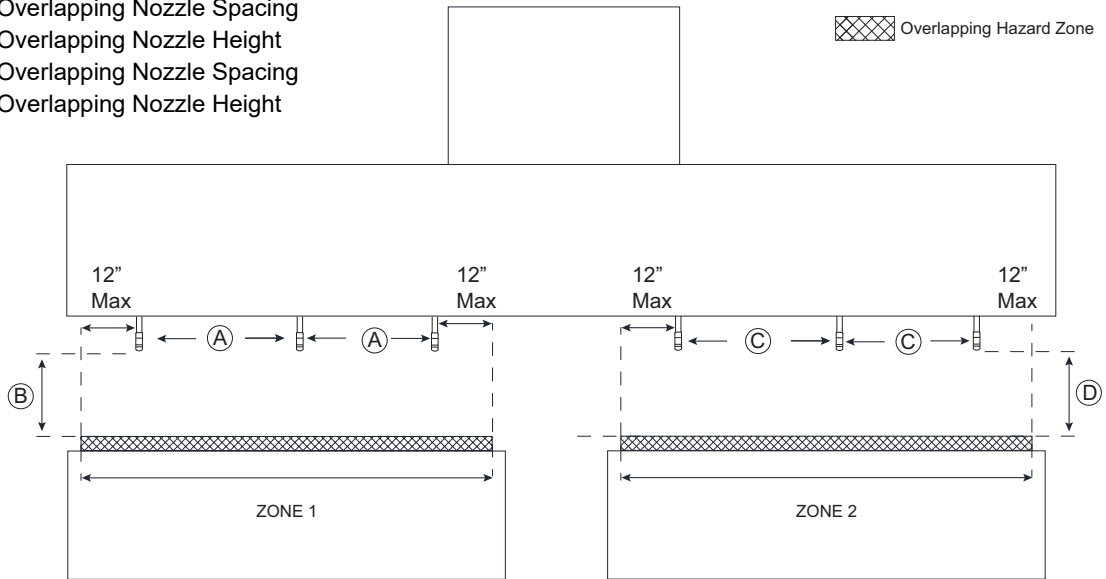

Example 2 – Appliance lines with overlapping nozzles at different heights

Figure 24 - Example 2

- A. Zone 1 Overlapping Nozzle Spacing
- B. Zone 1 Overlapping Nozzle Height
- C. Zone 2 Overlapping Nozzle Spacing
- D. Zone 2 Overlapping Nozzle Height

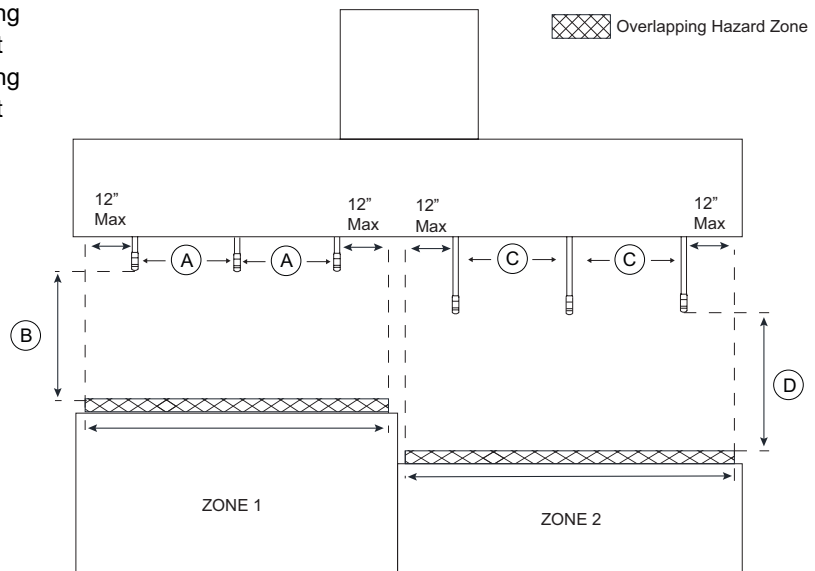

Upright Broiler/Salamander Protection

Upright broilers, chain broilers, and cheesemelters have specific coverage requirements. Unlike appliances with an exposed flat cooking surface, these appliances have an internal cooking surface and only have a small opening in the face or end of the appliance.

To cover internal hazards posed by these appliances, an Overlapping Female (OL-F) nozzle (previously 3070-3/8H-10-SS) must be placed at the opening and aimed at the opposite rear corner of the appliance. This nozzle must be branched off one of the nozzle drops and piped to the appliance opening. **No more than 2 nozzles per drop.** The drawing below illustrates how this should be accomplished. Should the cooking surface of the appliance exceed 1,050 in², an additional nozzle will be required on the opposite of the appliance for added fire protection. Refer to **Figure 25** for details.

1. Pipe and fittings above the hood will be 1/2" copper pipe/Pro-Press, Grade L copper tubing and copper Pro-Press fittings.
2. Pipe and fittings inside the hood capture volume will be 3/8" NPT stainless steel or chrome-plated black iron. No sleeving permitted.
3. Appliance coverage piping that is field piped - unions, elbows, and nozzles factory provided.
4. Install union in pipe leading to nozzle to allow for appliance removal and cleaning.
5. Nozzle heights above cooking surface (DIM A).
6. In addition to Standard Overlapping Protection, additional nozzles may be utilized for supplemental appliance specific protection. No more than two (2) nozzles may be used on a single drop.
7. Appliance drop fittings may be sealed with pipe dope or Teflon tape.

Figure 25 - Broiler/Salamander Protection

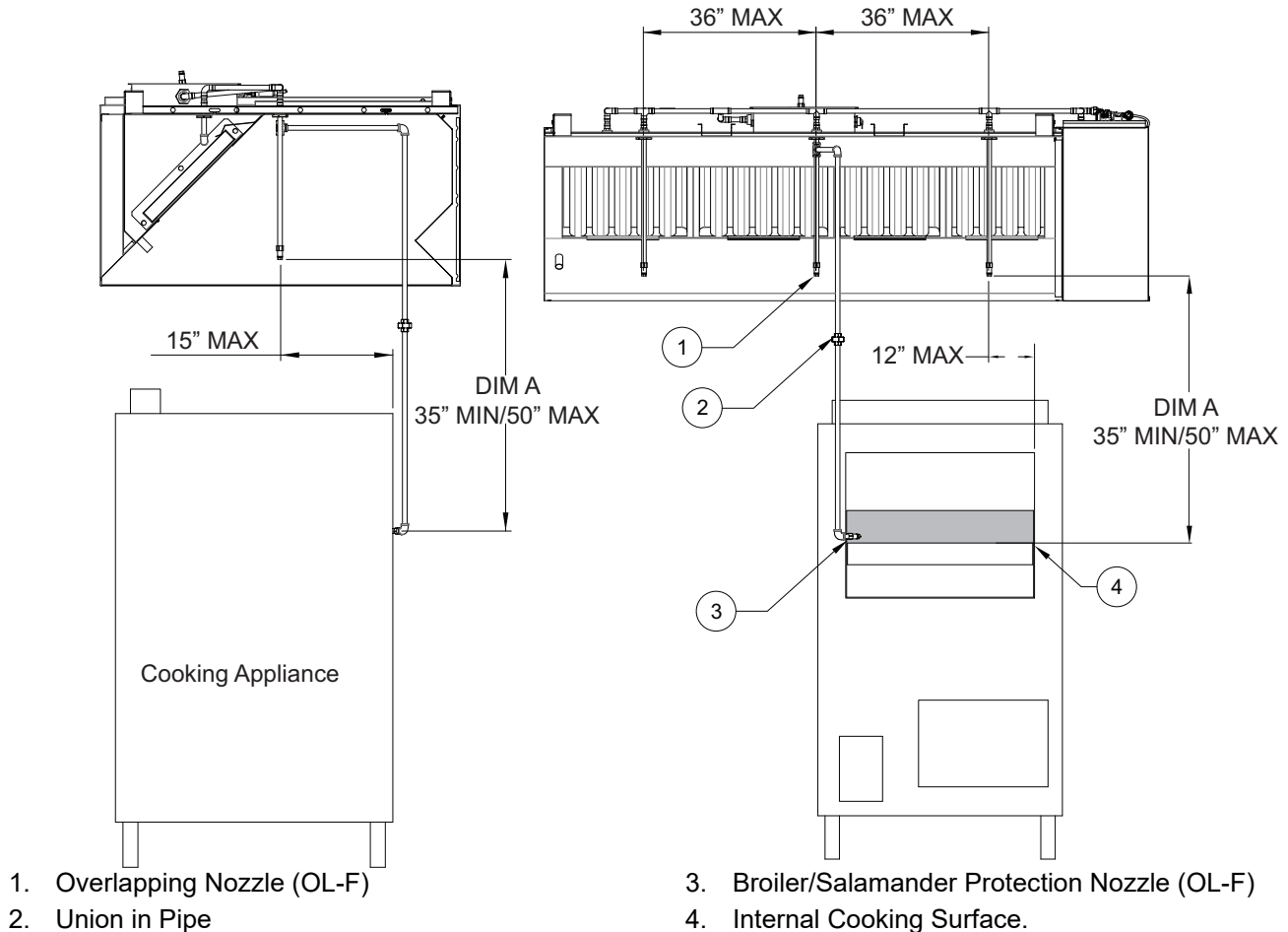

Appliance with Shelf

An Overlapping Female (OL-F) Nozzle (previously 3070-3/8H-10-SS) is used for Appliance Top Cooking equipment protection. This type of cooking equipment is available with multiple burner assemblies. Some appliances are equipped with shelving behind the appliance for additional storage. **Figure 26** illustrates the shelf cannot overhang the appliance more than 12" from the back of the cooking surface.

All dimensions fixed unless otherwise noted (e.g., min/max).

1. Pipe and fittings above the hood will be 1/2" copper pipe/Pro-Press, Grade L copper tubing/fittings.
2. Pipe and fittings inside the hood capture volume will be 3/8" NPT stainless steel or chrome-plated black iron. No sleeving permitted.
3. Appliance coverage piping that is field piped - unions, elbows, and nozzles factory provided.
4. Nozzle heights above cooking surface (DIM A).
5. Appliance drop fittings may be sealed with pipe dope or Teflon tape.
6. Shelves or protrusions from appliances measuring 6" or less are not considered shelves, standard overlapping coverage applies. Refer to "Appliance Coverage" on page 20.

Figure 26 - Appliance Top with Shelf

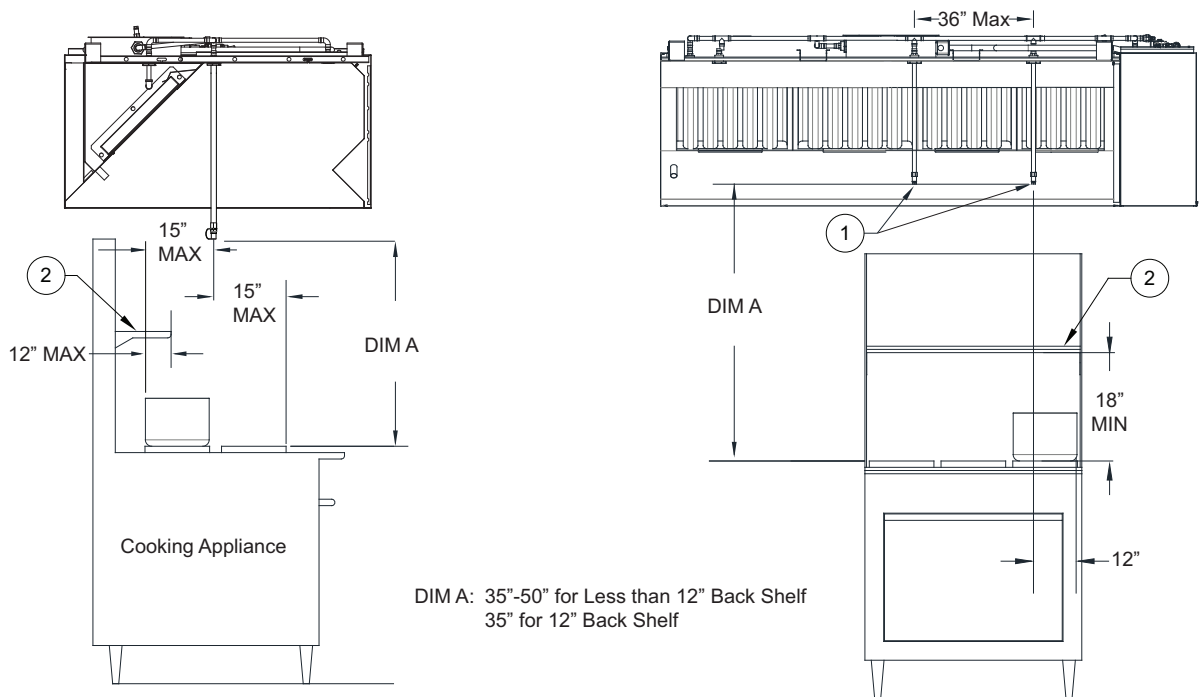

1. Overlapping Nozzle (OL-F)

2. Shelf - 12" maximum distance from the rear edge of the cooking hazard to the front edge of the shelf.

Wok Protection

An Overlapping Female (OL-F) Nozzle (previously 3070-3/8H-10-SS) is used for Wok protection. The nozzle must be located within 12" from the left or right of the Wok and 15" from the front or back of the Wok. The Wok diameter range for protection is 11" to 24" diameter.

1. Pipe and fittings above the hood will be 1/2" copper pipe/Pro-Press, Grade L copper tubing/fittings.
2. Pipe and fittings inside the hood capture volume will be 3/8" NPT stainless steel or chrome-plated black iron. No sleeving permitted.
3. Nozzle heights above cooking surface (DIM A).
4. Appliance coverage piping that is field piped - unions, elbows, and nozzles factory provided.
5. Install drops at 36" maximum spacing. Drops must be installed with an internal pipe wrench or other no-marring pipe tool.
6. Appliance drop fittings may be sealed with pipe dope or Teflon tape.

Figure 27 - Wok Diameter Protection (up to 24")

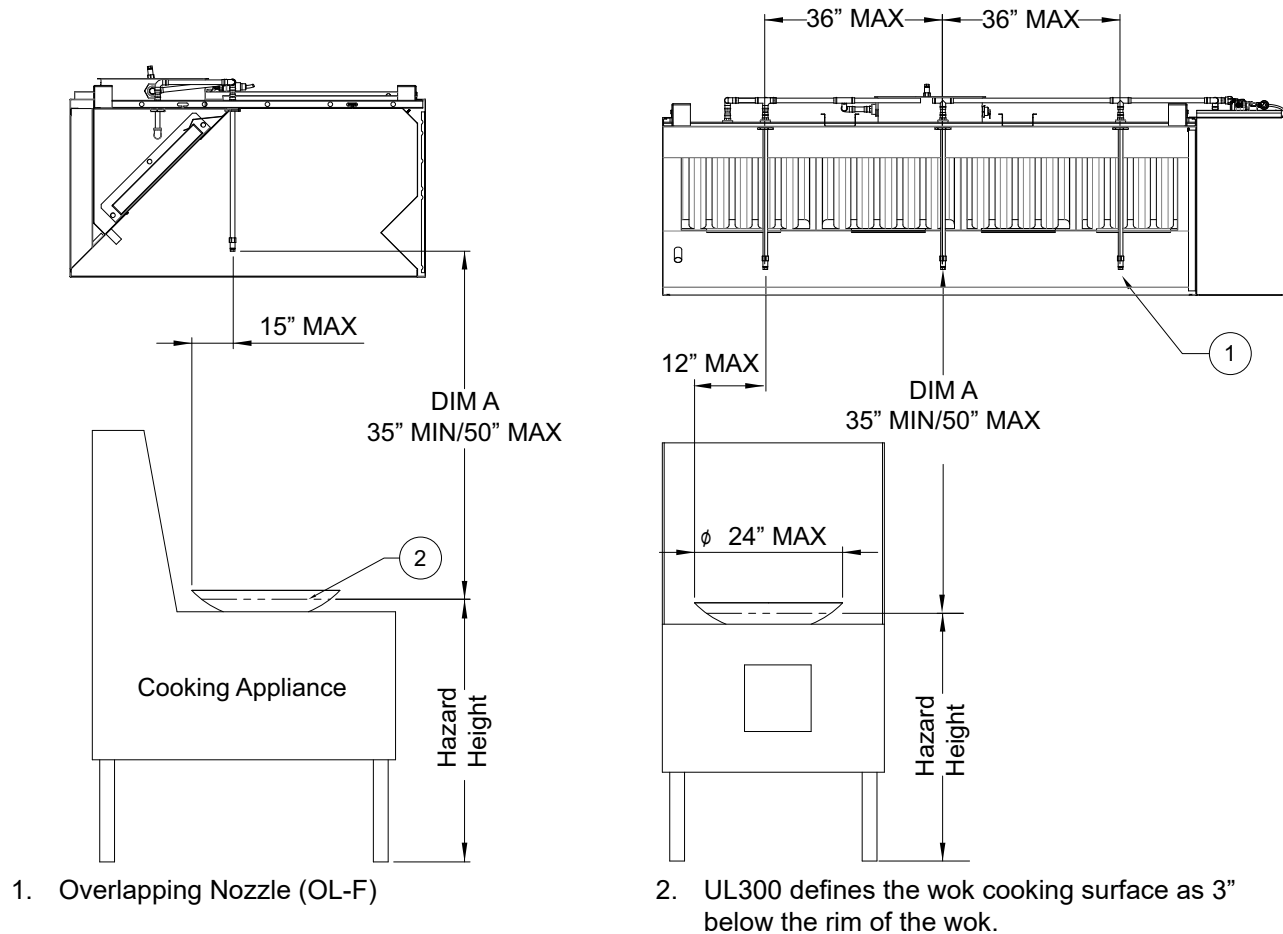

Large Wok Protection

An Overlapping Female (OL-F) Nozzle (previously 3070-3/8H-10-SS) is used for Wok protection. The nozzle must be located within 12" from the left or right of the Wok and 15" from the front or back of the Wok. The Wok diameter range for protection is 30" diameter. 4 nozzles per tank, 30" max nozzle spacing.

1. Pipe and fittings above the hood will be 1/2" copper pipe/Pro-Press, Grade L copper tubing/fittings.
2. Pipe and fittings inside the hood capture volume will be 3/8" NPT stainless steel or chrome-plated black iron. No sleeving permitted.
3. Appliance coverage piping that is field piped - unions, elbows, and nozzles factory provided.
4. Nozzle heights above cooking surface (DIM A).
5. Install drops at 30" maximum spacing. Drops must be installed with an internal pipe wrench or other no-marring pipe tool.
6. Appliance drop fittings may be sealed with pipe dope or Teflon tape.

Figure 28 - Wok Diameter Protection (up to 30")

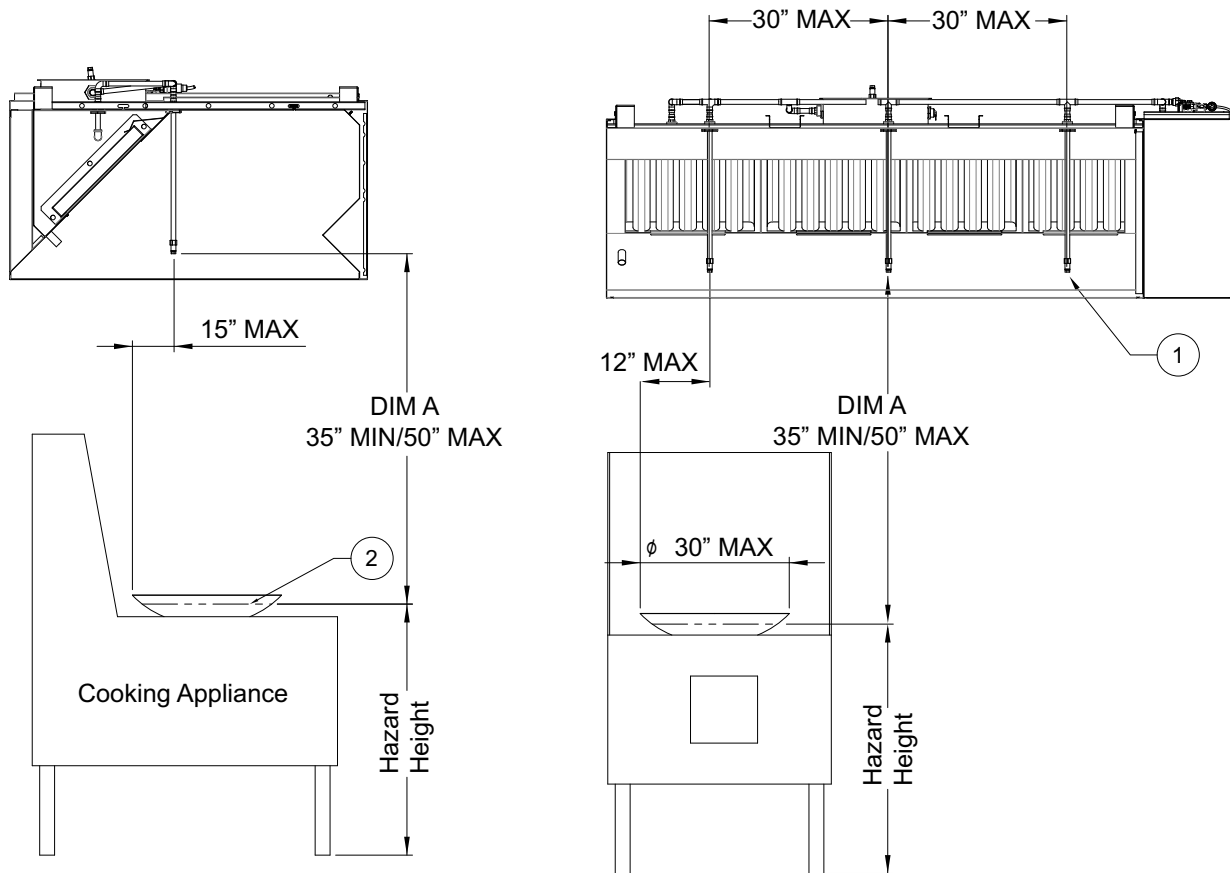

1. Overlapping Nozzle (OL-F)

2. UL300 defines the wok cooking surface as 3" below the rim of the wok.

Appliance with Upright Obstruction

Salamanders/Cheesemelters have specific coverage requirements, unlike appliances with an exposed flat cooking surface, these appliances have an internal cooking surface and only have a small opening in the face or end of the appliance.

To cover internal hazards posed by these appliances, an Overlapping Female (OL-F) nozzle (previously 3070-3/8H-10-SS), is placed at the opening and aimed at the opposite rear corner of the appliance. The nozzle may be branched off one of the nozzle drops with a tee or have a dedicated nozzle drop and piped to the appliance opening. No more than two nozzles can be utilized for a single drop. Should the cooking surface of the appliance exceed 1050 in², an additional nozzle will be required on the opposite side of the appliance for added fire protection, refer to **Figure 29**. Salamander/Cheesemelters should follow “**Upright Broiler/Salamander Protection**” on **page 24**.

Additional nozzles may be piped from nozzle drops nearest the appliance, or have a dedicated nozzle drop to cover the hazard underneath the salamander. The nozzles are aimed at the centerline of the cooking surface, a minimum of 35”-50” away (DIM A). **Overlapping coverage is required for appliance specific coverage.**

All dimensions fixed unless otherwise noted (e.g., min/max).

1. Pipe and fittings above the hood will be 1/2” copper pipe/Pro-Press, Grade L copper tubing/fittings.
2. Pipe and fittings inside the hood capture volume will be 3/8” NPT stainless steel or chrome-plated black iron. No sleeving permitted.
3. Appliance coverage piping that is field piped - unions, elbows, and nozzles factory provided.
4. Install union in pipe leading to nozzle to allow for appliance removal and cleaning.
5. In addition to Standard Overlapping Protection, additional nozzles may be utilized for supplemental appliance specific protection. No more than two (2) nozzles may be used on a single drop.
6. Appliance drop fittings may be sealed with pipe dope or Teflon tape.
7. Shelf/obstruction that extends more than 10-12” from the rear edge of the cooking hazard to the front edge of shelf/obstruction.
8. The spacing between nozzles will be either 36” or 30” maximum, based on the overlapping protection required for the appliance hazard below the obstruction.

Figure 29 - Appliance with Upright Obstruction

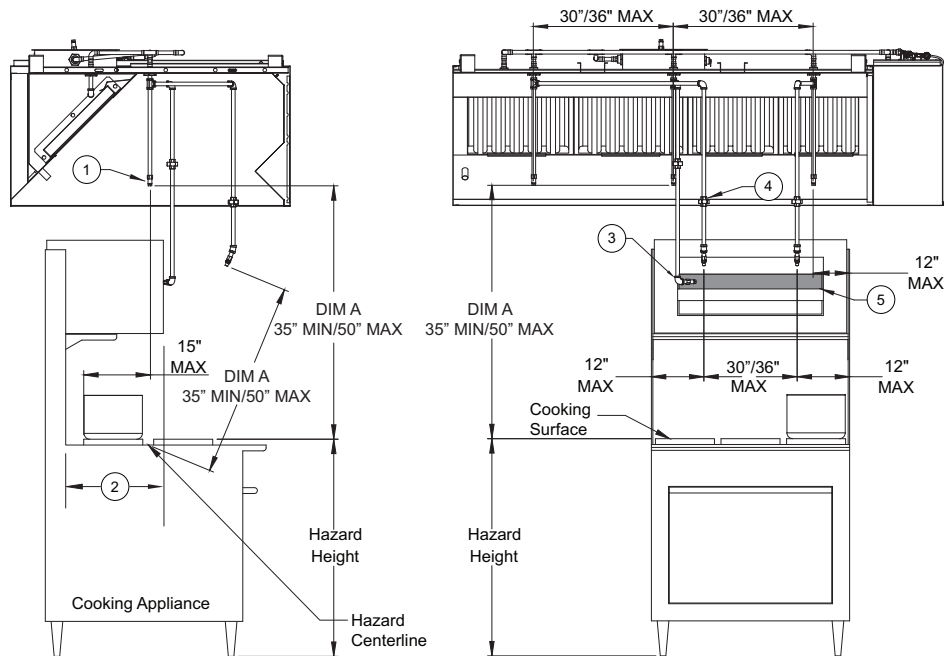

1. Overlapping Nozzle (OL-F)
2. Shelf/obstruction
3. Broiler/Salamander Protection Nozzle (OL-F)

4. Union in Pipe
5. Internal Cooking Surface

Appliance with Overhead Salamander

The following Salamander/Cheesemelter example does not require overlapping protection. Unlike appliances with an exposed flat cooking surface, these appliances have an internal cooking surface and only have a small opening in the face or end of the appliance.

To cover internal hazards posed by these appliances, an Overlapping Female (OL-F) nozzle (previously 3070-3/8H-10-SS) must be placed at the opening and aimed at the opposite rear corner of the appliance. No more than two nozzles can be utilized for a single drop. Should the appliance have an area over 1050 in², an additional nozzle will be required on the opposite side of the appliance for added fire protection, refer to **Figure 30**.

Nozzles covering Cheesemelters/Salamanders placed above an appliance can be branched off from existing overlapping nozzles or use dedicated nozzle protection. Appliance with Overhead Salamander equipment type will use dedicated nozzle protection. This nozzle is aimed at the centerline of the cooking surface, a minimum of 35"-50" away (DIM A).

All dimensions fixed unless otherwise noted (e.g., min/max).

1. Pipe and fittings above the hood will be 1/2" copper pipe/Pro-Press, Grade L copper tubing/fittings.
2. Pipe and fittings inside the hood capture volume will be 3/8" NPT stainless steel or chrome-plated black iron. No sleeving permitted.
3. Appliance coverage piping that is field piped - unions, elbows, and nozzles factory provided.
4. Install union in pipe leading to nozzle to allow for appliance removal and cleaning.
5. Additional nozzles may be utilized for supplemental appliance specific protection. No more than two (2) nozzles may be used on a single drop.
6. Appliance drop fittings may be sealed with pipe dope or Teflon tape.
7. The spacing between nozzles will be either 36" or 30" maximum, based on the overlapping protection required for the appliance hazard below the obstruction.

Figure 30 - Appliance with Overhead Salamander

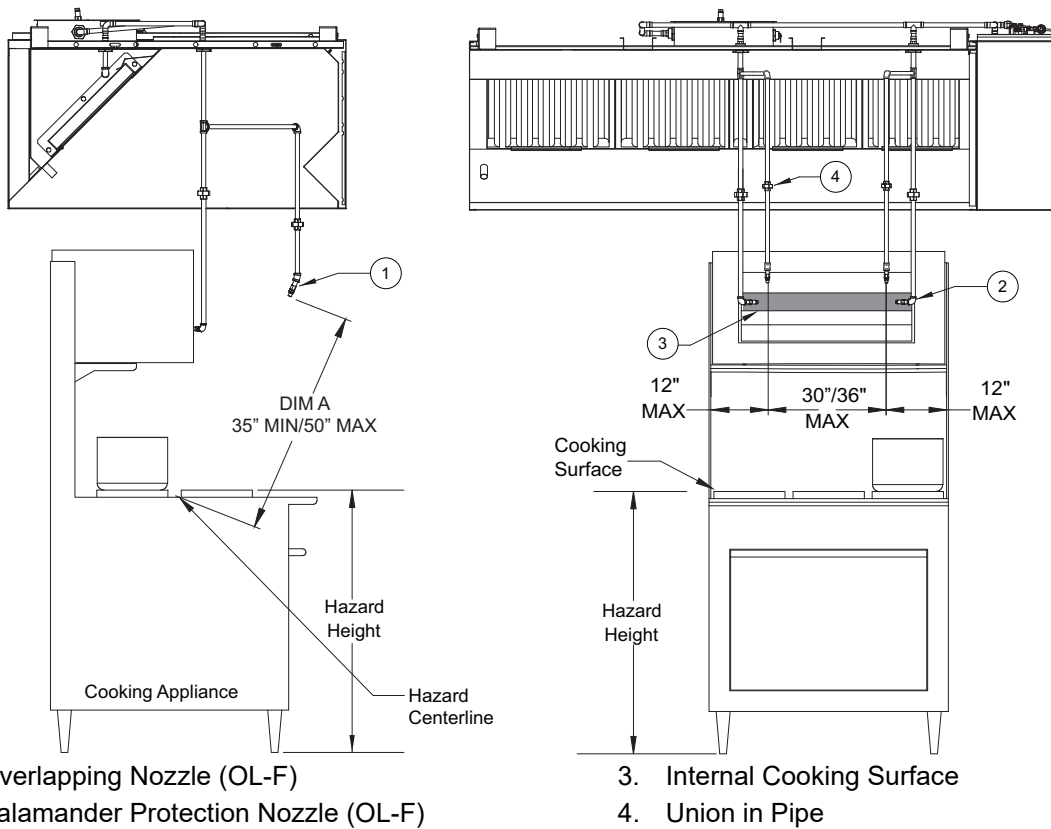

Pizza Ovens

Pizza ovens have specific coverage requirements, unlike appliances with an exposed flat cooking surface, these appliances have an internal cooking area and only have a small opening in the face or end of the appliance. When installing the appliance, make sure the nozzle does not obstruct cooking operations.

To cover the internal hazard posed by these appliances, an Overlapping Female (OL-F) nozzle (previously 3070-3/8H-10-SS) must be placed at the opening and aimed at the opposite rear corner of the appliance. No more than two nozzles can be utilized for a single drop. Refer to **Figure 31** for single stack ovens.

Figure 32 and **Figure 33** on page 31 show dual and three stack oven installation examples. Should the cooking area of the appliance exceed 1200 in², an additional nozzle will be required on the opposite side of the appliance for added fire protection. Each nozzle can cover 1200 in².

All dimensions fixed unless otherwise noted (e.g., min/max).

1. Pipe and fittings above the hood will be 1/2" copper pipe/Pro-Press, Grade L copper tubing/fittings.
2. Pipe and fittings inside the hood capture volume will be 3/8" NPT stainless steel or chrome-plated black iron. No sleeving permitted.
3. Appliance coverage piping that is field piped - unions, elbows, and nozzles factory provided.
4. No more than two (2) nozzles may be used on a single drop.
5. Appliance drop fittings may be sealed with pipe dope or Teflon tape.

Figure 31 - Single Stack Pizza Oven

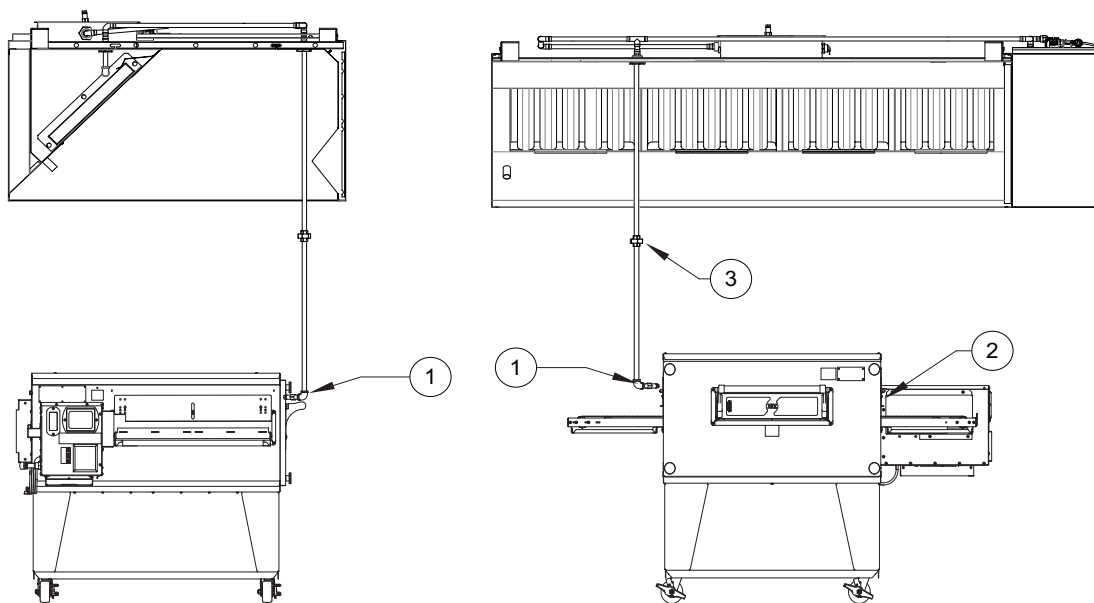

1. Overlapping Nozzle (OL-F)
2. Conveyor Opening

3. Install union in pipe leading to nozzle to allow for appliance removal and cleaning.

Figure 32 - Double Stack Pizza Oven

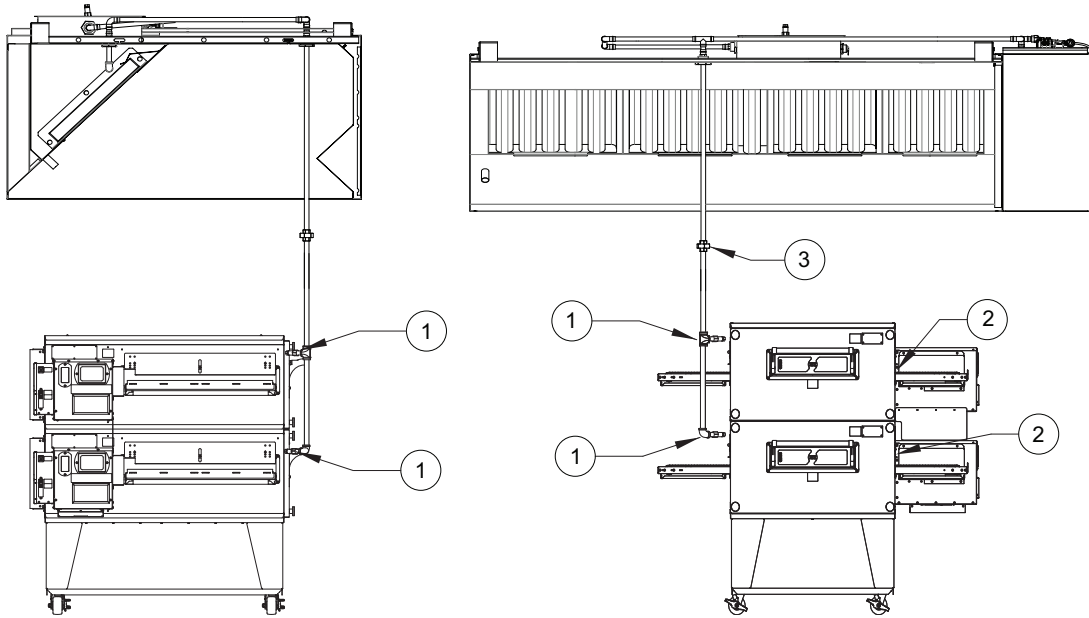

- 1. Overlapping Nozzle (OL-F)
- 2. Conveyor Opening

- 3. Install union in pipe leading to nozzle to allow for appliance removal and cleaning.

Figure 33 - Triple Stack Pizza Oven

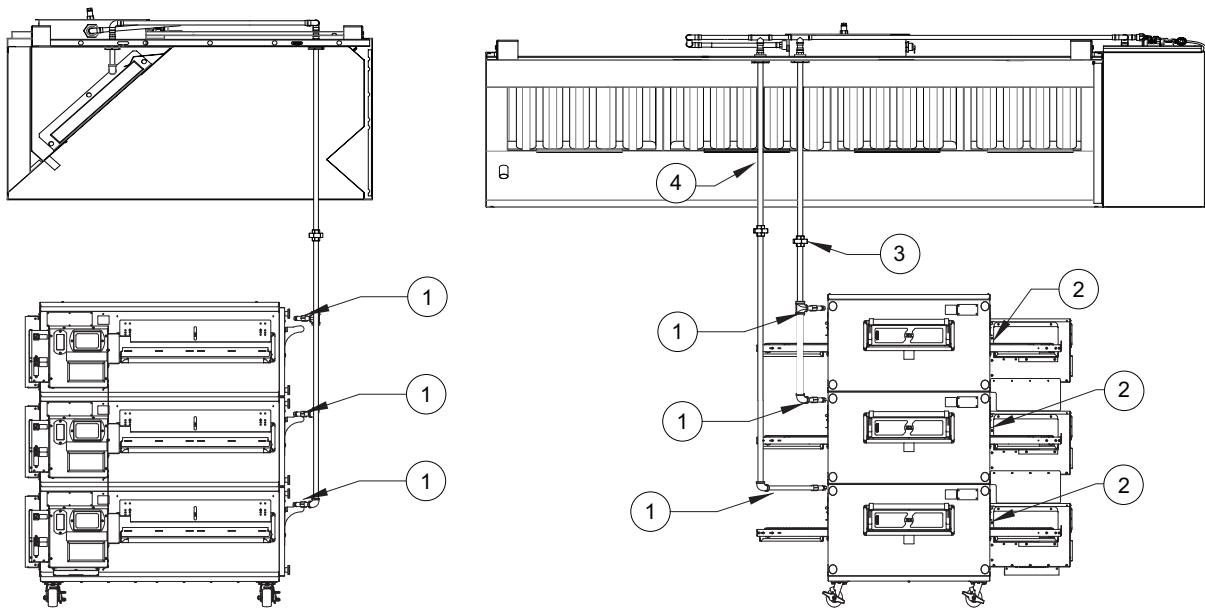

- 1. Overlapping Nozzle (OL-F)
- 2. Conveyor Opening

- 3. Install union in pipe leading to nozzle to allow for appliance removal and cleaning.
- 4. Additional drop for third nozzle. No more than two nozzles are allowed per drop.

Agent Distribution Piping

The agent distribution piping shall be 3/8" NPT Schedule 40 black iron, 3/8" NPT Schedule 40 stainless steel, or 1/2" Pro-Press copper fittings. Fittings shall be minimum class 150. Nozzle drops cannot be sleeved in steel but can be made from polished stainless steel, or polished chrome-plated black iron.

Galvanized pipe or fittings must not be used. Pipe thread or compound should be used to help seal fittings.

Distribution piping can be run in single cylinder or dual cylinder manifold configurations. Refer to **page 34** for single cylinder and dual cylinder configuration details.

The distribution network consists of a supply line and all applicable branches depending on the protected hazards. Branch lines include the plenum branch, duct branch, overlapping nozzle appliance branch, and dedicated nozzle appliance branch.

The supply line is defined as the run of all pipe and fittings from the tank outlet to the last branch line, including fittings at the start of all branch lines. All branch lines start at the outlet of the applicable supply line fitting and do not include the supply tee.

A plenum branch is defined as the run of all pipe and fittings from the supply line tee outlet to the plenum nozzle(s).

A duct branch is defined as the run of all pipe and fittings from the supply line tee outlet to the duct nozzle(s). Duct branch lines on risers greater than 75 inch perimeter can have a "tee" installed. Two separate duct branch lines are not required.

An overlapping nozzle appliance branch is defined as the run of all pipe and fittings from the supply line tee outlet to the nozzle.

A dedicated nozzle appliance branch is defined as the run of all pipe and fittings from the supply line tee outlet to the nozzle.

Refer to **page 33** and **page 34** for Supply Line, Plenum Branch, Duct Branch, Overlapping Nozzle Appliance, and Dedicated Nozzle Appliance information.

Refer to “Cylinder Nozzle and Piping Parameters” on page 34 for supply line and branch piping limitations.

Figure 34 - Distribution Piping

Hood Mounted Utility Cabinet Distribution Piping Example

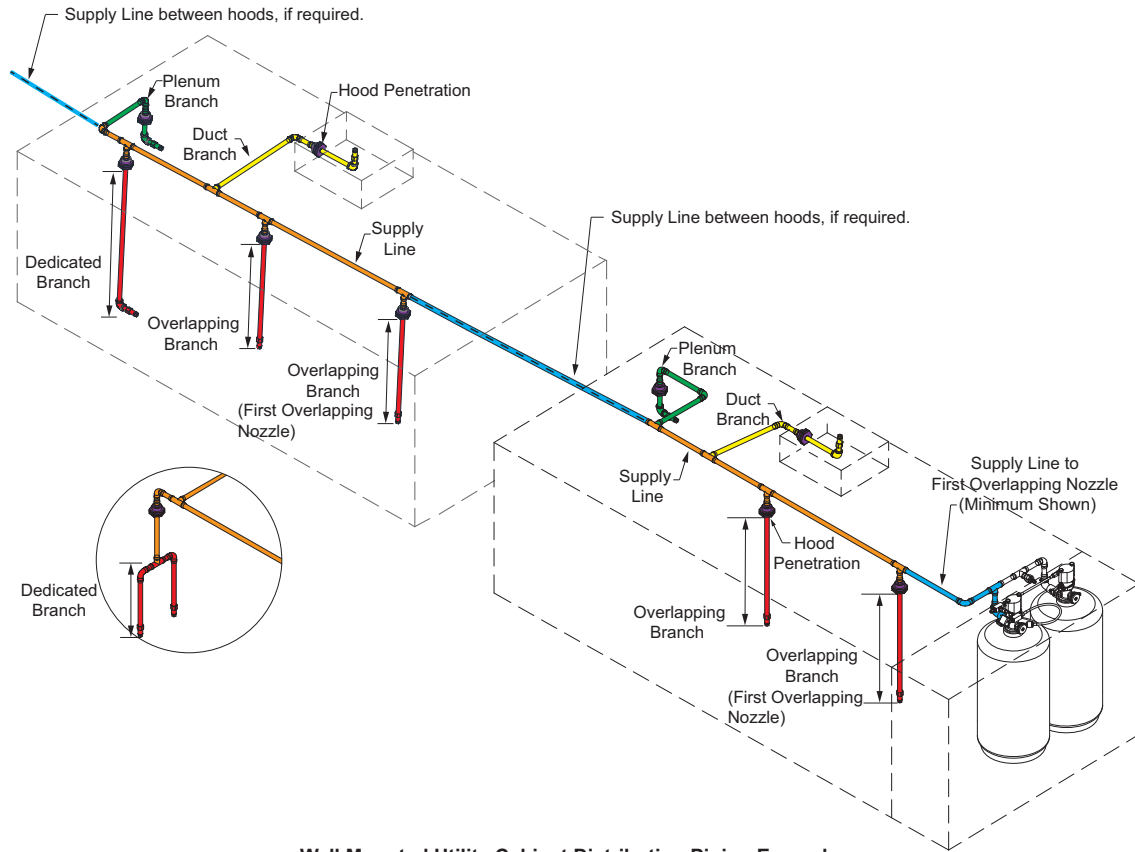

Wall Mounted Utility Cabinet Distribution Piping Example

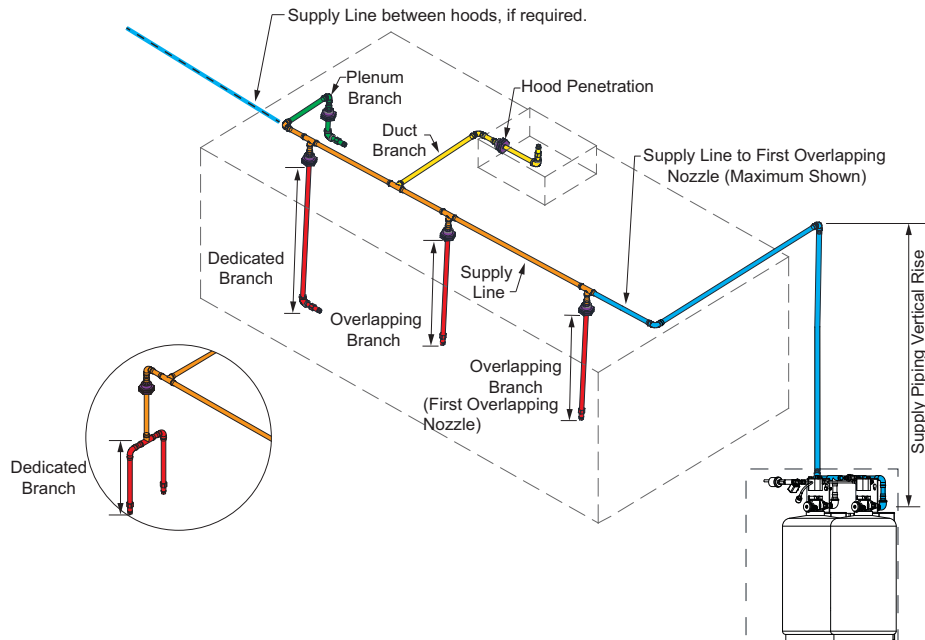

Cylinder Nozzle and Piping Parameters

A single cylinder supports up to 5 nozzles, 20 flow points. Max supply line up to 42 feet to the first overlapping nozzle.

A dual cylinder system supports up to 40 flow points and 10 nozzles. Dual cylinder systems can be piped in series or parallel. Max supply line up to 42 feet to the first overlapping nozzle.

Table 7 - Agent Distribution Piping Limitations

Pipe Section	Max Pipe Length (ft)
Max Supply Line to First Overlapping Nozzle	42
Overlapping Nozzle Appliance Branch	10
Dedicated Nozzle Appliance Branch	10

Notes:

1. One (1) tee allowed per appliance drop.
2. No more than two nozzles can be utilized for a single appliance drop.
3. Additional elbows are permitted on branch lines and horizontal supply piping, provided linear pipe length is reduced by corresponding equivalent length (1.3 ft per 90° elbow, 0.6 ft per 45° elbow).

For example: a 3/8" steel elbow has an equivalent length of 1.3 ft. An appliance branch may use 4 elbows, provided the total linear pipe is reduced by 1.3 ft (e.g., from 5 ft to 3.7 ft). Additional pipe cannot be added in lieu of fittings, as pipe volume limits could be exceeded.

4. Maximum 6 ft vertical rise of supply line above cylinder outlet.
5. Minimum 7 ft. of supply line to first overlapping nozzle.
6. If hoods are piped to the same tank, the sum of piping between hoods plus distance to first overlapping nozzle should NOT exceed 42 feet.

Nozzle Installation

Distribution piping and nozzles are factory-installed. Verify that the nozzles and distribution network are installed in accordance with the design and installation parameters for all protected hazards, as set forth in this manual.

NOTE: The TANK Fire Suppression extinguishing system design must be reviewed if any hazard changes have been made, including (but not limited to): appliance type, appliance sizes, appliance location, factory pre-piping or nozzles, plenum size or configuration, and duct size or configuration.

1. Ensure nozzles are securely installed. DO NOT OVERTIGHTEN.

NOTE: Do not over-tighten or nozzles may be damaged.

2. Ensure all nozzle types, placement, and aim are in accordance with the limitations in this manual. Nozzles can be used to achieve proper aim on dedicated appliance protection nozzles only.
3. Refer to **Figure 6 on page 8** for details on nozzle(s).

Gas Shut-Off Valves

The electric gas valve is held open in the energized state, and closes when de-energized via the output relay of the control panel. A listed manual reset relay is required to ensure manual reset prior to fuel being restored in accordance to NFPA17A.

Gas valves (**Figure 35**) are designed to shut off the flow of gas to the kitchen appliances in the event of fire system activation. Electric gas shutoff valves must be installed with an upstream strainer to prevent debris from prohibiting gas valve function. New pipe, properly reamed and cleaned of metal burrs, should be used. Proper care is needed to ensure that the gas flow is in the same direction as indicated on the gas valve and strainer. Do not over-tighten pipe connections. Apply pipe dope to the male threads only. If necessary, install a drip leg in the gas line in accordance with the Authority Having Jurisdiction (AHJ).

120V AC gas valves 3/4" - 2" can be mounted with the solenoid in any position above horizontal.

120V AC gas valves 2-1/2" - 3" must be mounted with the solenoid vertical and upright. The pipe must be horizontal.

All **24V DC** gas valves must be mounted with the solenoid vertical and upright. The pipe must be horizontal.

Proper clearance must be provided in order to service the strainers. A minimum of 4" clearance distance must be provided at the base of the strainer.

Figure 35 - Electric Gas Valve

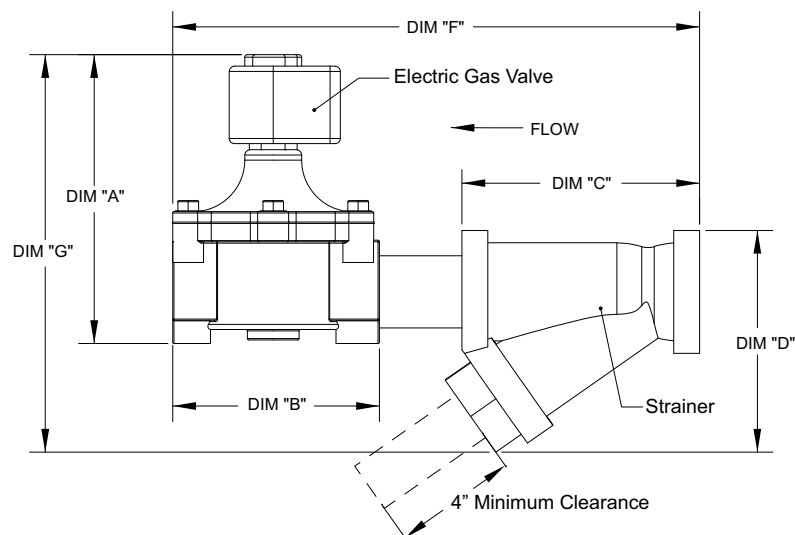
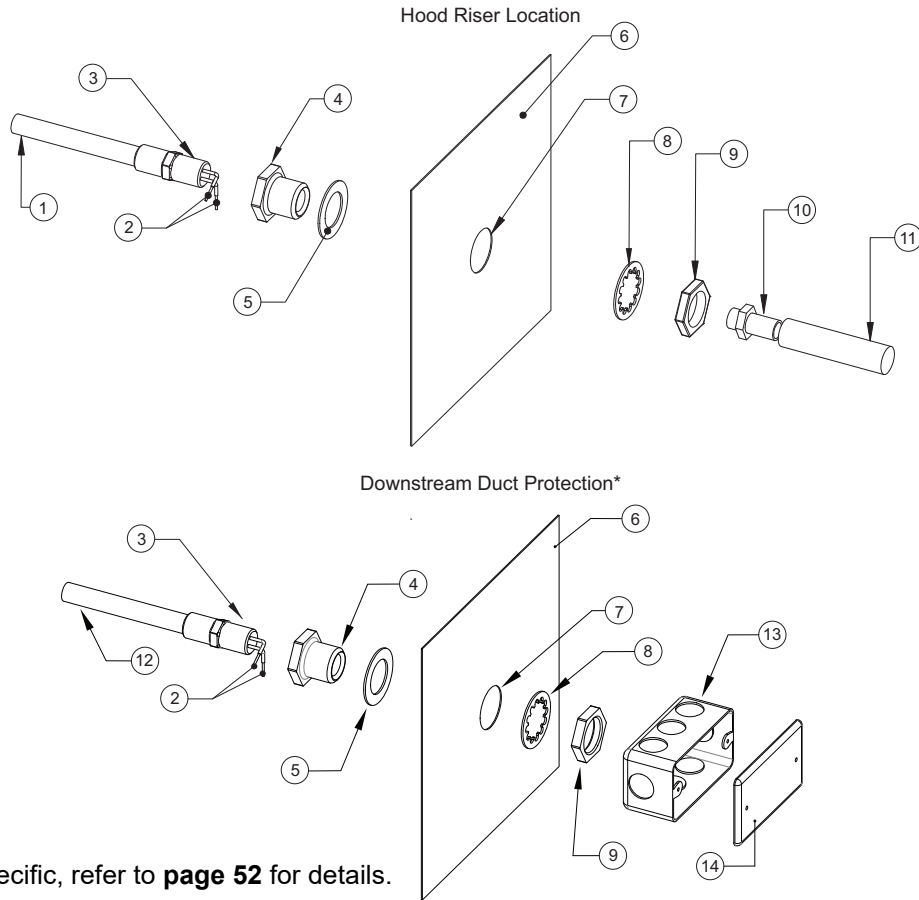

Table 8 - Gas Valve Details

Gas Valve ASCO	Size	DIM "A"	DIM "B"	DIM "C"	DIM "D"	DIM "E"	DIM "F"	DIM "G"
8214235	3/4"	6-15/16"	5-15/16"	4"	4-1/2"	11-15/16"	9-7/8"	
8214250	1"	6-15/16"	5-15/16"	4-7/8"	5-3/16"	12-13/16"	10-11/16"	
8214265	1-1/4"	7-5/8"	6-3/8"	5-1/8"	5-15/16"	13-1/2"	12-1/16"	
8214275	1-1/2"	7-5/8"	6-3/8"	5-3/4"	6-3/16"	14-1/8"	12-5/16"	
8214280	2"	7-5/8"	6-3/8"	7-1/4"	7-13/16"	15-5/8"	13-15/16"	
8214290	2-1/2"	10-5/16"	8-1/16"	8-7/8"	9-7/8"	18-15/16"	18-5/8"	
8214240	3"	10-5/16"	8-1/16"	10"	10-15/16"	20-1/16"	19-11/16"	

A gas strainer is supplied with the unit and recommended to be installed.

Figure 36 - Firestat Installation Details



* Application specific, refer to **page 52** for details.

Firestat Components

1. Hood Riser Firestat
 - Fenwal Part Number - 12-F28021-32144-OT-360 - Normally Open, Close on Rise @ 360°F
 - Fenwal Part Number - 12-H28021-12144-OT-600 - Normally Open, Close on Rise @ 600°F
2. Wiring - 2 black wires/2 white wires.
3. Seal threads with Teflon Tape before installation
4. 1/2" NPT Quick Seal (Adapter Body) - Part Number Kit 32-00002
5. 1/2" NPT Quik Seal (Gasket) - Part Number Kit 32-00002
6. External Surface of hood/duct.
7. 1 1/8" - 1 1/4" diameter hole.
8. 1/2" NPT Quik Seal (Lock Washer) - Part Number Kit 32-00002
9. 1/2" NPT Quik Seal (Nut) - Part Number Kit 32-00002
10. 1/2" flex conduit connector - Part Number A009088
11. Flex metallic conduit to ECP junction box (closest to the hood) - Part Number A0005719
12. Duct Protection Firestat
 - Fenwal Part Number 12-F28021-005360 - Normally Open, Close on Rise @ 360°F
 - Fenwal Part Number 12-H28021-005-OT-600 - Normally Open, Close on Rise @ 600°F
13. Extension Ring - Part Number 59361-1/2
14. Extension Ring Cover - Part Number 100-BW

Hood Riser Sensor Replacement

The following instructions are for replacing a hood duct stat or fire stat located in the riser.

NOTE: Make sure the fire system is deactivated and all controls are powered down before servicing the unit. Service should only be performed by trained personnel.

1. Locate faulty sensor in hood riser. Remove the hood filters to access from the hood plenum.
2. Determine the location of the sensor's lead ends. This will either be on the top of the hood, in the junction box which has conduit routed to the riser, or in the electrical control package that is mounted on the hood (if it is a stand-alone hood).
3. Access the sensor's lead ends and remove Wago connectors. Attach a fish tape (or pulling rope) to the lead ends.
4. Unscrew the sensor from the quick seal in hood plenum. Pull leads completely out, pulling the fish tape until exposed.
5. Attach replacement sensor to fish tape and pull back through conduit until lead ends are back in the original location.
6. Replace Wago connectors on the new sensor's lead ends.
7. Twist new sensor counterclockwise, 2-1/2 turns to pre-tension wires. Thread sensor in riser quick seal (using Teflon tape on threads).
8. Replace hood filters.
9. Power up the system to test functionality.

Figure 37 - Sensor Replacement

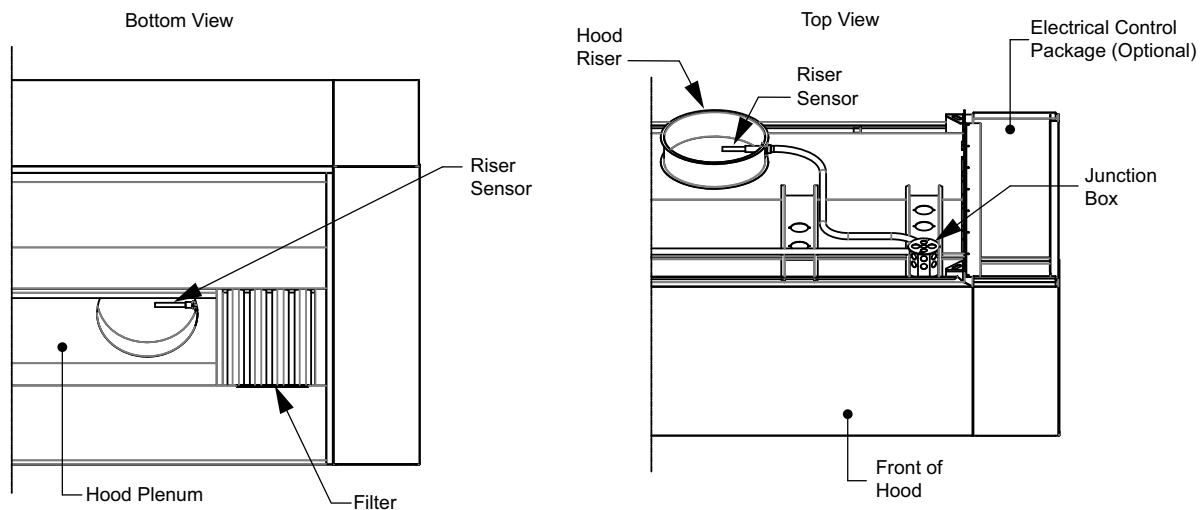

Fire Protection Manual Actuation Device

The push/pull station (**Figure 38**) is a remote manual actuation device to activate the fire system. This remote manual actuation device (push/pull station) contains one set of normally open contacts and mounts to any standard single gang junction box. When the front button is pressed, the electrical connection to the fire system is completed, thus activating the fire system.

The remote manual actuation device (push/pull station) should be mounted at a point of egress and positioned at a height determined by the Authority Having Jurisdiction (AHJ). This position is usually 10 to 20 feet from hood and 42 to 48 inches above the floor. Multiple remote manual actuation devices (push/pull stations) are acceptable to use in the fire system and are wired in parallel per the electrical schematic. The remote manual actuation device (push/pull station) is reset by twisting the push-button clockwise until the internal latch is released.

The clear protective cover must be installed to protect the device from accidental activations. This cover is provided as part of the manual actuation device. Refer to **Table 9** for device part numbers and replacement parts.

NOTE: When connecting the wires to the push/pull station, do not twist the wire ends together. Insert each wire on the opposite side of the screw.

Figure 38 - Manual Activation Device

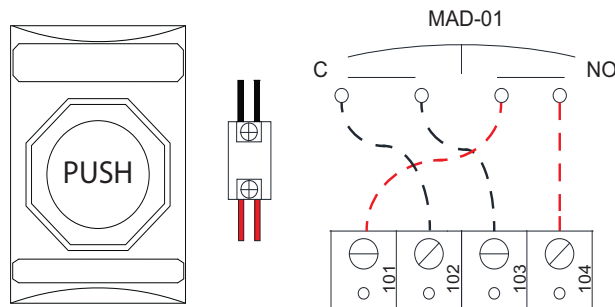

Table 9 - Activation Device Part Numbers

Part Description	Part Number
Push-Button with Clear Cover	SS2031ZA-EN
Push-Button with Clear Cover and Horn	SS2041ZA-EN
Red Junction Box with Deep Back for Surface Mount	STI-KIT71101AR
Normally Open Contact	STI-10196
Contact Housing Assembly	SF-10197H

Trouble Input Wiring

Trouble contacts and supervision switches from each device may be connected to the optional trouble input of the building fire alarm panel to indicate a trouble condition.

Figure 39 - Optional Wiring Connection for Trouble Contact

1. Building Fire Alarm
2. CORE Control Panel Trouble Contact
3. End of Line Device
4. Building Fire Alarm - Trouble Input Wiring

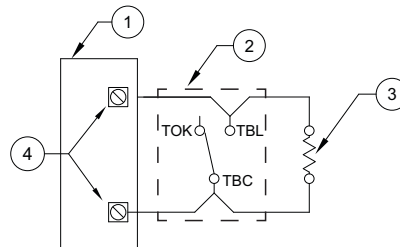

Fire Protection System Printed Circuit Board

The fire protection system printed circuit board (PCBCORE) is a microprocessor-based controller that provides all the necessary monitoring, timing, and supervision functions required for the reliable operation of the fire system.

Under normal conditions, the “Fire System Activated” light is on. This indicates the system is armed and active. If a fault is detected anywhere in the system, an audible alarm will periodically sound, and the “Fire System Activated” light will flash a fault code to indicate the fault that was detected. The HMI, located on the hood or Electrical Control Package (ECP), will display the fault text to explain where the issue is located in the system. Refer to **“CORE Board Faults” on page 54.**

NOTE: CORE Boards with software version 1.68 and prior will use one brief flash every 3-seconds to indicate there are no faults in the fire system.

When viewing the CORE Board, if a series of flashes followed by a pause exists, there is a fault in the system. Count the number of flashes between the pauses and refer to **“CORE Board Faults” on page 54.** Any fault is extremely important and must be corrected and rectified immediately to ensure proper operation of the fire system.

The optional connections for building fire panels are located at AL1 and AL2 as dry contacts.

For remote mounted Ansul Automans, use terminals AU1 and AU2. This will provide a dry contact connection point to provide power for activating the Ansul Automan.

NOTE: When a CORE board is connected to an ECPM03 board, if a fire condition happens, the “Last Fire Info” will be stored on the ECPM03 screen. “Last Fire Info” will be available on CASLINK as well.

Figure 40 - Printed Circuit Board

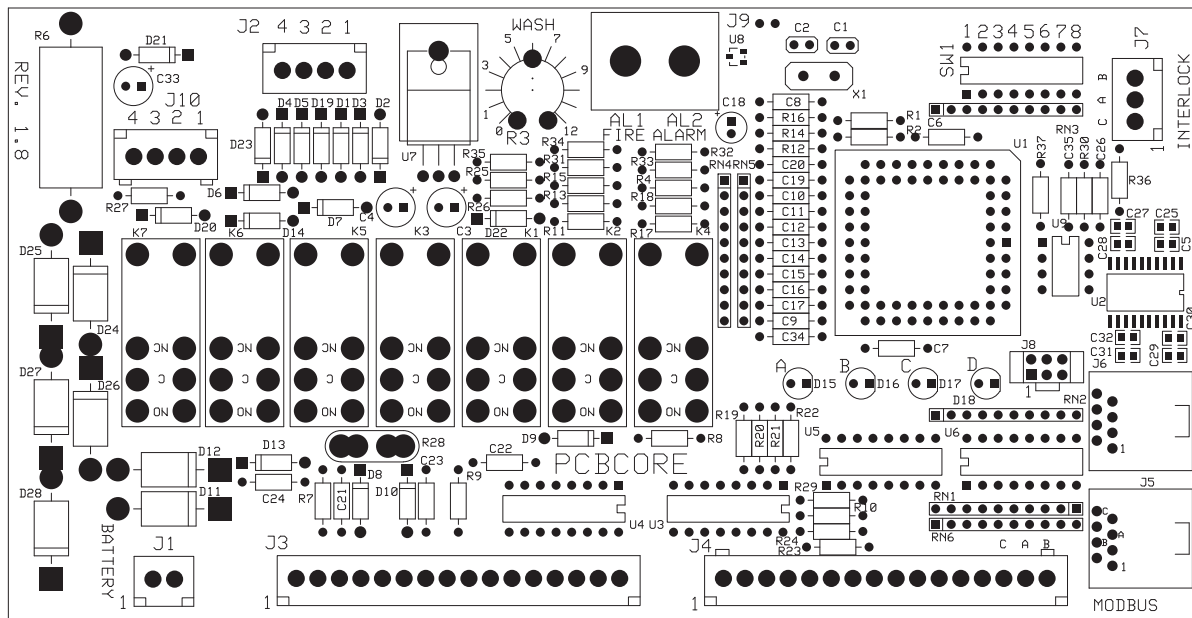

Connector Descriptions

Note: Some connections may not be used dependent on system configurations.

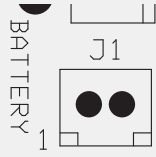
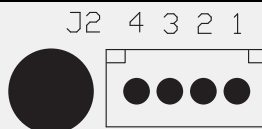
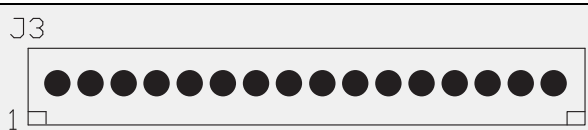
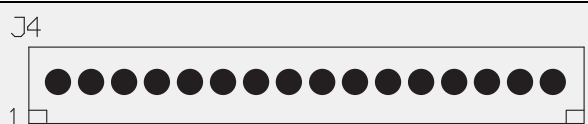
<p>Connector J1 contains battery pack connections for battery charging and monitoring.</p>	
<p>Pin 1 – Battery Positive</p>	<p>Pin 2 – Battery Negative</p>
<p>Connector J2 contains Supervised Sensor Loop connections</p>	
<p>Pin 1 – Start Positive Loop Pin 2 – Start Negative Loop</p>	<p>Pin 3 – Finish Negative Loop Pin 4 – Finish Positive Loop</p>
<p>Connector J3 contains Power Supply and Device connections</p>	
<p>Pin 1 and Pin 2 – Positive Input, Power Supply Pin 3 and Pin 4 – Negative Input, Power Supply Pin 5 – Positive Output, Gas Valve Solenoid Pin 6 – Positive Output, Surfactant Pump Pin 7 – Positive Output, Release Valve Solenoid Pin 8 and Pin 9 – 24V DC Input, Shutoff Valve Supervision</p>	<p>Pin 10 – N/A Pin 11 – Drive Output, Fire Relay Pin 12 – Drive Output, 100% Relay Pin 13 – Drive Output, Trouble Relay Pin 14 – Drive Output, Wash Relay Pin 15 – Drive Output, Spare Relay Pin 16 – Drive Output, Auto-Man Relay</p>
<p>Connector J4 contains Power Supply and Device connections</p>	
<p>Pin 1 – Positive Input, Power Supply Pin 2 – Output, Panel Mounted Audible Alarm Pin 3 – Output, Panel Mounted LED Fire/Fault Indicator Pin 4 – N/A Pin 5 – Drive Output, Cooking Equipment Disable Relay Pin 6 – Negative Input, Power Supply Pin 7 – N/A</p>	<p>Pin 8 – Input, Pump Prime/Reset Push Button Pin 9 – Input, Gas Cartridge/Pressure Switch Pin 10 – Input, Fan Switch Pin 11 – Input, Gas Valve Reset Push Button Pin 12 – Input, Door/Tamper Switch Pin 13 – Input, Test Mode Pin 14 – Modbus Network, Common Signal (C) Pin 15 – Modbus Network, Negative Signal (A) Pin 16 – Modbus Network, Positive Signal (B)</p>

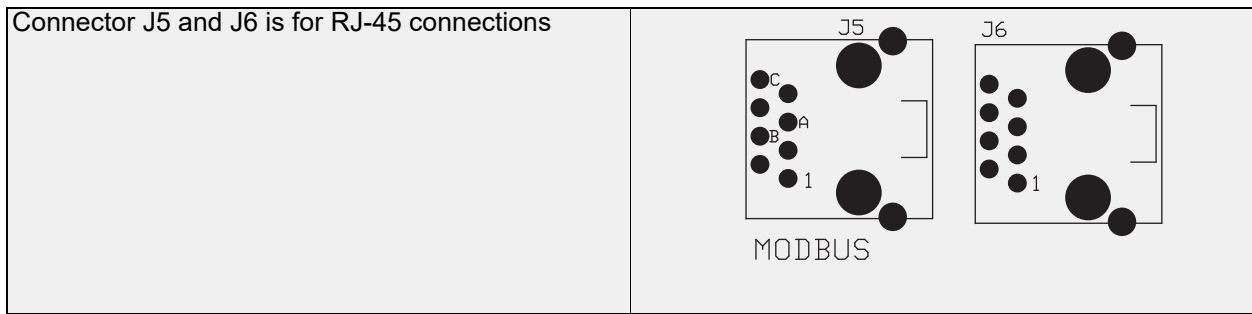

These two connections are for the Modbus Network. This network may be used by non-fire system related equipment to monitor operating conditions of the electrical (PCBCORE) board.

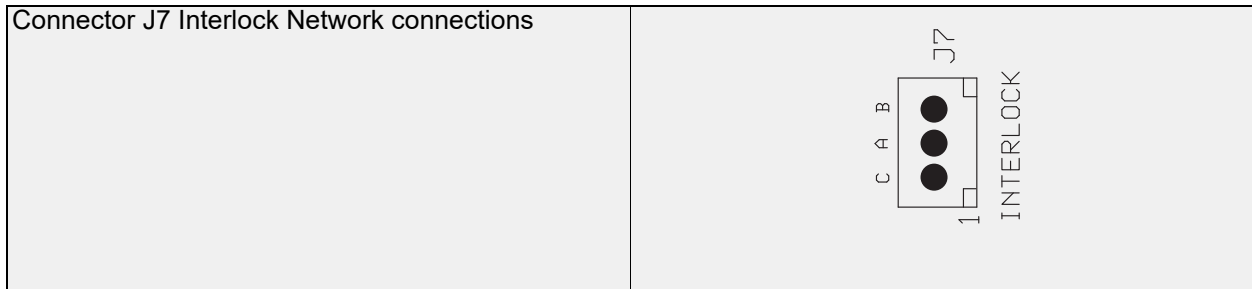

Pin 1 – Interlock Network, Common Signal (C) Pin 2 – Interlock Network, Negative Signal (A)	Pin 3 – Interlock Network, Positive Signal (B)
--	--

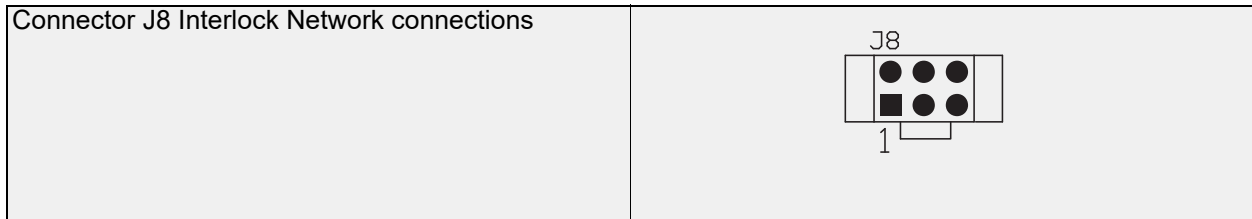

Factory Use Only

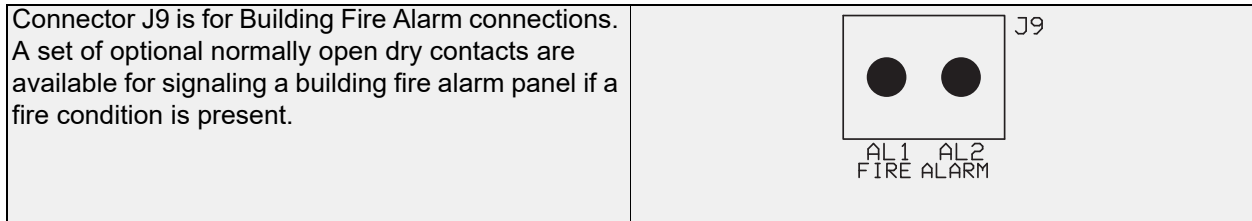

Pin 1 – Dry Contact Closure	Pin 2 – Dry Contact Closure
-----------------------------	-----------------------------

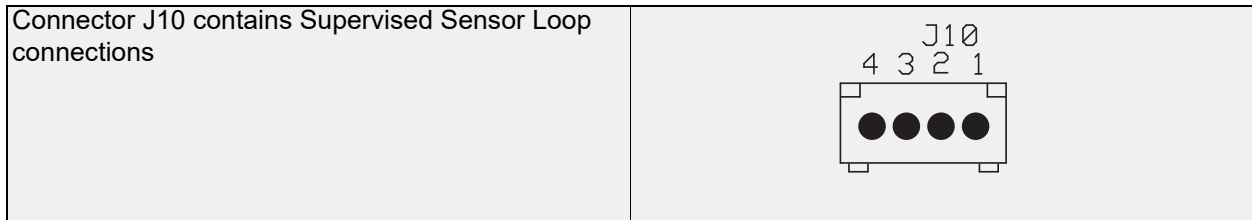

Pin 1 – Start Positive Loop Pin 2 – Start Negative Loop	Pin 3 – Finish Negative Loop Pin 4 – Finish Positive Loop
--	--

Electrical

WARNING!

Disconnect power before installing or servicing control. High voltage electrical input is needed for this equipment. A qualified electrician should perform this work.

Before connecting power to the control package, read and understand the entire section of this document. As-built wiring diagrams are furnished with each control package from the factory and are either attached to the door of the unit or provided with the paperwork packet.

Electrical wiring and connections must be made in accordance with local ordinances and the National Electric Code, ANSI/NFPA70. Verify the voltage and phase of the power supply, and the wire amperage capacity is in accordance with the unit's nameplate.

ATTENTION: LOW-VOLTAGE DC OR SIGNALING WIRE SHOULD BE ROUTED IN SEPARATE CONDUIT FROM ALL AC VOLTAGE SOURCES.

1. Always **disconnect power** before working on or near this equipment. Lock and tag the disconnect switch or breaker to prevent accidental power-up.
2. **There are multiple electrical connections** required for this control. **120V AC** should be wired to terminals **H1** and **N1**. If the hood is equipped with a separate light circuit, **120V AC** should power this circuit per the as-built schematic. **H1** and **N1** should not be connected to a shunt trip breaker.
3. Verify that the power source is compatible with the requirements of your equipment. The system wiring schematic identifies the **proper phase and voltage** of the equipment.
4. Before connecting the control package to a power source, verify power source wiring is de-energized.
5. Secure the power cable to prevent contact with sharp objects.
6. Do not kink power cable and never allow the cable to come in contact with oil, grease, hot surfaces, or chemicals. Solenoid cables **must not** come in contact with hood surfaces.
7. **The supervised loop must be run through metallic conduit.** Do not run wiring with high voltage wires. Verify all supervised loop wires are free from damage/stress. All supervised loop wires must be terminated in terminal blocks, junction boxes, and push-stations.
8. If the system contains additional firestats, they must be wired into the supervised loop.
9. If the control package is a **wall-mount system**, a duct mounted temperature sensor will need to be wired. The temperature sensor must be wired to terminal blocks, as indicated on the wiring schematic.
10. If the control package is a **wall-mount system**, the hood lights wiring will need to be wired to terminals "B" and "W." Verify connections on wiring schematic.
11. Before powering up the system, make sure that the interior of the control package is free of loose debris or shipping materials.
12. If any original internal wire supplied with the system must be replaced, use type THHN wire or equivalent.
13. All field-supplied wire for the optional fire system release solenoid or firestat must be high temp wire rated for **842°F** minimum (#441601C6.FE9 White and #441601C6.FE0 Black).
14. The battery must be plugged in at connector J1 on the electrical board (PCBCORE) after wiring is complete.
15. All gas appliances under the hood must shut down in the event of an AC power loss. All electric appliances will shut down on building power loss.
16. Use Belden #6320UL, 18 Gauge, plenum-rated wire or similar, for the supervised loop that does not come in contact with the hood. Use Belden #88760 or similar for the fire system interlock network and CAT-5 for Modbus communications.
17. All exterior wiring connections to the PCU must be run inside liquid tight conduit. This includes the supervised loop and airflow switch wiring.

IMPORTANT!: The battery backup for the fire protection system produces output power even when main power is disconnected from system. When performing major electrical service to the control, the battery backup must be disconnected then reconnected before commissioning.

Wire Ampacity Rating

The load current rating and the over-current protection for conductor types shall not exceed 15 amperes for 14 AWG, 20 amperes for 12 AWG, and 30 amperes for 10 AWG aluminum and copper-clad aluminum after any correction factors for ambient temperature and number of conductors have been applied. Refer to **Table 10**.

Table 10 - Copper Wire Ampacity @ 75°C

Wire Size AWG	Maximum Amps
14	15
12	20
10	30
8	50
6	65
4	85

Distance Limitations

Wiring connections to remote fire protection system(s) must use shielded twisted pair wire. The maximum length of this connection is 1000 feet.

Wire size is an important consideration when making the connections between the fire protection system control package and a gas valve. Refer to **Table 11** for maximum wiring distance between the system and remote gas valve.

Table 11 - Wiring Maximum Distance

Wire Gauge	Distance (Feet)
12	1049
14	660
16	414
18	260
20	164
22	103
24	64

Fire Alarm Contacts

The fire protection system is equipped with optional normally open contacts (terminals **AL1** and **AL2**) for building applications that connect to the premise Fire Alarm Control Panel (FACP). Refer to **Figure 41** for wiring reference. During a fire condition, the contacts will close and trigger the premise FACP to initiate a general fire alarm.

Figure 41 - Fire Alarm Reference

1. Building Fire Alarm
2. Control Panel Fire Alarm Contact
3. End of Line Device
4. Alarm Input

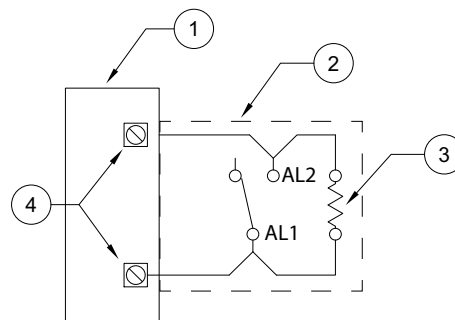

Fire Group

Fire Groups are for the purpose of using multiple CORE controlled fire systems and grouping specific fire systems together. This will allow the user the ability to assign different zones for independent activation.

In order to set a fire group, you will need to set the CORE board DIP switches as shown in **Table 12**.

Table 12 - Fire Group DIP Switch Position

6	7	Fire Group Number
Off	Off	1
On	Off	2
Off	On	3
On	On	4

Note: Every panel with matching fire group settings (DIP switches 6 and 7) will activate simultaneously in a fire condition.

Figure 42 shows an example of different zones on separate fire groups, but still connected via the interlock network. In the example, when 2 Fire groups (01 and 02) are assigned on the CORE boards, and if a fire condition exists in any one group, it will NOT activate the other fire group. However, both are connected to the same interlock network.

- Fire Group 01 CORE board DIP switch setting will be set to: Switch 6 Off and Switch 7 Off.
- Fire Group 02 CORE board DIP switch setting will be set to: Switch 6 On and Switch 7 Off.

Refer to “**Typical DIP Switch Arrangement**” on page 58 for setting multiple CORE controlled fire systems.

Figure 42 - Fire Group Reference

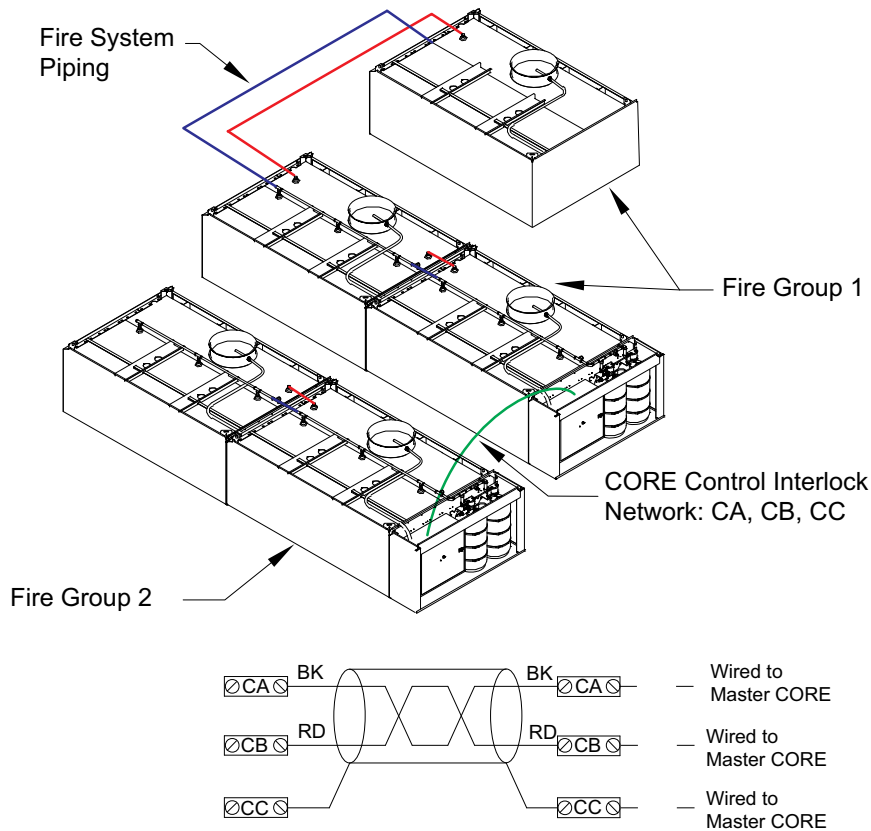

Fire Protection System Supervised Loops

The supervised loops are integral to proper operation and activation of the Fire Protection System. All systems have two supervised loops; each loop consists of two conductors, one positive and one negative. One loop is dedicated to all sensors, while the other is dedicated to all manual actuation devices (push/pull stations). The supervised loop connections are located at the front edge of the hoods for accessibility. Connections beyond the hood, like the connections at the manual actuation device, must be made with a plenum-rated wire. It is recommended to use a two-conductor Belden 6320UL, 18 AWG, wire, or similar for these connections. Refer to **Figure 43** for supervised loop details.

The supervised loop must be run through metallic conduit. Do not run wiring with high voltage wires. Verify all supervised loop wires are free from damage/stress. All supervised loop wires must be terminated in terminal blocks, junction boxes, and push-stations.

- Connections to the firestat will use two Wago connectors. One for an incoming loop and one for an outgoing loop.
- Flexible metallic conduit is used to route the wiring that connects the firestat to the remote loop junction box. Secure conduit to hood hat channel when possible.

Figure 43 - Supervised Loop Connections

1. Firestat
2. Conduit
3. Junction Box
4. Wago Connector

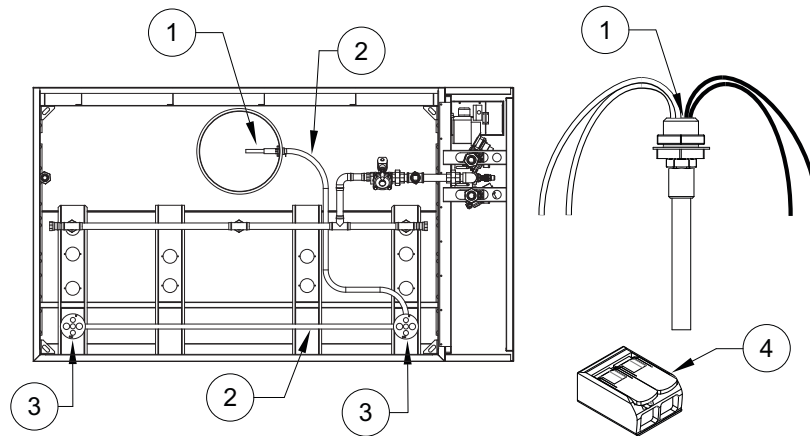

For connections on or above the hood, use Type MG or MGT wiring with Wago connectors. A Supervised Loop Connection kit is available to connect back to back or end to end hoods. This kit will come with the necessary hardware and wire.

Table 13 - Supervised Loop Components

Connection Kit Part Number	Length	Location
SLPCON-03	3 Feet	End to End Hoods
SLPCON-05	5 Feet	End to End Hoods
SLPCON-10	10 Feet	End to End and Back to Back Hoods
SLPCON-15	15 Feet	End to End and Back to Back Hoods
SLPCON-20	20 Feet	End to End and Back to Back Hoods

High Temperature Supervised Loop Components	Part Number
Type MG Wire, White, 16 AWG	441601C6.FE9
Type MG Wire, Black, 16 AWG	441601C6.FE0
Wago Connectors	221-412

Supervised Loop Electrical Details

NOTE: Place the panel in test mode when checking the supervised loop circuit.

Before checking the supervised loop circuit (**Figure 44**), verify all CORE power supplies (PS-02) are set to 27.5V +/- 0.1V DC. Check all supervised loop connections. Verify wiring is properly connected and secure. If any of the readings in **Table 14** are out of range or other faults are present, there is an issue with that loop or associated components/wiring. Refer to **page 56** for troubleshooting.

Figure 44 - Wiring for Supervised Loop

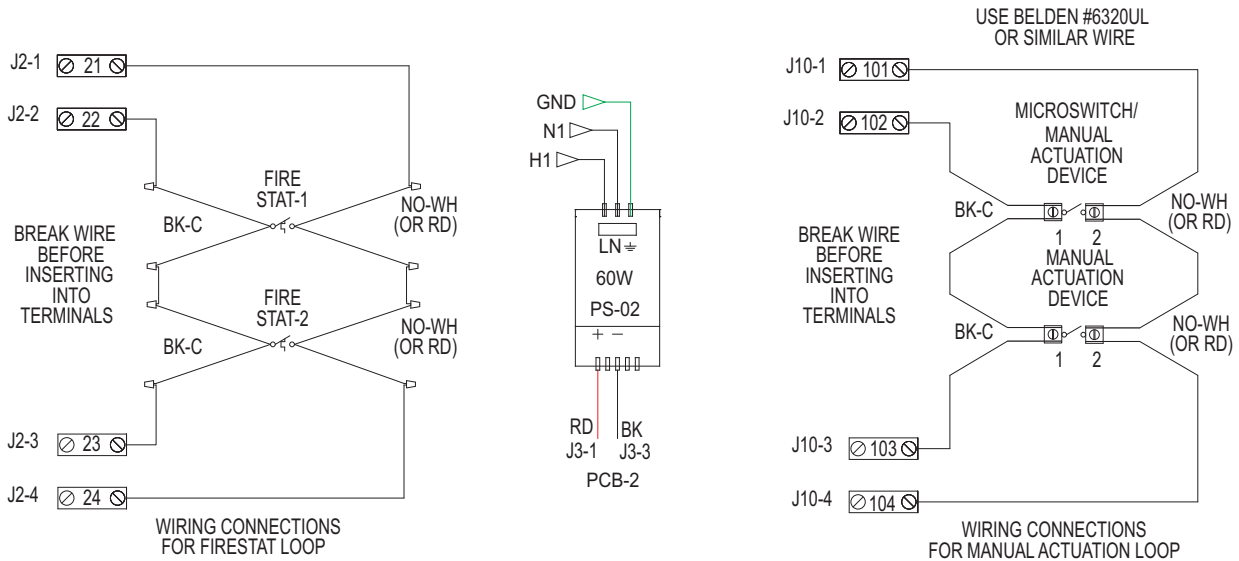

Table 14 - Supervised Loop Circuit Readings

Component Check	Procedure: Check for continuity between terminals. Place the breaker off. Disconnect the batteries at connector J1	Expected Readings
Firestat(s)	Terminals 21 and 24; Terminals 22 and 23	Continuity
	Terminals 21 and 22; Terminals 21 and 23 Terminals 24 and 23; Terminals 24 and 22	No Continuity
Manual Activation Device (MAD)	Terminals 101 and 104; 102 and 103	Continuity
	Terminals 101 and 102; Terminals 101 and 103 Terminals 104 and 103; Terminals 104 and 102	No Continuity
Component Check	Procedure: Measure voltage between terminals. Place the breaker on. Reconnect the batteries at connector J1	Expected Readings
Power Supply	PS-02 (DC+) and PS-02 (DC-)	27.5 +/- 0.1V DC
Firestat(s)	PS-02 (DC-) and Terminal 21; PS-02 (DC-) and Terminal 24 Terminal 21 and Terminal 22; Terminal 23 and Terminal 24	26.5 +/- 0.2V DC
	PS-02 (DC-) and Terminal 22; PS-02 (DC-) and Terminal 23	0 +/- 0.2V DC
	Terminal 24 and Chassis Ground	1.8 +/- 0.2V DC
Manual Activation Device (MAD)	PS-02 (DC-) and Terminal 101; PS-02 (DC-) and Terminal 104 Terminal 101 and Terminal 102; Terminal 103 and Terminal 104	26.5 +/- 0.2V DC
	PS-02 (DC-) and Terminal 102; PS-02 (DC-) and Terminal 103	0 +/- 0.2V DC
	Terminal 104 and Chassis Ground	1.8 +/- 0.2V DC

PCU Fire System

Pollution Control Units require a fire system to be installed for Type 1 applications. Current International Mechanical Code (IMC) requires that the fire system be installed by the manufacturer (2018 IMC). CORE and EWC fire systems are available for the PCU. PCU fire systems use electric sensors set at 360°F to activate the fire system. Outdoor EWC Systems require a climate controlled utility cabinet to ensure that the fire system does not drop below 32°F and does not exceed 130°F. See below for more information about outdoor installations. It is highly recommended that the PCU fire system be interlocked to the corresponding hood fire system so that if the hood system activates, the PCU system activates. Reverse activation requirements are determined by local code or at the discretion of the Authority Having Jurisdiction, but are recommended for safety.

In the event that the fire system is accidentally activated, all disposable filters must be replaced and the pre-filter cleaned. The water or chemical agent used in the fire system can cause the filters to fail prematurely.

In the event that a fire occurs in the ductwork leading to the PCU or inside the PCU, the following must be completed.

- The unit must be cleaned of all fire suppression chemicals and grease.
- The filters must be replaced, this includes the pre-filter.
- If an ESP module is present, the ESP cells must be removed, and cleaned in warm soapy water. Wash cells until all chemical residue is removed. ESP pre and post filters must be replaced. When re-installing cell(s), make sure to install with the **airflow in the correct direction** as indicated on the cell.
- If any of the gasketing is damaged, replace the gasketing between modules and between the doors.
- If any of the components that make-up the Pollution Control Unit are damaged by fire, then that component must be replaced and inspected by factory trained service personnel.

Installation, commissioning, or resetting of the fire system must be done by a licensed fire system installer. Use the guidelines set forth by the appropriate fire system manual; PCU with CORE Fire Suppression System manual, Model TANK (Electric Wet Chemical) Extinguishing System, or other fire system manufacturer.

For electric wet chemical fire systems for PCU, external piping that connects the PCU fire system nozzles to the fire system tanks is factory-installed using Grade L 1/2" copper tubing and pro-press fittings. If a remote (wall mount) EWC fire system is utilized, distribution piping shall be Grade L 1/2" copper tubing and pro-press fittings or 3/8" NPT Schedule 40 black iron, chrome-plated, or stainless-steel pipe and fittings. If distribution piping is exposed to an outdoor environment it must be Grade L 1/2" copper tubing and pro-press fittings or 3/8" NPT Schedule 40 stainless-steel pipe and fittings.

PCU Fire System Nozzles

The Overlapping Male Nozzle(s) (p/n OL-M) are used to protect the PCU.

The nozzles include a cap (p/n 3074-1-1).

Refer to **Figure 45**. The cap prevents contamination from entering the pipe network and is designed to pop-off upon system discharge, allowing the fire system to flow to the protected hazard area.

Figure 45 - Fire System Nozzle

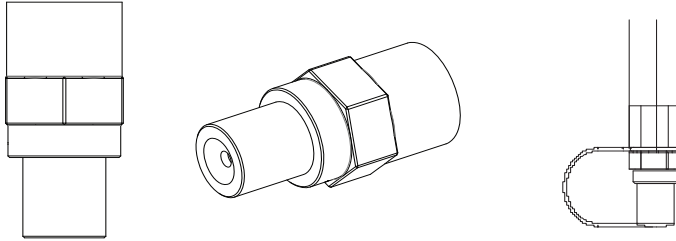

Nozzle P/N: OL-M

Previously P/N: 3070-3/8HH-10-SS

Table 15 provides details on PCU size, modules, and nozzle quantity per unit. Pollution Control Units (PCU) covered by a TANK Fire System can utilize up to 12 nozzles per tank.

PCU Fire System type "REFS" is covered by TANK.

Table 15 - PCU Fire System Chart

PCU Size	Unit Nozzle Count (OL-M)					Duct Nozzle Count (OL-M) Last Module Only
	1 Module	2 Modules	3 Modules	4 Modules	5 Modules	
1	4	8	12	16	20	2
2	4	8	12	16	20	4
3	5	10	15	20	25	4
4	6	12	18	24	30	4
5	7	14	21	28	35	4
6	7	14	21	28	35	6
7	11	22	33	44	55	6

Example:

Model - PCU-PF-HE-ESP-OC-XXXX-5
 Modules Fire System PCU Size

Number of Modules - 4

PCU Size - 5

Number of OL-M Unit Nozzles - 28

Number of OL-M Duct Nozzles - 4

Total Nozzles - 32

OPERATION

The TANK Fire Suppression extinguishing system is electrically operated via the applicable fire alarm control panel. The system can be activated automatically via an electric thermal detector or manually via a remote manual actuator. The extinguishing system is electrically operated via the PCBCORE control board. The system can be activated automatically via a Firestat or manually via a remote manual actuator. Since the TANK Fire Suppression extinguishing system is electrically operated, the applicable fire alarm control panel requires AC input power with a battery backup system. Reference the applicable control panel manual for wiring and compatibility.

When one of the system's Firestat(s) detectors senses a temperature hotter than its internal set-point (e.g., in the event of a hood fire), or when a remote manual actuation device (push/pull station) is pushed, an electric signal is sent to the tank-based fire protection release solenoid via the fire alarm control panel releasing circuit. The electric release solenoid is energized, allowing pressurization of the pneumatic actuator(s). The actuator's plunger(s) will depress into the tank valve body, releasing agent to flow to the hood duct, plenum, and appliance nozzles.

When the fire extinguishing system is activated, the applicable fire alarm control panel simultaneously shuts down all gas and electric appliances under the protected hood(s), shuts down make-up air and/or exhaust where applicable, and activates the building fire alarm where applicable.

The electrically operated fire system requires a battery backup system. In the event of a loss of building electrical power, all gas and electric appliances under the hood must be electrically interlocked to shut off. This is achieved via a gas valve relay and/or a shunt trip breaker. The battery backup will automatically energize upon a loss of power. The battery backup will monitor the fire system circuit for up to 24 hours and be able to operate the fire system circuit for a minimum of 30 minutes. Once power is restored, the battery will automatically recharge.

A means of manual reset is required for shut-off devices to ensure manual reset prior to fuel or power being restored in accordance with NFPA 17 and NFPA 96. The electric gas shut-off valve is used in conjunction with a UL/ULC listed manual reset relay, refer to **"Gas Shut-Off Valves" on page 35**.

Appliance and electrical shut down is achieved via the applicable fire alarm control panel relay, in conjunction with UL/ULC listed enclosed industrial control equipment or magnetic contactors of appropriate rating. These must be used in conjunction with a UL/ULC listed manual reset relay, refer to **Figure 46**. All wiring is to be in accordance with the applicable manufacturer's instructions for the fire alarm control panel, gas shut-off valve, manual reset relay, and contractor supplied shut-off devices. All wiring must be in accordance to NFPA 70 and the Authority Having Jurisdiction (AHJ).

The TANK Fire Suppression System is not required to be interlocked to a building's fire alarm control panel to function. When a building fire alarm system is present, the fire alarm control panel may be connected such that the actuation of the TANK Fire Suppression extinguishing system also activates the fire alarm. Reference the applicable control panel manual for wiring and compatibility.

Figure 46 - Reset Relay

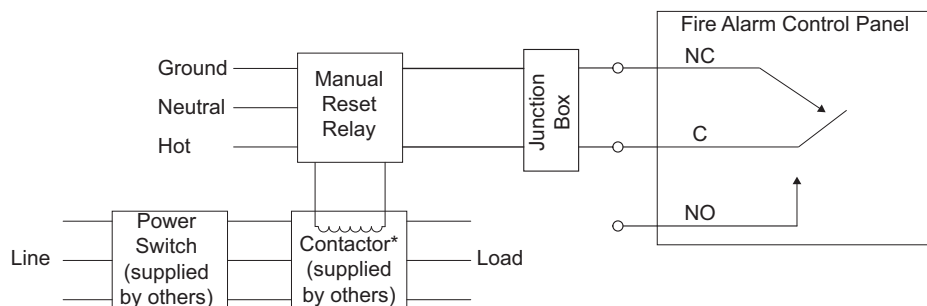

* UL/ULC listed enclosed industrial control equipment or magnetic switch of appropriate rating. Contacts closed when coil is energized.

Test Mode Overview

The fire protection system has an integrated option for testing. When in test mode, the release solenoid is disabled and will prevent the fire extinguishing agent from spraying on the appliances. For testing purposes, this will allow the activation of the fire system, audible alarm, shunt trip breaker (if applicable), and shut down of appliances via gas valve reset relay.

All additional PCBCORE controlled packages that are attached to the system must be in “Test” mode. This includes additional fire protection systems, Pollution Control Unit with CORE, and other hood-mounted CORE controlled protection systems.

Please note that the appliances must be started before test mode is entered on any PCBCORE protection package for proper demonstration of this function. If the fire protection system is left in “Test” mode for more than 15 minutes, the appliances will shut down. This is to prevent cooking operations from occurring while the appliances and ventilation system are not protected.

ATTENTION: All interlocked PCBCORE controlled packages must be placed into “Test” mode before cleaning the hood, Pollution Control Unit (PCU), or any other interlocked units.

Reset Overview

There are multiple actions required to reset the fire system. **The following must be completed by a Certified Fire System Technician.**

1. The duct firestat must be cooled below its internal set point.
2. The remote manual actuation device (push/pull station) must be reset by twisting the button clockwise until it resets.
3. Press the “Push To Reset Fire System” button.
4. Reset the pneumatic actuators (PAK, SVA), refer to “**Re-arming System**” on page 63.

Note: The firestat must be cool, and the remote manual actuation device (push/pull station) must be reset for this button to work.

The fire system must be re-commissioned per the manufacturer’s recommendations and guidelines by an authorized fire system distributor and/or authorized service agent.

WARNING: In the event of an actual fire, further inspections are required after the fire has been extinguished to verify the integrity of the hood, ductwork, fire sensors, fan, and fire suppression system has not been compromised. With approval from the Authority Having Jurisdiction (AHJ) or the Fire Department, proceed to restarting the fire system.

Figure 47 - Fire System Reset

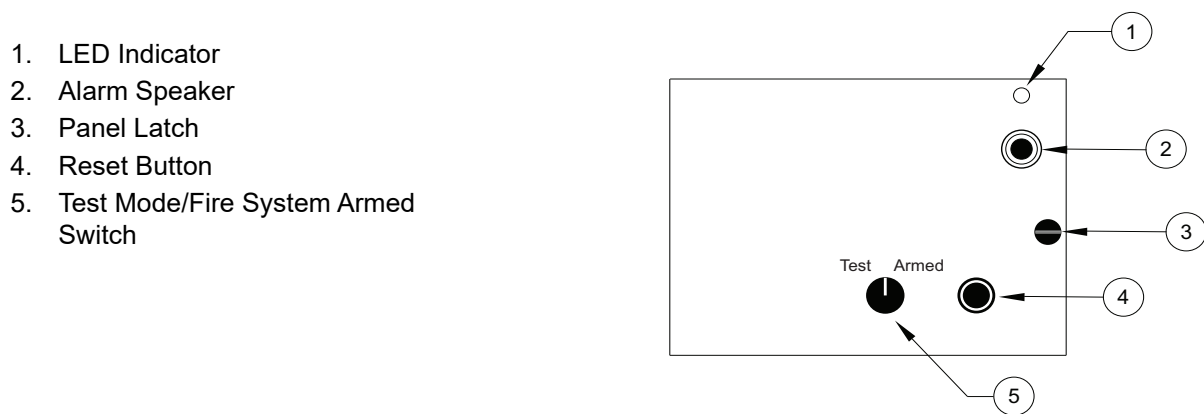

1. LED Indicator
2. Alarm Speaker
3. Panel Latch
4. Reset Button
5. Test Mode/Fire System Armed Switch

Battery Backup

Important!

The battery backup system requires that the batteries be changed every 2 years, from the date of fire system commissioning, maximum. Failure to do this will result in a void in product reliability and may cause severe damage to facility due to loss of fire protection.

The fire protection system contains a battery backup. During a power loss, the “Fire System Activated” light will flash 11 times between pauses indicating the power loss.

The batteries must be replaced every 2 years, from the date of fire system commissioning. Part number PS-1270-F2, two are required. Although the batteries are hot-swappable, which means they can be replaced while there is input power to the control, **for your safety, all sources of power must be removed from the control before replacing the batteries.** To replace the batteries, unplug the battery cable from the J1 connector on the electrical board (PCBCORE). Then remove the retaining strap holding the batteries in place. Remove the batteries from the cabinet. Transfer the fuse and cable set from the old batteries to the new batteries being extremely careful to observe the RED and BLACK lead and terminal colors. Reinstall the batteries in the cabinet and reconnect the battery plug to J1. The batteries are lead-acid type and are recyclable; **please dispose of the old batteries properly.**

During extended periods of inactivity where the fire protection system will be without AC power for more than 2 days, such as a shutdown or natural disaster, it is best to decommission the fire system by disconnecting the batteries. This will prevent any damage to the batteries through complete discharge. When the system becomes active again, commission the system by reconnecting the batteries and allow the batteries to charge for 48 hours.

The fire protection system is supplied with 14-amp hours of backup battery capacity. Per NFPA 72 10.5.6.3, the system requires 1.66 amp hours of battery capacity.

Power Supply Adjustment

To properly charge the batteries, the power supply must be adjusted to output 27.5V DC. This can be checked with an accurate digital voltmeter placed across Terminals H1D and N1D. To adjust the output voltage, place a small flat-bladed screwdriver into the yellow dial. Turn the dial clockwise, this will increase the voltage.

Figure 48 - Battery Backup

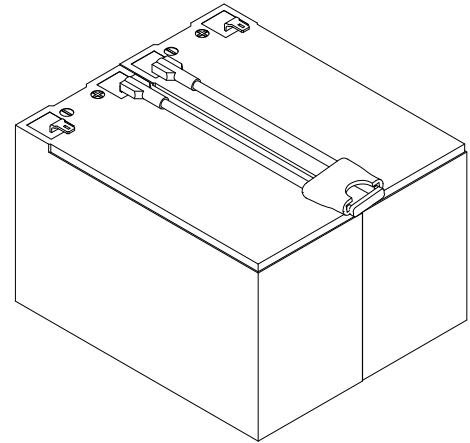
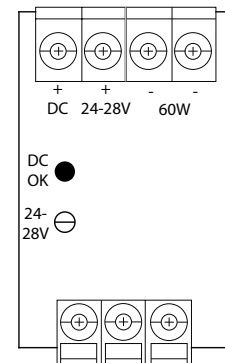

Figure 49 - Power Supply



Fire Protection System Firestat

The Firestat (**page 36**) is a device installed in the riser of the hood, at the duct connection, that measures temperature. One sensor shall be installed in each exhaust riser. Secondary downstream detectors in the duct are not required except as outlined in the **Non-Solid Fuel Appliances** and **Solid Fuel Appliances** section. Sensors are not required above each appliance or in the hood grease plenum. The standard temperature setting is 360°F. Depending on heat produced by appliance, a higher rated temperature Firestat will be required. If a temperature higher than the setpoint is sensed, the Firestat contacts will close and energize the electrical control board. The fire system will activate.

The supervised loop must be run through metallic conduit. Do not run wiring with high voltage wires. Verify all supervised loop wires are free from damage/stress. All supervised loop wires must be terminated in terminal blocks, junction boxes, and push-stations.

The Firestat has 2 black wires and 2 white wires. These wires must be connected to the supervised loop. Use high-temperature wiring when installing Firestat components. Wago connectors (part number: 221-412) must be used.

Multiple sensors are wired in parallel in the supervised loop. The Firestat may be installed on the opposite side of the quick seal for access in the duct.

Non-Solid Fuel Appliances (Rated 450°F)

Non-solid fuel appliances rated for 450°F will not require additional firestats, regardless of the configuration and length of ductwork.

Non-Solid Fuel Appliances (Rated 600°F)

Non-solid fuel appliances rated for 600°F will require downstream detection if the duct run contains any horizontal section over 25 feet in length. Downstream detection should be installed at the end of a horizontal section. Duct layouts that include less than 25 feet of horizontal ductwork will not require additional detection.

Solid Fuel Appliances (Rated 700°F)

Solid fuel appliances produce effluents that can accumulate inside the duct, especially in long horizontal duct runs. Sparks from solid fuel appliances can travel into the ductwork and create fires that occur beyond the point where the hood riser Firestat can detect them. Additional downstream Firestats ensure that these duct fires are detected and the fire system actuates. Solid fuel applications require 600°F rated Firestats, and SOLO filters. Exhaust fan(s) used with solid fuel appliances must use a steel wheel.

In addition to the 600°F rated Firestat, located in the hood riser, a second Firestat is required at the duct discharge for solid fuel applications when the ductwork exceeds 10 feet in length or contains horizontal runs. Even if the entire duct run is inaccessible, this additional Firestat is still needed. Mounting a Firestat in the fan may be an option. On duct runs longer than 50 feet, a third Firestat will be required somewhere in the duct run, ideally at the end of a horizontal run, if present. Duct runs longer than 100 feet will require additional Firestats, **contact your local sales office for more information.**

NOTE: When additional Firestats are required, install in an accessible location near an access door, hood riser, or fan. The door will provide access to install, clean, and replace the Firestat when needed. If a PCU is equipped with electronic detection, PCU Firestats can serve as downstream detectors, if present. The temperature rating of the Firestat in the duct must always match the temperature rating of the Firestat in the riser.

TROUBLESHOOTING

Table 16 lists out causes and corrective actions for possible problems with the system. Review this list prior to consulting the manufacturer.

Table 16 - Fire Protection System Troubleshooting

Problem	Potential Cause	Corrective Action
Exhaust fan is ON and supply fan will not start	Broken supply fan belt	Replace fan belt.
	Fire system not armed	Fire system distributor must arm fire system.
“Fire System Activated” light is on	Fire system is activated	Verify fire is out and reset fire system.
Audible alarm is sounding	Fire system is activated	Verify fire is out and reset fire system.
“Fire System Activated” LED is flashing	A fault has been detected in the Fire Protection System	Count the flashes and refer to “Appliance Shutdown in Fault Conditions” on page 55.
Gas Valve does not close	Debris on gas valve seal	Fully clean gas valve and strainer.
Fire System will not turn off	Duct sensor is hot	Heat has activated the duct sensor. Remove heat source or let the system extinguish the fire. Once heat source or problem is resolved, press reset button on the face of the electrical control package.
	Remote Manual Actuation Device has been pushed	Reset remote push station (twisting clockwise until reset.) once fire is out. Press reset button on the face of the electrical control package.

CORE Board Faults

When there are no faults in the fire system, the LED light will stay solid. When there is a fault, the LED light will flash with a short break. Count the flashes then wait for the short break to determine the fault.

NOTE: CORE Boards with software version 1.68 and prior will use one brief flash every 3-seconds to indicate there are no faults in the fire system.

Catastrophic faults

Number of Flashes	Fault Condition	Corrective Action
1	Invalid Activation	Check for external voltage being applied at J3-7 and J3-10.
2	Release Solenoid	Check solenoid and wiring to solenoid, replace as needed.
3	Pressure Switch	Check solenoid and wiring to solenoid, replace as needed.
4	Auxiliary Fault	Check supervised Pressure Regulating Valves (optional) and Pressure Switches (optional).
5	Microcontroller Fault	Replace CORE printed circuit board.

Critical faults

Number of Flashes	Fault Condition	Corrective Action
6	N/A	N/A
7	Supervised Loop	Check the installation of the wiring to all the manual actuation devices (push stations) and firestats. Verify connections are secure and tight. Check for open circuits in the wiring. Repair or replace wiring as needed. Refer to “Supervised Loop/Power Supply Troubleshooting” on page 56.

Important faults

Number of Flashes	Fault Condition	Corrective Action
8	Ground Fault	Check the installation of the wiring to all the manual actuation devices (push stations) and firestats. Verify connections are secure and tight. Check for a short to ground in the wiring. Repair or replace wiring as needed. Refer to page 56.
9	N/A	N/A
10	Battery Voltage Low	Replace the batteries. Wait for batteries to recharge if there was a power failure.
11	AC Power Failure	Check breakers, call power company.
12	Door Tamper Switch	Close cabinet door.
13	Test Mode	Place switch in armed position when testing is complete.
14	CORE Interlock	Check Dip Switches on all boards and RS-485 network wires connecting boards.
15	Fault on Hood in Network	Check all hoods in CORE Board network for faults.
16	Fault on PCU in Network	Check all PCUs in CORE Board network for faults.

Appliance Shutdown in Fault Conditions

The system is equipped to shut down the appliances if a fault condition is present. **Table 17** displays fault conditions that affect the appliances' fuel and power sources, alarm muting, and local trouble relay.

NOTE: CORE Boards with software version 1.68 and prior will use one brief flash every 3-seconds to indicate there are no faults in the fire system.

Table 17 - Appliance Fault Conditions

Number of Flashes	Fault Condition	Gas Valve Shut Down		Shut Down Shunt Trip Breaker and UDS Kill Switch		Mute Local Alarm 4 Hour Reset	Local Trouble Relay
		Local System	Networked System	Local System	Networked System		
Catastrophic Faults							
1	Invalid Activation	X	X	X	X		X
2	Release Solenoid	X	X	X	X		X
3	Pressure Switch	X	X	X	X		X
4	Auxiliary Fault	X	X	X	X		X
5	Microcontroller Fault	X	X	X	X		
Critical Faults							
6	N/A	-	-	-	-	-	-
7	Supervised Loop Fault	X	X	X	X		X
Important Faults							
8	Ground Fault					X	
9	N/A	-	-	-	-	-	-
10	Battery Voltage Low					X	X
11	AC Power Failure	X	X	X**	X**		X
12	Door Tamper Switch					X	
13	Test Mode	X	X	X	X		
14	CORE Interlock					X	
15	Fault on Hood in Network					X	
16	Fault on PCU in Network					X	

NOTE: The low pressure switch option is not required per product safety listings and standards. The fault is for monitoring purposes. When the fault is present for 24 hours, cooking operation will shut down.

Local Alarm Muting

Pressing the fire system reset button can mute the local alarm. This will disable the sounder for 4 hours under specific conditions. **Table 17** shows which errors can be muted. It should be noted that the fault will not clear until the fault condition is corrected.

Test Mode

Test Mode allows the system to be tested with operational appliances without discharging the system on the appliances. Once the appliances are started, test mode can be entered without the appliances shutting down for 15 minutes. However, once the fire system is activated, the shunt trip (electric appliances) and the gas valve will be locked out until test mode is deactivated. ****During AC power failure, all gas appliances will be shut down. Electrical appliances will shut down on building power loss.**

Supervised Loop/Power Supply Troubleshooting

NOTE: Place the panel in test mode during diagnostic testing.

Before troubleshooting, verify all power supplies (PS-02) are set to 27.5V DC. Verify all circuit checks from “Supervised Loop Electrical Details” on page 46. If any readings are not in range, there is an issue with that loop or associated components/wiring. Refer to **Table 18** for troubleshooting.

Table 18 - Common Wiring Troubleshooting Chart

Problem	Potential Cause	Expected Results +/- 0.2	Corrective Action
Supervised Loop Fault	Open Supervised Loop between Terminals 21 and 24.	<ul style="list-style-type: none"> Terminal 21 to PS-02 (DC-) = 26.5V DC Terminal 21 to Terminal 22 = 26.5V DC Terminal 24 to PS-02 (DC-) = 26.5V DC Terminal 24 to Ground = 1.8V DC 	Locate and repair faulty wiring in the 21-24 supervised loop.
	Open Supervised Loop between Terminals 22 and 23.	<ul style="list-style-type: none"> Terminal 22 to PS-02 (DC-) = 0V DC Terminal 23 to PS-02 (DC-) = 0V DC Terminal 23 to Terminal 24 = 26.5V DC 	Locate and repair faulty wiring in the 22-23 supervised loop.
	Open Supervised Loop Push-Station (Terminals 101 and 104)	<ul style="list-style-type: none"> Terminal 101 to PS-02 (DC-) = 26.5V DC Terminal 101 to Terminal 102 = 26.5V DC Terminal 104 to PS-02 (DC-) = 26.5V DC Terminal 104 to Ground = 1.8V DC 	Locate and repair faulty wiring in the 101-104 supervised loop.
	Open Supervised Loop Push-Station (Terminals 102 and 103)	<ul style="list-style-type: none"> Terminal 102 to PS-02 (DC-) = 0V DC Terminal 103 to PS-02 (DC-) = 0V DC Terminal 103 to Terminal 104 = 26.5V DC 	Locate and repair faulty wiring in the 102-103 supervised loop.
Ground Fault	Terminals 22 or 23 are shorted to chassis ground. *24V DC PS-02 (DC-) Wiring or Components.	Chassis Ground to PS-02 (DC-) = 24.4V DC	Locate and repair shorted wiring between 22-23 supervised loop and ground.
	Terminals 21 or 24 are shorted to chassis ground. **24V DC PS-02 (DC+) Wiring or Components.	Chassis Ground to PS-02 (DC+) = 2.7V DC	Locate and repair shorted wiring between 21-24 supervised loop and ground.
	Interlock Network Issue	Check battery voltage and supervised loop wiring with other packages that are interlocked in the network.	Locate and repair faulty wiring in the circuit. Replace batteries.
AC Power Failure	120V AC Input Power Supply Interrupted.	H1 to N1 = 110V to 125V AC	Verify constant input power between H1 and N1. Check wiring to L/N terminals on PS-02. Locate and repair faulty wiring in the circuit.
Battery Voltage Low	Faulty Battery or Power Supply (PS-02).	J1-1 to J1-2 = 23.5V to 24.5V DC	Verify there is 12V DC to each battery connection. Locate and repair faulty wiring in the circuit. Replace batteries.
	Interlock Network Issue.	Check battery voltage and supervised loop wiring with other packages that are interlocked in the network.	Locate and repair faulty wiring in the circuit. Replace batteries.
Release Solenoid	Solenoid wiring incorrect.	Check RS to N1D when: <ul style="list-style-type: none"> Wire removed from RS terminal = 15.5DC V +/- 2V RS terminal wired, connector removed = 6.5DC V +/- 2V RS terminal wired, connector installed = 0.2-0.4DC V 	Check wiring at terminals. Locate and repair faulty wiring in the circuit.
	Connector is not secured to solenoid.		Verify the connector is secured to the valve.

* Components that may cause this fault are: Gas Valve, Surfactant Pump, Water Solenoid(s), Release Solenoid(s).

** Components that may cause this fault are: 24V Relays, Trouble Relay (when energized), 24V LED Lights.

NOTE: If an abnormal reading is present, disconnect potential components/wiring one at a time, while continuing to take readings, to locate the source of the ground fault.

DIP Switch Settings

When set from the factory (**Figure 50**), switches 1, 5, and 8 are in the On (Closed) positions. Switch 2, 3, 4, 6, 7 are in the Off (Open) position. This should be considered the default positions and should not be changed.

Table 19 - DIP Switch Settings

DIP Switch #	Description				
1 through 4	DIP Switch Position				Interlock Network Address
	1	2	3	4	
	On	Off	Off	Off	1
	Off	On	Off	Off	2
	On	On	Off	Off	3
	Off	Off	On	Off	4
	On	Off	On	Off	5
	Off	On	On	Off	6
	On	On	On	Off	7
	Off	Off	Off	On	8
	On	Off	Off	On	9
	Off	On	Off	On	10
	On	On	Off	On	11
	Off	Off	On	On	12
	On	Off	On	On	13
	Off	On	On	On	14
On	On	On	On	15	
Off	Off	Off	Off	This unit is not part of an interlock network	
5	Set this switch to On (Closed) if this unit has the highest address on the interlock network. Otherwise, this switch must be Off (Open)				
6 and 7 Fire Group	6		7		Fire Group Number
	Off		Off		1
	On		Off		2
	Off		On		3
On		On		4	
8	Setting switch 8 to its On (Closed) position connects a 120 Ohm terminating resistor to the interlock network. This switch must be On if this unit is at either physical end of the interlock network cable. Otherwise, it must be Off (Open).				

Figure 50 - DIP Switch

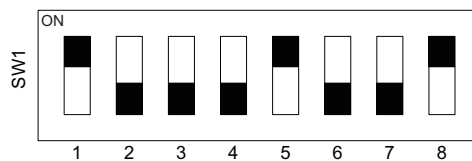

- Each unit has a unique address based on the DIP switch 1-4 settings, 15 units max on a network.
- If address is 0 (all switches off), the unit will not accept or send any network traffic.
- The unit that has switch 5 set to on will be the “master” and will be in charge of polling all the units below it and waiting for a reply. The lack of 3 replies in a row will cause an “interlock network supervision fault.” All units will be polled in a burst every 3 seconds.
- For all non-master units, the lack of being polled for 10 seconds will cause an “interlock network supervision fault.”
- Any unit detecting a fire condition will broadcast the notification once every second for as long as the condition persists.
- When the Fire condition is cleared, 10 notifications will be sent, one every second.
- Any unit detecting a supervisory fault will broadcast the notification every 2 seconds until the condition is cleared.
- When the supervisory fault condition is cleared, 10 notifications will be sent, one every 2 seconds.

Typical DIP Switch Arrangement

Only One Fire Protection System Panel on the network:

Core Board #	DIP 1	DIP 2	DIP 3	DIP 4	DIP 5	DIP 6	DIP 7	DIP 8
#1 (Hood Master)	On	Off	Off	Off	On	Off	Off	On

Two Fire Protection System (or CORE) Panels on the network:

Core Board #	DIP 1	DIP 2	DIP 3	DIP 4	DIP 5	DIP 6	DIP 7	DIP 8
#1 (2nd Hood Slave)	On	Off	Off	Off	Off	Off	Off	On
#2 (Hood Master)	Off	On	Off	Off	On	Off	Off	On

Two Fire Protection System (or CORE) Panels on the network:

Core Board #	DIP 1	DIP 2	DIP 3	DIP 4	DIP 5	DIP 6	DIP 7	DIP 8
#1 (PCU Slave)	On	Off	Off	Off	Off	Off	Off	On
#2 (Hood Master)	Off	On	Off	Off	On	Off	Off	On

Three Fire Protection System (or CORE) Panels on the network:

Core Board #	DIP 1	DIP 2	DIP 3	DIP 4	DIP 5	DIP 6	DIP 7	DIP 8
#1 (2nd Hood Slave)	On	Off	Off	Off	Off	Off	Off	On
#2 (PCU Slave)	Off	On	Off	Off	Off	Off	Off	Off
#3 (Hood Master)	On	On	Off	Off	On	Off	Off	On

Four Fire Protection System (or CORE) Panels on the network:

Core Board #	DIP 1	DIP 2	DIP 3	DIP 4	DIP 5	DIP 6	DIP 7	DIP 8
#1 (2nd Hood Slave)	On	Off	Off	Off	Off	Off	Off	On
#2 (PCU Slave)	Off	On	Off	Off	Off	Off	Off	Off
#3 (2nd PCU Slave)	On	On	Off	Off	Off	Off	Off	Off
#4 (Hood Master)	Off	Off	On	Off	On	Off	Off	On

For additional configurations, refer to **Table 19** for the electrical board (PCBCORE) DIP switch settings.

The configurations above are shown with all electrical boards (PCBCORE) in the same Fire Group and may be configured differently, even if the control panels are on the same network. Every panel with matching fire group settings (DIP switches 6 and 7) will activate simultaneously in a fire condition.

START-UP/INSPECTION TEST PROCEDURE

NOTE: This service procedure covers a single manifold system however a duplicate manifold and tank setup is possible. If you have a two manifold system, a second service kit will be required along with fittings to connect it properly. Refer to Table 23 on page 77 for service parts.

Required Tools:

- Precision Slotted Screwdriver
- Heat Gun
- Nitrogen Service Kit - single manifold only
- Balloons
- Warm Soapy Water
- 1/4" SAE Tee Connector with cap and valve core. 1/4" female knurl and 1/4" SAE male connections. Used for multiple manifold systems only.
- Micro Leak Detector
- In-Line Filter
- Digital Pressure Gauge

CAUTION! Never use magnetic tools or cause excessive vibration when the actuators are bolted to the cylinder(s).

Parts:

- Supervised Loop Wiring: Black Wire - Part #: 441601C6.FE0 & White Wire - Part #: 441601C6.FE9
- Pull Station Wiring: Belden Wire - Part #: 6320UL (or similar)
- WAGO connectors - Part #: 221-412
- Replacement PAK O-rings

Fire System Wiring Connections

- Connect the Manual Activation Device (MAD) using Belden #6320UL, 18 Gauge plenum rated wire.
- Connect all Firestats using Belden #6320UL (or similar), 18 Gauge plenum high temperature rated wire. Single hood systems with a hood mounted utility cabinet may not have any additional stats.
- **The supervised loop must be run through metallic conduit.** Do not run wiring with high voltage wires. Verify all supervised loop wires are free from damage/stress. All supervised loop wires must be terminated in terminal blocks, junction boxes, and push-stations.
- Install the 24V DC or 120V AC gas valve.
- Verify that all solenoid wires and electrical control panel wiring are secured. Any supervised loop wiring within 18 inches of the top of the hood must be high-temp wire, type MG or MGT with WAGO connectors (Part # 221-412). Type MG White (Part # 441601C6.FE0), Type MG Black (Part # 441601C6.FE9).

Preparing System for Test

- **Place all building alarm systems in test mode. Place the electric control panel in "Test" mode. Refer to Figure 51. Verify there are no supervision faults on the HMI.**
- Verify that the hood, duct, and kitchen appliances have not changed (including type, dimensions, and location) from the approved design. **Appliance drops must be between 35-50 inches from the hazard surface.**
- Verify that all cylinder discharge outlets are connected to the system.
- Verify that all cylinders are secured in their bracket(s).
- Verify that a valve cap or supervisory pressure switch (optional) is installed on each secondary cylinder Schrader valve.
- Verify that nozzle caps are installed.

NOTE: If this is the first service after installation, the PAK hose should be disconnected, and the primary and secondary valve actuators should be in the ship/test position. Refer to Figure 52 on page 60.

Figure 51 - Electric Control Panel "Test" Mode

APPLIANCE PROTECTION
TEST ARMED



PUSH TO RESET
FIRE SYSTEM



Connecting Service Test Kit

WARNING!

If the PAK or SVAs are installed on the cylinder valve during the test, the cylinders will discharge.

CAUTION!: Supplied Nitrogen Pressure Shall Not Exceed 250 psig Maximum.

NOTE: The PAK hose is shipped disconnected, and the PAK/SVA(s) are shipped in the Ship/Test position

- Check the quantity of Schrader valves on the tank cylinder assembly.
 - Tank assemblies with one Schrader valve:
 - Quickly disconnect the PAK hose to minimize nitrogen loss. Verify a Supervisory Pressure Switch is active on the HMI.
 - Tank assemblies with dual Schrader valves:
 - **If this is the first installation/start-up procedure, confirm a Supervisory Pressure Switch fault is active.** Then, connect the PAK hose to the tank Schrader valve after the PAK/SVA actuators are confirmed in the ship/test position. Apply Leak Lock joint sealing compound on the sealing surface of the Schrader valve when connecting the PAK hose to the tank assembly.
 - **NEVER DISCONNECT the PAK hose from the tank during normal 6-month inspections. The primary tank secondary Schrader valve will be utilized for servicing the system.** A Supervisory Pressure Switch fault should not be active on the HMI.

NOTE: PAK hoses with knurled fitting must ONLY be tightened by hand and not with a tool. If the PAK hose with a hex fitting was loosened for any reason, this fitting must be torqued to 15 in-lbs.

- Remove the PAK and any Secondary Valve Actuators (SVA) from their cylinder. Place PAK and SVAs in the ship/test position. Verify that the PAK and SVAs are securely mounted to the bracket. Refer to **Figure 52**.

Figure 52 - System Preparation

1. Primary Supervisory Pressure Switch
2. PAK Hose Disconnected
3. Secondary Supervisory Pressure Switch (optional)
4. PAK/SVA in the Ship/Test Position

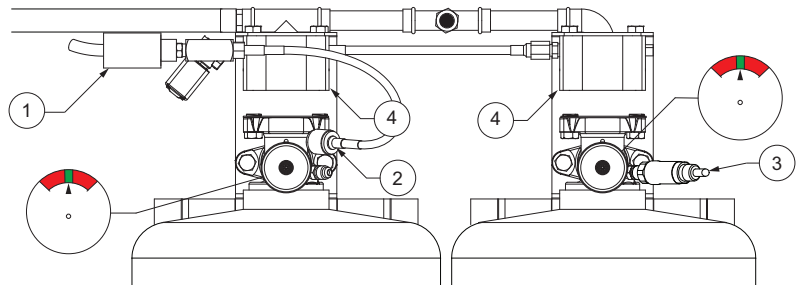

- Connect the Nitrogen Service Cylinder via the 1/4" refrigerant test hose with an inline filter. If the filter has a directional airflow arrow, verify correct orientation. Refer to **Figure 53 on page 61**.
 - For a single Schrader valve, connect the PAK hose to the inline filter.
 - For dual Schrader valves, connect a secondary 1/4" refrigerant test hose to the open secondary tank Schrader valve. Connect the end of the hose to the filter.
- Verify that the pistons in the PAK and SVAs are in the set position. The plunger is not actuated. Refer to **Figure 55 on page 62**.
- Connect a 1/4" pressure gauge to the Schrader service valve of the PAK assembly. Verify the pressure reads 0 psi. Refer to **Figure 53**.
- Verify all secondary actuator hoses are connected to the appropriate PAK/SVAs. Tighten connections.
- Verify the actuation line vent limiting orifice is installed and tight in the last actuator on the system (last SVA or PAK if there are no secondary cylinders). **Do not use pipe dope or tape on the orifice.**
- Verify that the Primary Supervisory Pressure Switch is installed securely on the PAK.
 - Optional Feature: Secondary tanks may also have Supervisory Pressure Switches installed, verify all switches are properly secured to all secondary tanks.
- Verify the PAK solenoid is de-energized.
 - Open the Nitrogen Cylinder. Adjust the pressure to 225 psig.
 - Monitor the pressure gauge on the PAK. The pressure must not read above 0.5 psi for 15 minutes. This indicates the primary actuator solenoid is in the de-energized state and will not let pressure through as intended. The gauge may fluctuate between 0 and 0.5 psi.

CAUTION!: If pressure reads above 0.5 psi, contact Service at 1-866-784-6900.

- Close the Nitrogen Cylinder.
- Remove the pressure gauge on the PAK.

Figure 53 - Service Test Tank Details

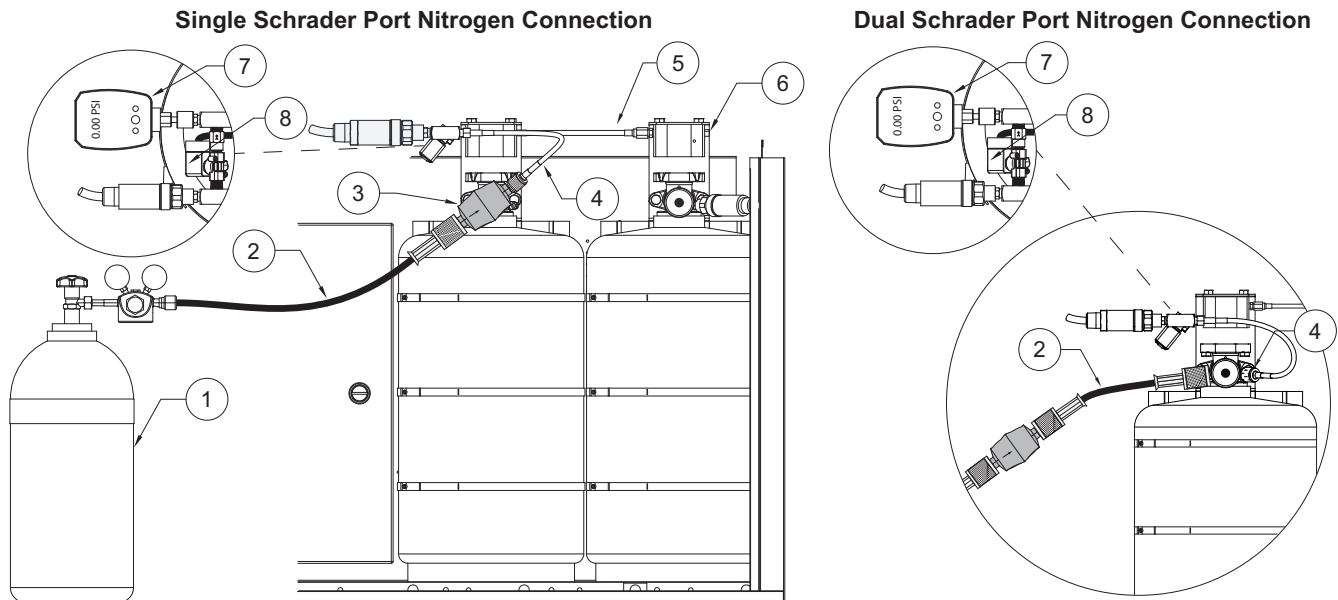

- | | |
|---|------------------------------|
| 1. Nitrogen Service Cylinder with regulator attached | 5. Secondary Actuator Hose |
| 2. 1/4" Refrigerant Test Hose (Long) | 6. Vent Limiting Orifice |
| Additional hoses/lengths required for servicing. | 7. Digital Pressure Gauge |
| 3. 1/4" Male to Male Inline Filter | 8. Primary Actuator Solenoid |
| 4. PAK Hose Connection | |

NOTE: Pressure gauge minimum requirements; 1/4" female flare, 0-250 psi, resolution 0.5 psi, accuracy +/- 1% FS. The inline filter minimum requirements; 1/4" male flare, 40 micron, 250 psi.

Balloon Test Procedure

NOTE: The following should be tested with battery power only (A/C power disconnected) and then tested with A/C power connected.

- Connect an additional 1/4" refrigerant test hose from the service Schrader valve of the PAK assembly (45° depressor connection) to the distribution piping service port (low-loss fitting threaded into hose straight connection). Refer to **Figure 54**.
- Check that the pistons in the PAK and SVAs are still in the set position.
- Remove the nozzle caps from the nozzles.
- Remove hood filters. This will expose the Firestat(s) and the duct and plenum drops.
- Place testing balloons over all nozzles (appliance, duct, and plenum).
- Open the Nitrogen Service Cylinder. Adjust the pressure to 200 psig.

CAUTION!: Supplied Nitrogen Pressure Shall Not Exceed 250 psig Maximum.

- Place the system in "Armed" mode.
- Lift the cover to the manual activation device and "push" to activate the fire system. Refer to **Figure 55**.
- When testing with A/C power, verify the Electrical Control Package (ECP) has activated. The audible alarm will sound, and the system is in a fire condition. The HMI will flash FIRE on the screen.
- Verify the PAK and all SVAs have actuated. The piston should be fully extended and in a locked position. Refer to **Figure 55**.
- Verify that there are no leaks in the actuation line, except through the vent limiting orifice.
- Verify that the solenoid is in the energized state.
- Verify all balloons are filled.
- Verify fuel to all appliances under the protected hood has shut off.
- Verify the makeup air supplied to the hood has shut off.
- If all of the above is confirmed, reset the control panel. The manual activation device can be reset by twisting the push button in a clockwise motion. Press the "Push To Reset" button. Refer to "**Reset Overview**" on **page 50**.
- Close the Nitrogen Cylinder. Remove all balloons from the nozzles.

Figure 54 - Additional 1/4" Test Hose

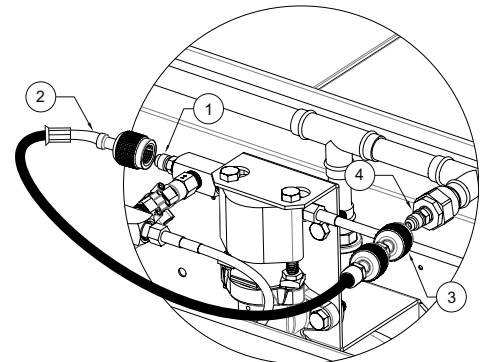

1. Schrader service valve of the PAK assembly
 2. 1/4" Refrigerant Test Hose (Short)
 3. Low-loss Fitting Straight Adapter
 4. Distribution Piping Service Port
- Additional hoses/lengths required for servicing.**

Figure 55 - Balloon Test

Manual Activation Device (MAD)

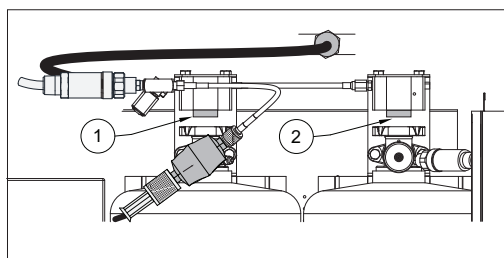
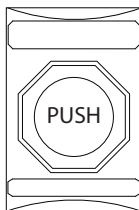

1. PAK Actuated
2. SVA Actuated

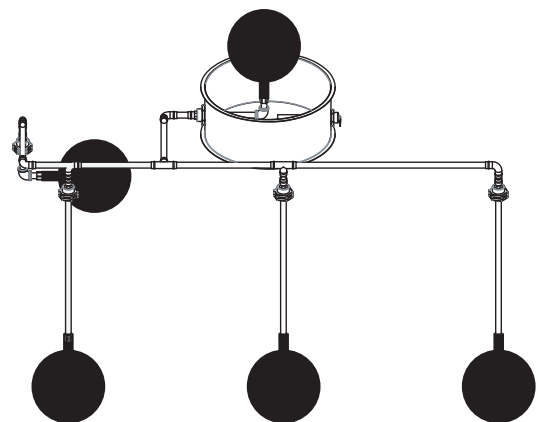

Firestat Test Procedure

NOTE: The following should be tested with battery power only (A/C power disconnected) and then tested with A/C power connected.

ATTENTION: You do not need nitrogen for this test.

CAUTION!: The use of a torch or flame is strictly prohibited.

- Use a portable heat source to apply heat to the duct Firestat in accordance with the manufacturer’s instructions. Please refer to applicable detector manufacturer’s manual. Refer to **Figure 56**.
- When the Firestat’s heat set point is reached, the fire system will activate. Some residual nitrogen from the test cylinder may release.
 - When performing this test with battery power only, check the CORE-board fire status light.
 - When performing this test with A/C power, the exhaust fan will activate. Depending on the hood lights activation setting, they will turn on or off.
- Check all Firestats in the system.
- After the system is tested, install nozzle caps, and install hood filters.

Figure 56 - Firestat Riser Location

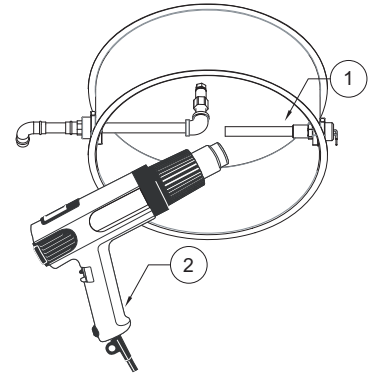

1. Firestat
2. Heat Gun

Disconnecting Service Cylinder Tank

- Place the TANK fire system into “Test” mode.
- Relieve pressure from the Nitrogen Cylinder.
 - Cylinder assemblies with one Schrader valve:
 - Slowly disconnect the inline filter from the PAK hose.
 - Cylinder assemblies with dual Schrader valves:
 - Check all cylinder gauges to confirm proper pressure is within the “green” range. If pressure is low, refer to **“Adding Nitrogen to Tank(s)” on page 68**.
 - Slowly disconnect the test hose with inline filter from the tank cylinder.
- Relieve pressure in the actuation line. Slowly disconnect the test hose from the PAK service valve.
- Disconnect the test hose from the fire system distribution piping service port. Remove low-loss fitting adapter.

Re-arming System

- Reset each PAK and any SVAs by pushing the spring-loaded pin on the piston. Press the piston into the body of the actuator.
- Verify residual pressure is relieved at Schrader valve.

NOTE: If a PAK/SVA fails to operate or cannot be properly reset, the unit must be replaced. Refer to page 67 for replacement procedures.

- Verify all of the actuation lines between the PAK and SVA(s) are secure and tight. Place Schrader valve cap on the fire system distribution piping service port.
- Check all cylinder gauges to confirm proper pressure is within the “green” range. If pressure is low, add nitrogen. Refer to **“Adding Nitrogen to Tank(s)” on page 68**.
- Re-arm the control panel by placing the package in “Armed” mode.

Figure 57 - Resetting PAK/SVA(s)

1. PAK in Ship/Test Position
2. SVA in Ship/Test Position
3. Distribution Piping Service Schrader Valve
4. Primary Actuator Hose
5. Actuator Activated
6. Actuator Set Position

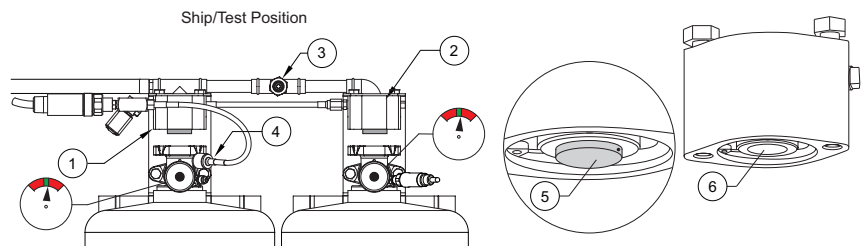

NOTE: Tanks should never be filled with agent in the field.

Leakage Testing

- Connect a 1/4" pressure gauge to the Schrader service valve of the PAK assembly. Verify the pressure reads 0 psi. Refer to **Figure 58**.
- Prepare the tank cylinder assembly for leakage testing.
 - Cylinder assemblies with one Schrader valve:
 - Inspect the PAK hose O-ring. Replace O-ring if damaged or deformed. Refer to **"TANK FIRE SUPPRESSION SYSTEM PARTS"** on page 77.
 - Quickly connect the PAK hose to the Schrader valve on the primary cylinder to minimize nitrogen loss. Apply Leak Lock joint sealing compound on the sealing surface of the Schrader valve when connecting the PAK hose to the tank assembly.
 - Cylinder assemblies with dual Schrader valves:
 - Place Schrader cap back on the tank cylinder secondary Schrader valve.

NOTE: PAK hoses with knurled fitting must ONLY be tightened by hand and not with a tool. If the PAK hose with a hex fitting was loosened for any reason, this fitting must be torqued to 15 in-lbs.

- Monitor the pressure gauge on the PAK. The pressure must not read above 0.5 psi for 15 minutes. This indicates the solenoid is in the de-energized state and will not let pressure through as intended. The gauge may fluctuate between 0 and 0.5 psi.

CAUTION!: If pressure reads above 0.5 psi, immediately remove the primary actuator hose from the primary tank. Contact Service at 1-866-784-6900.

- Verify that the pistons in the PAK and SVAs are in the set position and not actuated. Refer to **Figure 57** on page 63.

Figure 58 - Leakage Test Setup

1. PAK Reset and in the Ship/Test Position
2. SVA Reset and in the Ship/Test Position
3. PAK Hose Connected to Tank
4. Digital Pressure Gauge

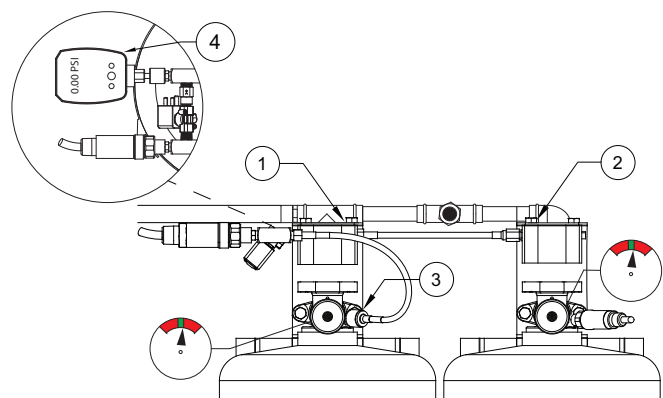

- Install the PAK and any SVAs onto their respective cylinders. Refer to **Figure 59**.
- Remove the pressure gauge on the PAK. Place the Schrader valve cap back onto the service port of the PAK assembly. Tighten the cap.
- Spray the primary charge hose connection with a micro leak detector to check for leaks.
- Verify that the Supervisory Pressure Switches have reset per the control panel manual instructions.
- The system should be in the "Armed" position, and no faults should be active on the HMI when finished testing.

Figure 59 - PAK/SVA(s) Installed

1. PAK Installed
2. Schrader Cap
3. SVA Installed

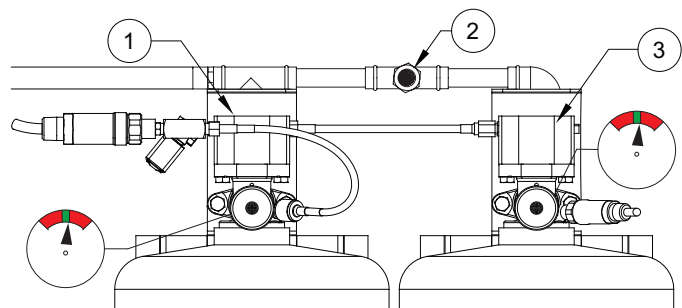

MAINTENANCE

NOTE: It is the responsibility of the system installer to review system operation and owner obligations, and to provide any necessary literature to the owner at the time of system installation.

This section contains the inspection and maintenance instructions for the TANK Fire Suppression extinguishing system. These procedures must be performed in accordance with NFPA 17A and the National Fire Code of Canada as applicable. If problems arise, corrective action must be taken.

Every Month (System Owner)

Refer to the cylinder nameplate for proper inspection and maintenance instructions. Inspections are required to ascertain that the system is operable and that no changes have occurred, which would compromise the effectiveness of the system. A record of the monthly inspection is to be kept reflecting the date inspected, initials of the person performing the inspection, and any corrections required. If any discrepancies are noted while making this inspection, **DO NOT CONTINUE OPERATING COOKING APPLIANCES**. Immediately contact a factory trained distributor for service and/or repair.

The following procedure is to be performed by the Owner of the system on a monthly basis:

Table 20 - Owner's Monthly Maintenance

Checkbox	Procedure
	Verify the extinguishing system is in its proper location.
	Inspect all system components, agent distribution pipe, and conduit runs for physical damage and/or displacement.
	Inspect all nozzles caps are in place and intact. Check for possible obstructions to the discharge of the wet chemical.
	Inspect each Cylinder and Valve Assembly. The indicator on the pressure gauge should be in the "green" range (200 psig). The cylinder should not show evidence of corrosion or damage.
	Verify that manual release stations are unobstructed and in clear view and are labeled for intended use.
	Verify all tamper seals are intact, and the system is in a ready condition.
	Verify the inspection tag or certificate is in place and current.
	Verify the hood, duct, and protected cooking appliances have not been replaced, modified, or relocated.

Every Six Months (Factory Trained Distributor)

All systems shall be inspected and serviced semi-annually by a factory trained distributor.

1. Place the control panel in “Test” mode and ensure there are no supervision faults, refer to “**Reset Overview**” on page 50.
2. Verify that the system design and installation are adequate to protect the hazard area and conform to the instructions in this manual. Check the following:
 - All equipment requiring fire protection within the hazard area is protected.
 - There have been no unauthorized alterations to the protected area or equipment, or to the wet chemical system.
 - All cylinder mounting brackets are securely fastened to the hood.
 - Verify all cylinders are pressurized within the “green” range.
 - Leak Lock joint sealing compound was applied when connecting the PAK hose to the tank assembly.
 - Check hose connections with soapy water to check for leaks.
 - All nozzles are properly aimed, secured, and located within the proper distance from the protected equipment. Each nozzle should be clean and equipped with a cap.
 - All piping joints and pipe supports are securely fastened.
 - The pipe lengths, sizes, fittings, and material are as specified in this manual.
 - All wiring is in compliance with local codes.
 - All field wiring is free of ground fault or short-circuit conditions.
 - All system components and installation material are as specified in this manual.
3. Perform Start-up/Test Procedure. Refer to “**START-UP/INSPECTION TEST PROCEDURE**” on page 59.

Every Two Years

1. Replace batteries. The replacement battery part number is PS-1270-F2; two are required. Once the battery is disconnected, the connected equipment is not protected from power outages. The new battery must be installed immediately. Refer to the replacement battery installation guide for more details.
2. Inspect the condition of all wires and plumbing. Plumbing should be free of corrosion, and wire insulation must be in good condition.

Every Twelve Years

The 12-year maintenance is typically done in conjunction with the semi-annual maintenance. These procedures shall be performed in addition to the tests conducted at Semi-Annual intervals. Refer to “Every Six Months (Factory Trained Distributor)”.

Decommissioning

If it should become necessary to disconnect the CORE system from AC power for an extended period of time (more than 2 days), the batteries should be disconnected to prevent them from being damaged due to complete discharge.

Agent Cylinder Tanks

Each cylinder must be replaced every 12 years. For information on replacing cylinders, refer to “**POST-DISCHARGE MAINTENANCE**” on page 69.

Actuation Hoses

All actuation hoses must be hydrostatically tested (at 500 psi test pressure) or replaced every 12 years in accordance with NFPA 17A.

Conditional Maintenance

Replacing A Primary Actuation Kit

If a PAK fails to operate during system testing, follow these steps to replace the PAK:

1. Ensure the primary actuation hose is not connected to the primary cylinder or a nitrogen pressure supply system.
2. Remove the supervisory pressure switch installed on the PAK.
3. If applicable, disconnect the secondary actuation hose from the PAK.
4. Loosen the PAK shipping bolts from the top of the bracket, slide the unit back and remove it from the bracket.
5. Loosen the shipping bolts on the new PAK. Slide the unit into the bracket. Tighten the shipping bolts to ensure the PAK is held firmly but can still be slid back for installation to the cylinder valve.
6. If applicable, remove the side vent limiting orifice on the PAK and install in the secondary actuation hose.
7. Install the supervisory pressure switch onto the new PAK.

Replacing A Secondary Valve Actuator

If an SVA fails to operate during system testing, follow these steps to replace the SVA:

1. Ensure the primary actuation hose is not connected to the primary cylinder or a nitrogen pressure supply system.
2. Disconnect any secondary actuation hose connecting the SVA to the PAK or other SVAs.
3. Loosen the SVA shipping bolts from the top of the bracket, slide the unit back and remove it from the bracket.
4. Loosen the shipping bolts on the new SVA. Slide the unit into the bracket. Tighten the shipping bolts to ensure the SVA is held firmly but can still be slid back for installation to the cylinder valve.
5. If applicable, remove the side vent limiting orifice(s) on the SVA and connect the SVA to any applicable secondary actuation hoses.

Adding Nitrogen to Tank(s)

NOTE: Verify the pressure loss is not due to a discharge or unknown issue. Spray the pressurized PAK, SVA, and tank cylinder assemblies (PAK hose connection and pressure switches) at all fittings with a micro leak detector. Repair or replace components that show signs of leaking/damage.

Table 23 on page 77 provides all required components/part numbers to service low pressure tank(s). Refer to **Figure 60** for assembling service kit. After the low pressure condition is identified and fixed, follow these steps to add nitrogen.

- Place the system in “Test” mode.
- Unbolt PAKs/SVAs from tank(s) and secure to tank bracket.
- Determine TANK Schrader valve ports. Refer to **Figure 60**.
 - Cylinder assemblies with one Schrader valve, disconnect the PAK hose from the primary Schrader valve, if already connected.
 - Cylinder assemblies with dual Schrader valves, remove Schrader cap from the secondary Schrader valve.
- Connect a Nitrogen Service Cylinder via the 1/4” refrigerant test hoses with an inline filter to the 1/4” to the Schrader valve fill port.
- If the filter has a directional airflow arrow, verify correct orientation. Arrow should be pointing away from the nitrogen tank and toward the fire system tank.

CAUTION!: Supplied Nitrogen Pressure Shall Not Exceed 250 psig Maximum.

- Open the Nitrogen Service Cylinder. Adjust the pressure to 225 psig.
- Pressurize the tank to 200 psig. The green indicator range is 175 to 225 psig.
- Close the Nitrogen Service Cylinder.
- Remove test hoses from the Schrader valve.
- Prepare tanks for final connections.
 - Cylinder assemblies with one Schrader valve, connect the PAK hose to the primary Schrader valve.
 - Cylinder assemblies with dual Schrader valves, place the Schrader cap on the secondary Schrader valve.
- Verify PAK/SVA are still in the set position.
- Remove PAKs/SVAs from the tank bracket and secure to the tanks. Tighten hardware.
- Connect a 1/4” pressure gauge to the Schrader service valve of the PAK assembly. Pressure should read 0 psi.
- Spray the pressurized system components and fittings with micro leak detector. Monitor the pressure gauge on the PAK. The pressure must not read above 0.5 psi for 15 minutes. Pressure may fluctuate between 0 - 0.5 psi.

CAUTION!: If pressure reads above 0.5 psi, contact Service at 1-866-784-6900.

- Place the system in “Armed” mode.
- Finalize Start-up/Test procedure. Continue to **“START-UP/INSPECTION TEST PROCEDURE” on page 59.**

Figure 60 - Service Kit Set-up

1. Nitrogen Service Cylinder
2. Pressure Regulator
3. 1/4” Refrigerant Test Hose (60” Long)
4. 1/4” Male to Male Inline Filter
5. 1/4” Refrigerant Test Hose (36” Long)
6. Digital Pressure Gauge
7. Primary Schrader Valve (Single Schrader Port)
8. Secondary Schrader Valve (Dual Schrader Port)
9. PAK Hose (Connected to TANK)

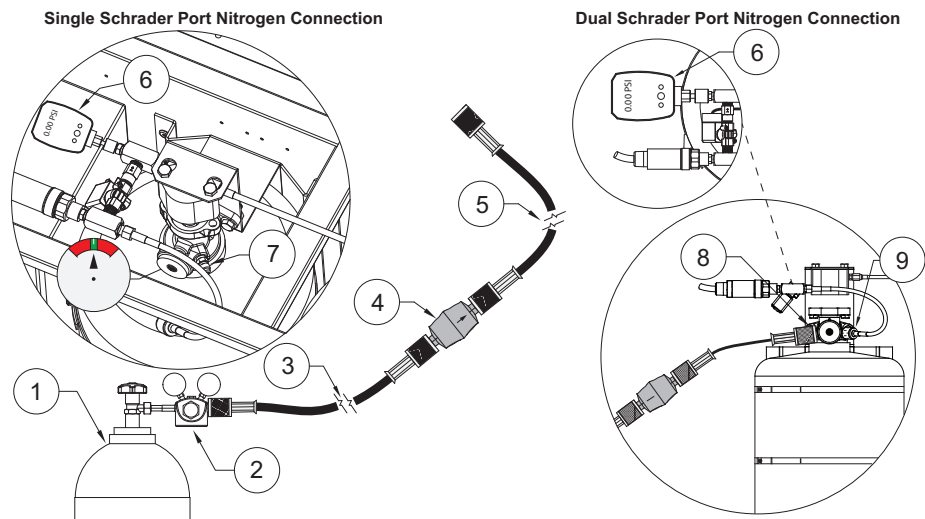

POST-DISCHARGE MAINTENANCE

General Information

Liquid Fire Suppressant, the Aqueous Potassium Carbonate (APC) base wet chemical used in the TANK Fire Suppression extinguishing system, is non-toxic. However, any food or cooking oils that have been contaminated with wet chemical agent should be discarded. Refer to Safety Data Sheet (SDS).

After any system discharge, it is best to clean the area as soon as it is safe to do so. Prolonged exposure of wet chemical to equipment can result in localized corrosion due to moisture in the air. Clean up should be completed within 24 hours of any system discharge.

TANK Fire Suppression cylinders need to be replaced every 12 years, and after any system discharge.

Appliance Cleanup

No unusual cleanup procedure is required. The reaction of the wet agent and the grease is one of saponification, and it produces a foam that can be wiped off. After the appliances have completely cooled, the residue from the discharge may be cleaned up using a wet cloth or sponge. Ensure that all fuel and electric power to the area has been shut down. Wear rubber gloves and eye protection while cleaning. If skin or eyes come in contact with the agent, flush thoroughly with water.

WARNING!

Do not disturb the foam until the cooking appliances, plenum, and duct have cooled sufficiently. Do not put water on hot grease as this will cause violent steaming and spattering.

WARNING!

APC wet agent is electrically conductive. To avoid electrical shock, de-energize all electric circuits to appliances, outlets, and wiring by disconnecting or turning off the electric power at the main fuse or circuit breaker box. Do not cleanup APC wet agent or touch electric appliances, outlets, power cords, or other wiring with electric power on.

Cleaning Distribution System

The TANK Fire Suppression extinguishing system must have all discharge piping and nozzles flushed out with water after any discharge, as detailed in the following procedures.

Cleaning Nozzles

1. Remove all nozzles from the system.
2. Inspect each nozzle & filter and remove any debris.
3. Clean nozzle and strainer by flushing thoroughly with warm soapy water. Remove any foreign matter that could impede flow.
4. Run water through the nozzle tip to ensure the orifice is not clogged.
5. Thoroughly dry nozzles with dry air or nitrogen and set aside.

Flushing the Distribution Pipe Network

Before starting the flushing procedure, inspect the complete piping network, and replace any pipe or fittings that have been subjected to direct flame or excessive heating. The following procedure describes flushing the pipe network with a spare/test cylinder. The pipe network can also be flushed utilizing an external water supply if available.

Flushing Procedure with Spare/Test Cylinder

- Check the pressure gauge on each cylinder to ensure it has been depressurized.
- Clean the area with warm soapy water, and rinse with water. Dry thoroughly with dry air or nitrogen.
- Disconnect the Primary Actuator Kit (PAK) stainless steel hose from the primary cylinder valve.
- Remove all cylinders from the system. Refer to “**Removing a Cylinder Tank (Empty or Storage)**” on **page 73**.
- Fill test cylinder(s) with water and pressurize.
- Install a test cylinder for each removed cylinder. Refer to “**Install New Cylinder Tank(s)**” on **page 74**.
- Attach a suitable container (or hose to a container or other point of disposal) at each pipe outlet where a nozzle was installed to collect the water discharge.
- Install the PAK and SVAs onto their respective cylinders.
- Re-arm the control panel by placing the package in “Armed” mode.
- Connect the primary actuator hose securely to the Schrader valve on the primary cylinder.

NOTE: PAK hoses with knurled fitting must ONLY be tightened by hand and not with a tool. If the PAK hose with a hex fitting was loosened for any reason, this fitting must be torqued to 15 in-lbs.

- Activate the system using the manual activation device.
- Once the system is fully discharged of water, reset the system. Refer to “**Reset Overview**” on **page 50**.
- Remove containers or hoses from all nozzle location pipe outlets.
- Remove test cylinders.
- Connect a nitrogen service tank to system piping service port and blow out the discharge piping to remove all excess water. Disconnect the nitrogen service tank. Refer to “**Dry the Lines**” on **page 72**.
- Install new cylinders at each location. Refer to “**Install New Cylinder Tank(s)**” on **page 74**.
- Re-install nozzles, ensuring that all nozzles are in the correct location and properly aimed.
- Complete the Start-up/Test Procedure. Refer to “**START-UP/INSPECTION TEST PROCEDURE**” on **page 59**.

NOTE: Tank cylinder(s) should never be filled in the field with agent.

Flushing Procedure with an External Water Supply

The procedure is used for flushing out the fire system piping after a fire system discharge. **Tank cylinder(s) must be in place when flushing the system.** Refer to **Figure 61** for testing setup.

Parts:

- Tank Flushing Adapter
- Bucket Support Bracket
- Buckets
- Water Hose
- Nitrogen Service Kit
- Silicone Lubricant
- 1/4" SAE Tee Connector with cap and valve core. 1/4" female knurl and 1/4" SAE male connections. Used for multiple manifold systems only.

Flush the System

- Remove the appliance nozzle that is furthest away from the utility cabinet.
- Use a 3/8" to 3/4" flushing adapter to attach the hose to the nozzle drop. Attach a water hose to the flushing adapter and the other end to a water source.
- Hang the bucket support brackets and buckets on the applicable drops. If possible, connect a hose to the grease spout and route the hose to the nearest floor drain.
- Flush with water for a minimum of one minute. Larger systems will take longer than a minute.

Figure 61 - Flushing System with External Water Supply

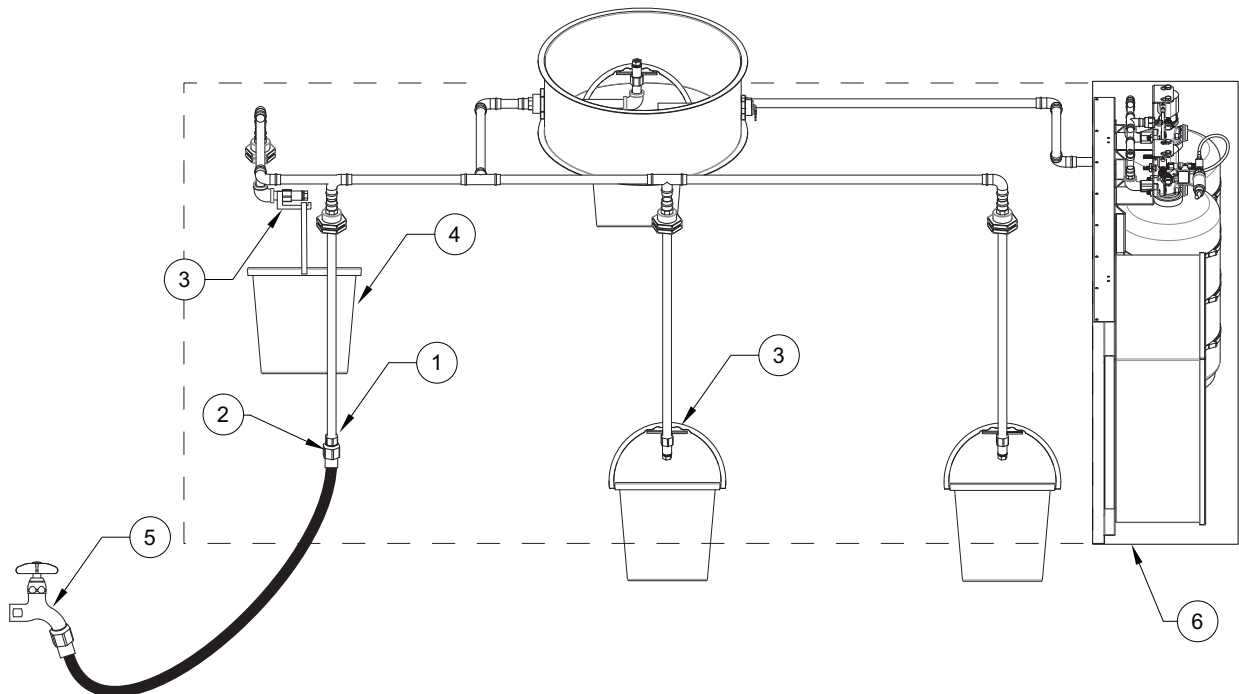

1. Nozzle Furthest from Utility Cabinet
2. 3/8" to 3/4" Tank Flushing Adapter
3. Bucket Support Bracket
4. Buckets
5. External Water Supply
6. Utility Cabinet

- Remove flushing adapter. Reinstall the nozzle and hang a bucket.
- When reinstalling nozzles, ensure that all nozzles are in the correct location and properly aimed.

Dry the Lines

- Connect the nitrogen line directly to the distribution piping service Schrader valve on the manifold line. Refer to **Figure 62**.
- Set your pressure regulator to 100 psi and blow down the lines for a minimum of 30 seconds. Larger systems may take longer.

Figure 62 - Connecting Nitrogen to Dry Lines

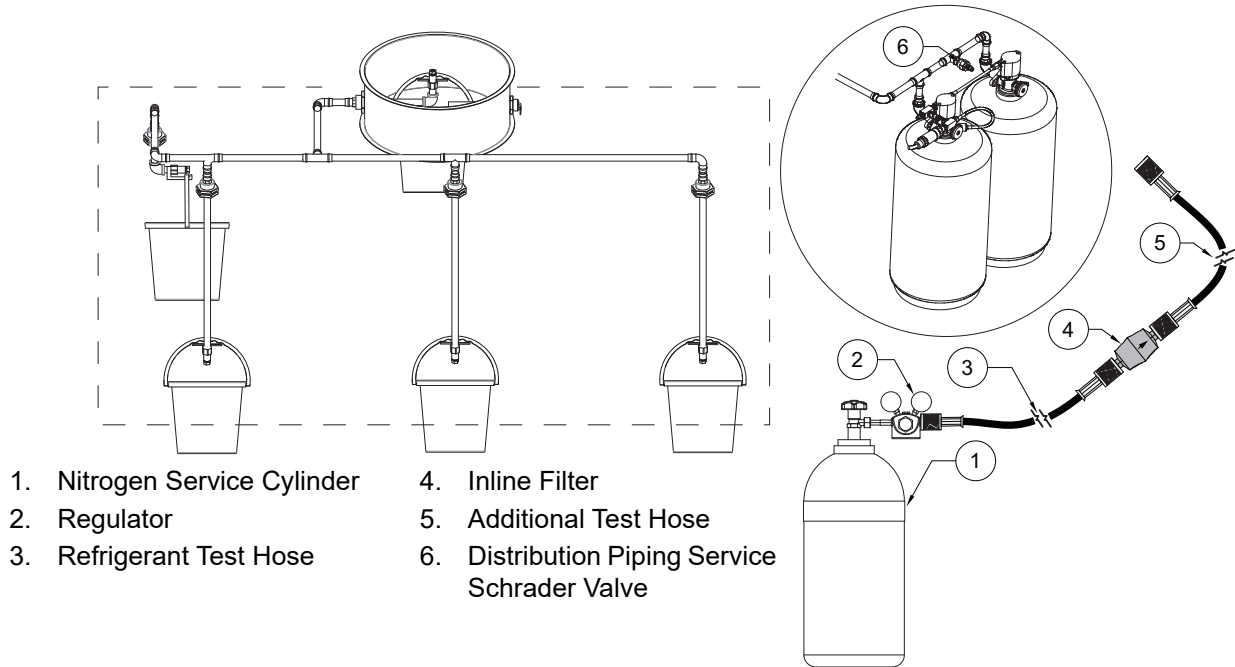

- Remove nitrogen line from the distribution piping service Schrader valve.
- Remove all hoses and buckets.
- Install nozzle caps on nozzles.

Cylinder Tank Maintenance

TANK Fire Suppression cylinders need to be replaced every 12 years, and after any system discharge.

WARNING!

Never assume that a cylinder is unpressurized. Handle all cylinders as if they are pressurized until verified otherwise. Pressurized cylinders are extremely hazardous.

When performing any cylinder maintenance procedure, the cylinder must be properly secured to a rigid structure capable of withstanding the full thrust that would result if the valve were to open inadvertently.

Any time a cylinder assembly is unsecured, the anti-recoil plate must be installed on the valve outlet to provide a safe, controlled discharge in the event of accidental actuation.

Failure to take proper precautions could result in death, serious personal injury and/or property damage.

Removing a Cylinder Tank (Empty or Storage)

- Unbolt the actuators from the tanks and bolt into shipped position. Repeat for all additional actuators.
- Disconnect the PAK hose.

IMPORTANT: If tank(s) will be stored for an extended period, you must prevent debris from entering the system. Cover the discharge outlet (tank) and discharge adapter (system piping). Install the Valve Protection Plate and Anti-recoil Plate onto the cylinder.

- Use a 1/2" and 9/16" box end wrench to remove the cylinder mounting bolts from the bracket.
- Loosen the tank straps, and remove the tank. Repeat for additional tanks.
- For each secondary cylinder, perform the following before moving to the next cylinder:
 - Remove the Supervisory Pressure Switch from the cylinder valve if applicable.
 - Loosen the cylinder bolts holding the valve to the discharge adapter and cylinder bracket.
 - Loosen the tank straps holding the cylinder in place.
- Pull the cylinder out from the bracket. Refer to **Figure 63**.

Figure 63 - Tank Removal Process

1. PAK in Ship/Test Position
2. SVA in Ship/Test Position
3. PAK Hose
4. Secondary Supervisor Pressure Switch (Optional)
5. Cylinder Mounting Bolts
6. Tank Straps

NOTE: Tanks should never be filled with agent in the field.

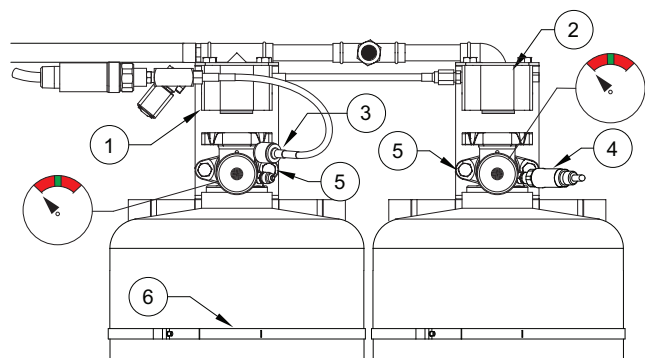

Install New Cylinder Tank(s)

- Remove the anti-recoil plate.
- Install the tank by fully inserting the tank into the adapter. Apply some silicone lubricant to the adapter and o-ring to ensure a smooth installation.
- Install and tighten the 2 bolts to hold the tank onto the bracket. The square nut can be tightened with a 9/16" box end wrench; the bolt head can be tightened with a 1/2" box end wrench.
- Tighten the middle tank strap to help support the weight of the tank and to assist in lining up the bolts.
- Tighten the other two tank straps.
- Repeat for all other tank cylinder(s) in the system.
- Complete the Start-up/Test Procedure. Refer to **"START-UP/INSPECTION TEST PROCEDURE"** on page 59.

Figure 64 - Installing Tank Cylinder(s)

1. Anti-Recoil Plate
2. Valve Protection Plate
3. Cylinder Assembly
4. Discharge Adapter
5. Cylinder Mounting Bolts
6. Tank Straps

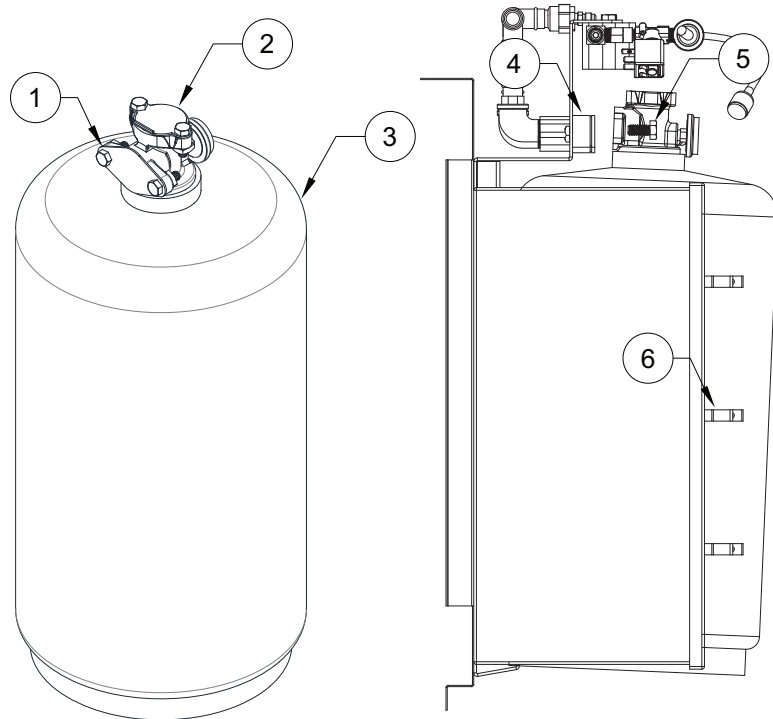

Depressurizing a Cylinder Tank

WARNING!

Failure to correctly secure the hose could result in death, serious bodily injury, and/or property damage.

1. Secure the cylinder in a chain vice, strap vice, or similar device.
2. Prepare high-pressure discharge hose with a spare nozzle on the end.
3. Remove the anti-recoil plate from the cylinder outlet and install the discharge adapter.
4. Install a ball valve onto the discharge adapter outlet. Refer to **Figure 65**.
5. Attach the discharge hose with nozzle to the ball valve outlet.
6. Attach the hose and discharge adapter assembly to the cylinder valve outlet.
7. Insert the opposite end of the hose into an appropriate container for the wet chemical agent.
8. Ensure that the hose is secure and will not come loose or separate from the container.
9. Install a Secondary Valve Actuator (SVA) onto the cylinder valve.
10. Connect the nitrogen service cylinder to one of the SVA ports, and a SVA vent limiting orifice in the opposite port.
11. Ensure that the ball valve on the discharge assembly is in the closed position.
12. Open the nitrogen supply, slowly increase pressure until the SVA actuates. Turn off nitrogen supply.
13. Carefully open the discharge valve.
14. Monitor the discharge to prevent spillage and to ensure that the hose remains secure.
15. Control the rate of discharge via the ball valve.
16. If applicable, stop the flow and change containers.
17. When the discharge is complete, turn off the nitrogen service cylinder supply.
18. Check that the cylinder gauge indicates no pressure, and carefully depress the Schrader on the cylinder valve. Check for any possible flow/leakage of nitrogen.
19. Slowly disconnect the nitrogen supply, relieving pressure from the SVA.
20. Remove the SVA from the valve.
21. Remove the valve/siphon tube assembly by unthreading the valve counterclockwise from the cylinder.
22. Invert the cylinder to remove any residual wet chemical.
23. Clean the cylinder and threads with warm soapy water and rinse with clean water.
24. Blow out any residual moisture from the cylinder and threads with dry air or nitrogen.

Figure 65 - Cylinder Discharge Assembly

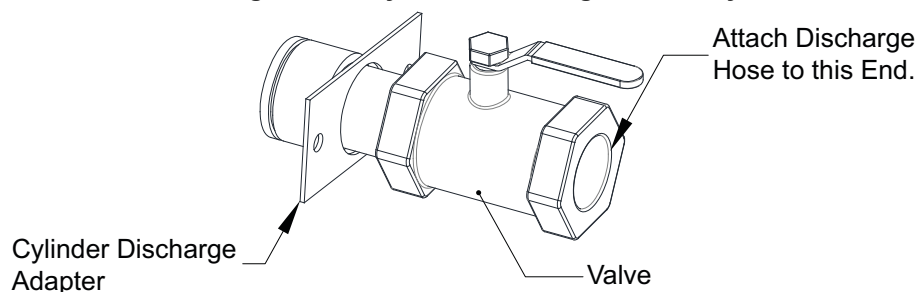

Rechecking the System

After the inspections and procedures described previously in this section, the fire-suppression system is ready to be fully checked out before installation of the replacement wet chemical cylinders.

1. Follow the system commissioning and test procedures outlined in **“START-UP/INSPECTION TEST PROCEDURE”** on page 59.
2. Be sure to check the system for all modes of operation.

Mobile Kitchen/Seasonal Shutdown

Figure 66 provides details on components that require attention when decommissioning/commissioning mobile kitchens or kitchens used for seasonal occasions.

When the kitchen is not in use for an extended period:

1. Verify incoming power to the hood is OFF or DISCONNECTED.
2. Disconnect the battery connection from the CORE Board at connector J1 located inside the control package. Alternatively, you may remove the fuse (5 amp blade fuse) from the battery connector kit.
3. Disconnect the PAK and SVA(s) from the tank(s).
4. Place the PAK and SVA(s) in the ship/test position. Install valve protection plate.

NOTE: If the space drops below -20°F, the tanks must be removed and stored in a conditioned space.

When starting the kitchen backup from an extended shutdown:

1. Verify incoming power to the hood is OFF or DISCONNECTED.
2. Verify the PAK and SVA(s) are in the set position.
3. Install the battery connection to the CORE Board at connector J1. If the fuse (5 amp blade fuse) is removed, install fuse to the connector kit at the batteries. If a replacement connector kit is required, order part number - CORECONKIT12. If replacement batteries are required (12V, 7AH, .250 terminals, AGM), order part number - PS-1270-F2 (must order two).
4. Check the pressure gauge is in the “green” range. If the pressure is low, refer to “**Adding Nitrogen to Tank(s)**” on page 68. If the tank(s) were removed for storage, install the tank(s).
5. Restore incoming power to the hood.
6. Remove the valve protection plate. Place the PAK and SVA(s) in the installed position. Refer to “**START-UP/ TEST PROCEDURE**” on page 57 to finish start-up.

Figure 66 - Actuator and Battery/Fuse Details

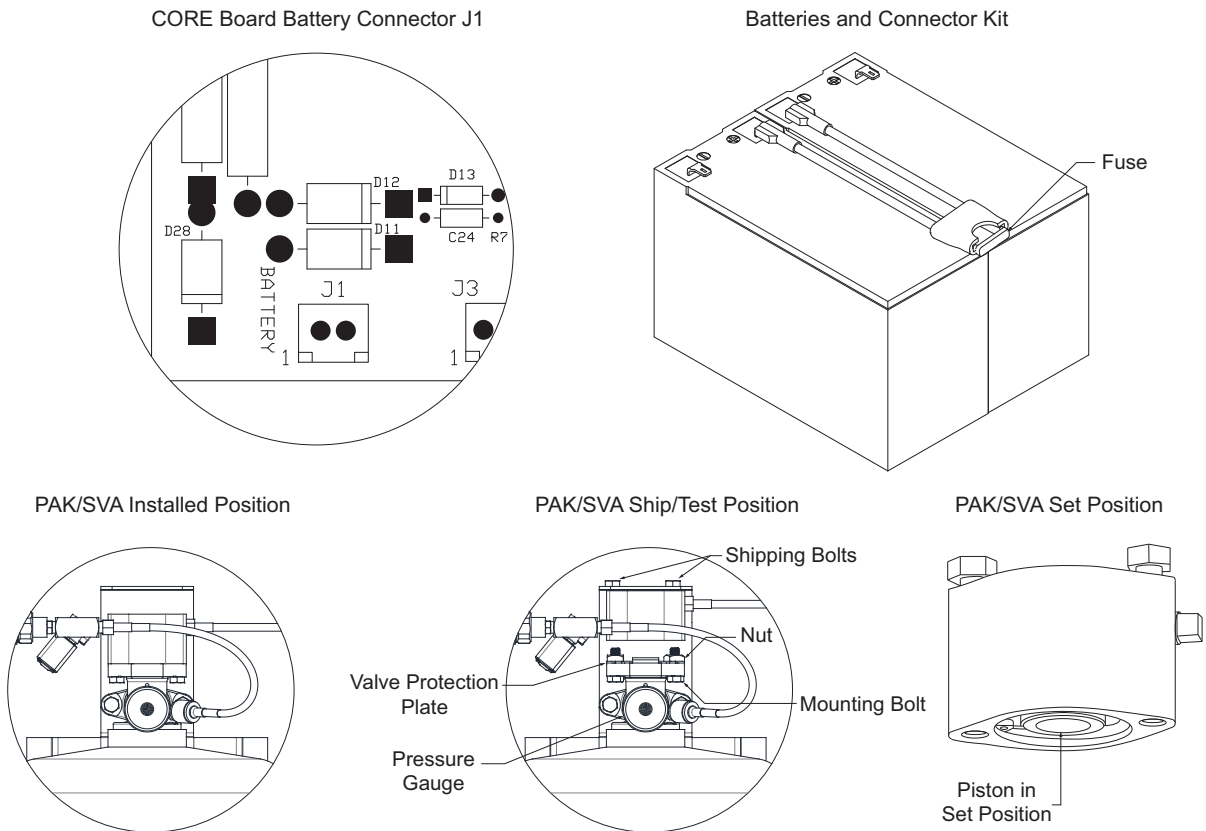

TANK FIRE SUPPRESSION SYSTEM PARTS

Table 21 - System Components

Description	Part Number
TFS Cylinder Assembly, Filled & Pressurized	87-300001-001
Bracket, TFS Cylinder	TFS-UCTANKBRACKET
Discharge Adapter	WK-283952-000
Discharge Adapter Tank Locking Plate	DATANKLOCK
O-Ring for Discharge Adapter	WK-108019-000
Primary Actuator Kit (PAK)	87-300030-001
O-ring 1/4" PAK Hose - Knurled Fitting	19020
O-ring 1/4" PAK Hose - Hex Fitting	PAKHOSEORING
Secondary Valve Actuator (SVA)	87-120042-001
Secondary Valve Actuator Hose 7"	87-120045-001
Secondary Valve Actuator Hose 24"	87-120045-002
Secondary Valve Actuator Hose 60"	87-120045-003
Cylinder Supervisory Pressure Switch	87-300040-001
Vent Limiting Orifice	12A06
Gas Shut-off Valve, 3/4" (ASCO)	8214235
Gas Shut-off Valve, 1" (ASCO)	8214250
Gas Shut-off Valve, 1-1/4" (ASCO)	8214265
Gas Shut-off Valve, 1-1/2" (ASCO)	8214275
Gas Shut-off Valve, 2" (ASCO)	8214280
Gas Shut-off Valve, 2-1/2" (ASCO)	8214290
Gas Shut-off Valve, 3" (ASCO)	8214240

Table 22 - Maintenance Components

Description	Part Number
Valve Protection Plate	WK-255096-000
Anti-Recoil Plate	WK-255681-000
Discharge Adapter Kit (includes mounting flange)	83-844908-000
Schrader Cap (used with valve for test and service ports)	87-300140-001
Schrader Valve (used for test and service ports)	87-300141-001
SVA bolts	87-300152-001
Balloons	ADRITE11IN
Bucket Support Bracket	BUCKSUP

Table 23 - Service Parts (not supplied with system)

Description	Part Number
TANK Fire Suppression Service Kit (Individual Parts Below)	TANK Fire Suppression-S-Kit
Fitting 1/4" Male to Male Thread Union	U24
Low-Loss Fitting 1/4" Straight Adapter Male to Female Thread	NABS
1/4" Refrigerant Test Hose, 36" Long	NHD1436
1/4" Refrigerant Test Hose, 60" Long	NHD1460
Nitrogen Service Cylinder (Ships empty)	HP20
Pressure Regulator	GEN450F
Inline Refrigerant Filter	C-032
Digital Pressure Gauge	Varies

