

# Standard and Modular/Recirculating Direct Fired Heaters Installation, Operation, and Maintenance Manual

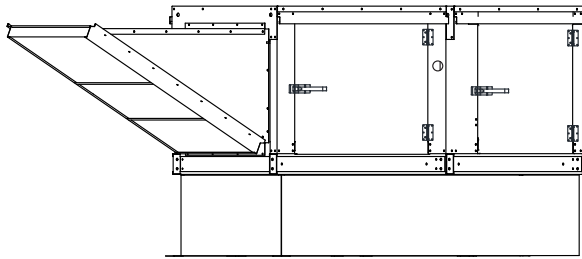

Modular Direct Fired Heater

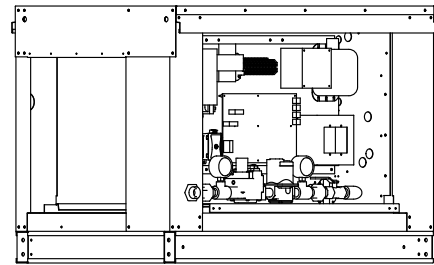

Direct Fired Heater

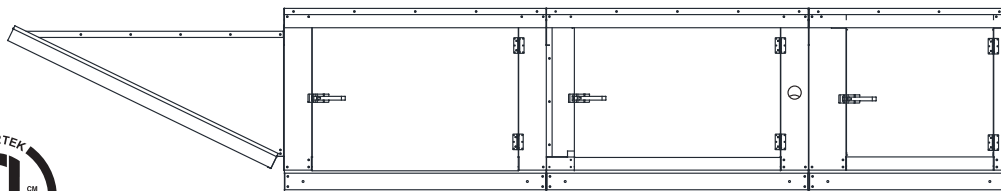

Modular Direct Fired Recirculating Heater

## **FOR YOUR SAFETY**

**IF YOU SMELL GAS: OPEN WINDOWS, DO NOT TOUCH ELECTRICAL SWITCHES, EXTINGUISH ANY OPEN FLAMES, IMMEDIATELY CALL YOUR GAS SUPPLIER.**

## **RECEIVING AND INSPECTION**

**Upon receiving unit, check for any interior and exterior damage. If damage is found, report it immediately to the carrier. Check that all accessory items are accounted for and free of damage.**

## **WARNING!**

**Improper installation, adjustment, alteration, service, or maintenance can cause property damage, injury, or death. Read the installation, operating, and maintenance instructions thoroughly before installing or servicing this equipment. ALWAYS disconnect power and gas before working on heater.**

**Save these instructions.** This document is the property of the owner of this equipment and is required for future maintenance. Leave this document with the owner when installation or service is complete.



## Table of Contents

<b>WARRANTY</b> .....	<b>4</b>	High Temperature Limit .....	60
<b>GENERAL INFORMATION</b> .....	<b>4</b>	Pilot Adjustment .....	60
Listing .....	4	Main Burner Adjustment (Maxitrol Valve) .....	61
Patents .....	4	Main Burner Adjustment (RTC Valve) .....	62
<b>INSTALLATION</b> .....	<b>5</b>	Final Start-up Procedure .....	63
Mechanical .....	5	Airflow Sensor .....	64
Site Preparation .....	5	Static Pressure Sensor Installation .....	65
Intake/Curb Assembly .....	7	<b>TROUBLESHOOTING</b> .....	<b>66</b>
Curb and Ductwork .....	8	Airflow Troubleshooting Chart .....	66
Roof Mount Installation .....	10	Burner Troubleshooting .....	67
Installation with Exhaust Fan .....	10	HMI Fault Codes .....	68
Duct Mount Installation .....	11	VFD Fault List .....	71
Indoor (Inline) Installation .....	11	Resetting Unit .....	71
Roof Mount Installation - Recirculation Unit .....	12	<b>MAINTENANCE</b> .....	<b>72</b>
Indoor (Inline) Installation Recirculation Unit .....	12	General Maintenance .....	72
Heat Module Add-On Installation .....	13	2 Weeks After Start-up .....	72
Gas .....	14	Every 3 Months .....	72
Gas Train .....	15	Yearly .....	72
Electrical .....	16	Burner Maintenance .....	73
Fan to Building Wiring Connection .....	17	Unit Filters .....	73
MUA Board Connectors .....	18	Emergency Shutdown of Unit .....	74
Duct Static Pressure Control .....	28	Prolonged Shutdown of Unit .....	74
Building Static Pressure Control .....	28	Start-Up Documentation .....	76
HMI and Remote Room Sensor Installation .....	29		
Temperature Control .....	30		
Maxitrol Modulating Valve .....	30		
RTC Modulating Valve .....	30		
Thermistor .....	30		
Thermistor Connected to HMI .....	30		
<b>OPERATION</b> .....	<b>31</b>		
Accessing Menu Configurations .....	31		
Remote (HMI) Control Panel .....	31		
HMI Notification Letters .....	31		
HMI Configuration Menu .....	32		
Communication .....	32		
Advanced Options .....	32		
Status .....	32		
About .....	32		
Scheduling .....	33		
Unit Options .....	34		
Communication Module (Optional) .....	34		
Building Signal Damper Control .....	34		
Electric Cabinet Heater .....	34		
Motorized Intake Damper .....	34		
Mixing Box Control Unit Options .....	34		
Menu Descriptions .....	35		
Electronically Commutated Motor Speed Control .....	49		
External PWM Signal .....	49		
Motorized Intake Damper .....	49		
Variable Frequency Drive (VFD) .....	49		
VFD Installation .....	50		
Input AC Power .....	50		
VFD Output Power .....	50		
VFD Programming .....	51		
ACTECH SMV VFD .....	52		
<b>START-UP OPERATION</b> .....	<b>53</b>		
Unit Start-up Procedure .....	53		
Pulley Adjustment .....	54		
Pulley Alignment/Proper Belt Tension .....	55		
Pulley Combination Chart .....	56		
Components .....	57		
Sequence of Operation .....	58		
Flame Safety Control .....	58		
Modulating Gas System .....	60		

## **WARRANTY**

This equipment is warranted to be free from defects in materials and workmanship, under normal use and service, for a period of 2-years from date of shipment. This warranty shall not apply if:

1. The equipment is not installed by a qualified installer per the MANUFACTURER'S installation instructions shipped with the product.
2. The equipment is not installed in accordance with Federal, State, and Local codes and regulations.
3. The equipment is misused, neglected, or not maintained per the MANUFACTURER'S maintenance instructions.
4. The equipment is not installed and operated within the limitations set forth in this manual.
5. The invoice is not paid within the terms of the sales agreement.

The MANUFACTURER shall not be liable for incidental and consequential losses and damages potentially attributable to malfunctioning equipment. Should any part of the equipment prove to be defective in material or workmanship within the 2-year warranty period, upon examination by the MANUFACTURER, such part will be repaired or replaced by MANUFACTURER at no charge. The BUYER shall pay all labor costs incurred in connection with such repair or replacement. Equipment shall not be returned without MANUFACTURER'S prior authorization, and all returned equipment shall be shipped by the BUYER, freight prepaid to a destination determined by the MANUFACTURER.

**NOTE: To receive warranty coverage for this product, copy and print out the "Start-Up Documentation" on page 76. Fill in all required details. Fax the page to 1-919-516-8710 or call 1-866-784-6900 for email information.**

## **GENERAL INFORMATION**

### **Listing**

This unit is ETL-listed to the American National Standard/CSA Standard for Gas Unit Heaters And Gas-Fired Duct Furnaces ANSI Z83.4, CSA 3.7.

The Safety Control Board is ETL-listed to standard UL 60730-2-9, UL 60730-1, CSA E60730-1, CSA E60730-2-9.

### **Patents**

This product may be covered by one or more of the following patent number(s): (United States) 6629523, or other U.S. and foreign patents pending.

## INSTALLATION

It is imperative that this unit is installed and operated with the designed airflow and electrical supply in accordance with this manual. If there are any questions about any items, please call the service department at **1-866-784-6900** for warranty and technical support issues.

### Mechanical

**WARNING: DO NOT RAISE UNIT BY THE INTAKE HOOD, BLOWER, MOTOR SHAFT, OR BEARINGS. USE ALL LIFTING LUGS PROVIDED WITH A SPREADER BAR OR SLING UNDER THE UNIT.**

#### Clearance

The top, back, and front surfaces of this heater may not be installed less than 6" from combustible materials. The heater base may be installed on combustible surfaces. Allow 24" minimum service clearance on both sides of this heater.

### Site Preparation

1. Provide clearance around installation site to safely rig and lift equipment into its final position (**Figure 1**). Supports must adequately support equipment. Refer to manufacturer's estimated weights.
2. Locate unit close to the space it will serve to reduce long, twisted duct runs.
3. Consider general service and installation space when locating unit.
4. Do not allow air intake to face prevailing winds. Support unit above ground or at roof level high enough to prevent precipitation from being drawn into its inlet. The inlet must also be located at least 10 feet away from any exhaust vents. The fan inlet shall be located in accordance with the applicable building code provisions for ventilation air.
5. All air to the heater must be ducted from the outdoors. Recirculation of room air is not permitted. If in doubt regarding the application, consult the manufacturer.
6. Recirculation of room air may be hazardous in the presence of:
  - Flammable solids, liquids, and gases
  - Explosive materials (e.g., grain dust, coal dust, gunpowder, etc.)
  - Substances which may become toxic when exposed to heat (e.g., refrigerants, aerosols, etc.)
7. Recirculation is not recommended in uninsulated buildings where outside temperatures fall below 32°F (0°C).
8. Excessive recirculation or insufficient ventilation air, which results in inadequate dilution of the combustion products generated by the heater, may create hazardous concentrations of carbon dioxide, carbon monoxide, nitrogen dioxide, and other combustion products in the heated space. Refer to **Table 1 on page 6** for ventilation requirements.

Figure 1 - Spreader Bar

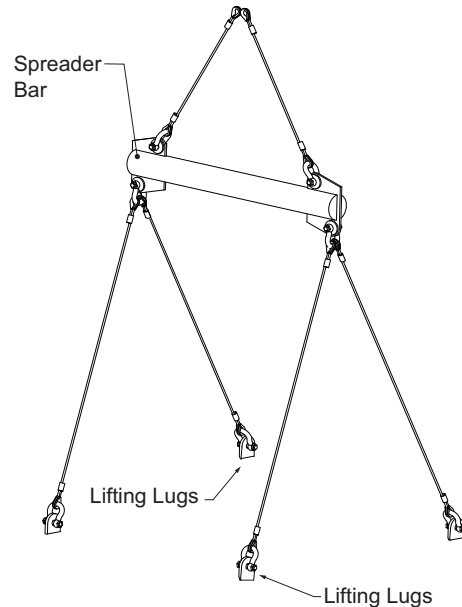

9. If gas fork trucks or other fossil fuel powered equipment are utilized in the conditioned area, additional ventilation requirements for the facility must be addressed separately.
10. If the heater utilizes room sensors for limiting room CO<sub>2</sub> concentration:
  - The CO<sub>2</sub> control set-point shall be no greater than the maximum allowable room concentration of 5000 ppm less the sensor's published accuracy tolerance. The control shall prevent the CO<sub>2</sub> concentration in room air from exceeding 5000 ppm.
  - A minimum of one sensor shall be installed per room served by the heater.
  - When a room area, served by a single heater, does not exceed 10,000 ft<sup>2</sup> (929 m<sup>2</sup>) and height does not exceed 20 ft. (6 m), a duct sensor may be installed in the return air opening of the heater.
  - Sensors shall be calibrated per the sensor manufacturer's recommended procedure and frequency or annually, whichever is more frequent.
  - Each heater shall require CO<sub>2</sub> sensor(s).
  - Sensors shall not be placed near sources of CO<sub>2</sub>.

**Table 1 - Minimum Ventilation Requirements for Heaters that Recirculate**

Minimum Ventilation Rate (as % of Total Air Throughput)									
%	5	10	15	20	25	30	40	50	60
Maximum Equivalent Temp. Rise Through Heat for CO <sub>2</sub> °F (°C)									
Natural Gas	12.2 (6.8)	24.5 (13.6)	36.7 (20.4)	49.0 (27.2)	61.2 (34.0)	73.5 (40.8)	98.0 (54.4)	122.5 (68.0)	146.9 (81.6)
Propane Gas	10.6 (5.9)	21.1 (11.7)	31.7 (17.6)	42.2 (23.5)	52.8 (29.3)	63.4 (35.2)	84.5 (46.9)	105.6 (58.7)	126.7 (70.4)

## Intake/Curb Assembly

Intakes and curbs (**Figure 2**) are shipped on a separate skid. Upon unit arrival, perform the following steps to assemble the unit.

1. Apply weather-proof gasketing to the curb. Apply silicone or weather-proof gasketing to the backside of the flanges on the intake hood or V-bank intake.
2. Secure the flanges of the intake hood to the unit with the supplied sheet metal screws.
3. Use caulk on the outside of the screws to prevent water leaks.
4. If the unit is a modular unit with a V-bank or evaporative cooler section, the V-bank or evaporative cooler will bolt to the heater with the bolts provided.
5. Slide the filters down the filter track.

**Figure 2 - Intake and Curb Assembly**

Direct Fired

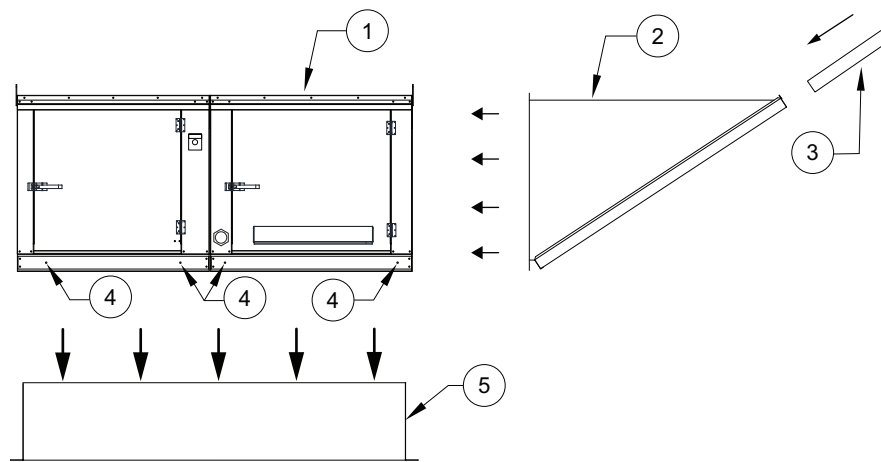

Direct Fired Recirc

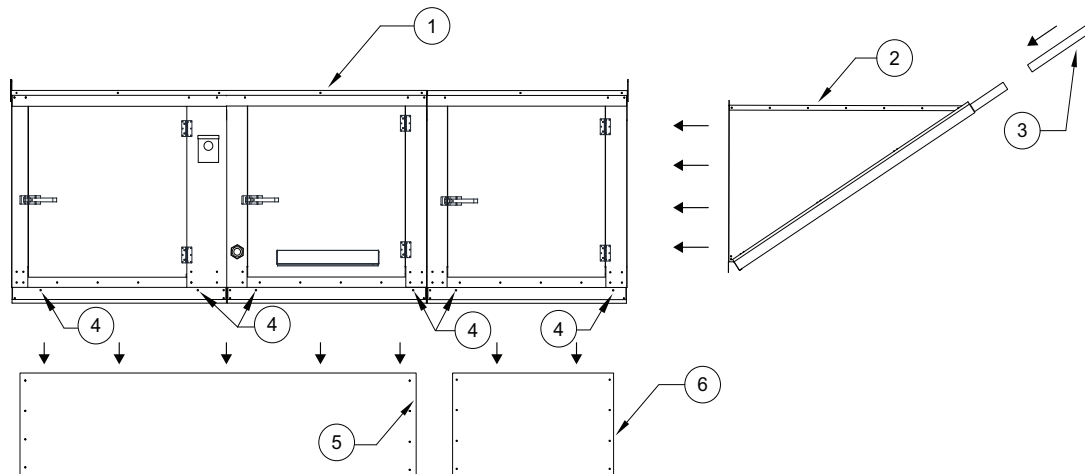

- |                     |  |
|---------------------|--|
| 1. Unit             | 4. Unit to Curb Hardware Mounting Location |
| 2. Intake Housing   | 5. Curb                                    |
| 3. Intake Filter(s) | 6. Mixing Box Curb                         |

## Curb and Ductwork

This fan was specified for a specific CFM and static pressure. The ductwork attached to this unit will significantly affect airflow performance. When using rectangular ductwork, elbows must be radius throat, radius back with turning vanes. Flexible ductwork and square elbows should not be used. Any transitions and/or turns in the ductwork near the fan outlet will cause system effect. System effect will drastically increase the static pressure and reduce airflow.

- **Table 3 on page 9** displays the minimum fan outlet duct sizes and straight lengths required for optimal fan performance. **Table 2** displays recommended return ductwork sizes for recirculating units.
- Do not use the unit to support ductwork in any way. This may cause damage to the unit.
- **Follow SMACNA guides and manufacturer's requirements for the remaining duct run.** Fans designed for rooftop installation should be installed on a prefabricated or factory-built roof curb.
- Follow curb manufacturer's instructions for proper curb installation.
- The unit should be installed on a curb and/or rail that meets local code height requirements.
- Make sure the duct connection and fan outlet are properly aligned and sealed.
- Secure fan to curb through vertical portion of the ventilator base assembly flange. Use a minimum of eight (8) lug screws, anchor bolts, or other suitable fasteners (not furnished). Shims may be required depending upon curb installation and roofing material.
- Verify all fasteners are secure. **Figure 3** through **Figure 8** show different mechanical installations.
- Adequate building relief shall be provided so as not to over pressurize the building when the heating system is operating at its rated capacity. This can be accomplished by taking into account, through standard engineering methods, the structure's designed infiltration rate; by providing properly-sized relief openings; or by interlocking a powered exhaust system; or by a combination of these methods.
- Heaters installed with intake ductwork must be purged to replace at least four air changes of the volume of the intake duct.
- If the failure or malfunction of this heater creates a hazard to other fuel-burning equipment in the building (e.g., when the heater is providing makeup air to a boiler room), the unit is to be interlocked to open inlet air dampers or other such devices.
- On outdoor installations, it is recommended that the discharge duct be insulated to prevent condensation during the "OFF" cycle in cold weather.
- Flexible connectors should be used on all ductwork connections. Vibration isolators are optional and can be supplied in the loose parts package.
- Units that are installed in airplane hangars should be installed in accordance with the Standard for Aircraft Hangars, ANSI/NFPA 409. Units that are to be installed in public garages should be installed in accordance with the Standard for Parking Structures, ANSI/NFPA 88A, or the Standard for Repair Garages, ANSI/NFPA 88B, and with CAN/CGA B149 Installation Codes.

**Table 2 - Recommended Return Ductwork Sizes**

Mixing Box	Duct Size (Inches)
1	19 x 15
2	25 x 24
3	31 x 29
4	37 x 34
5	44 x 44



**Table 3 - Required Supply Ductwork**

<b>Blower Size (Inches)</b>	<b>Discharge</b>	<b>Duct Size</b>	<b>Straight Duct Length</b>
10	Side	14" x 14"	48"
	Up/Down		
15D, 16Z, 18Z	Side	20" x 20"	72"
	Up/Down	14" x 14"	48"
12	Side	16" x 16"	54"
	Up/Down		
15	Side	20" x 20"	72"
	Up/Down		
20D, 20Z, 22Z	Side	26" x 26"	108"
	Up/Down	20" x 20"	72"
18	Side	24" x 24"	86"
	Up/Down		
24D, 25Z	Side	30" x 30"	108"
	Up/Down	24" x 24"	86"
20	Side	26" x 26"	108"
	Up/Down		
30D, 28Z	Side	32" x 32"	168"
	Up/Down	26" x 26"	108"
25	Side	32" x 32"	168"
	Up/Down		
36D	Side	36" x 36"	189"
	Up/Down	32" x 32"	168"

**WARNING!**

**Failure to properly size ductwork may cause system effects and reduce the performance of the equipment.**

## Roof Mount Installation

Note: Refer to submittal drawings for specific unit dimensions.

Figure 3 - Roof Mount Details

1. Discharge Opening
2. Curb Outer Wall
3. Flex Conduit Located in Curb Area for Field Wiring
4. Intake Housing
5. Lifting Lugs
6. Direct Fired Module
7. Service Disconnect Switch
8. Blower/Motor Access Door
9. Curb
10. Control Drop
11. Motor Drop
12. Unit to Curb Hardware Mounting Location
13. Gas Connection

Max. Roof Opening 2" Smaller than Curb Outside Dimension.

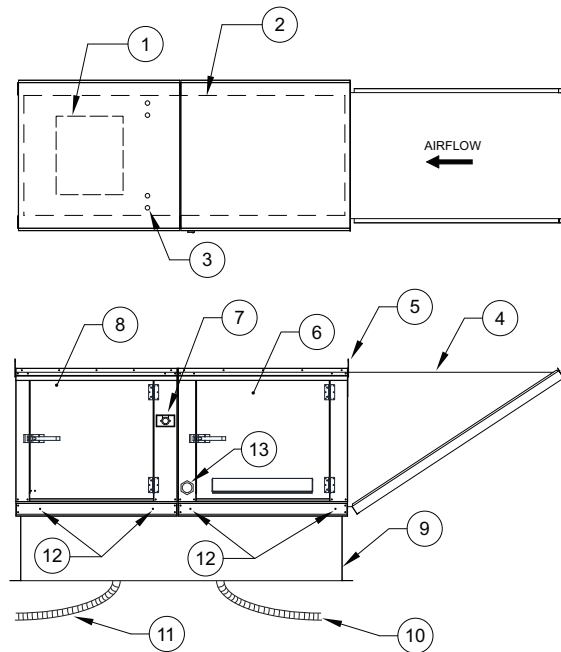

## Installation with Exhaust Fan

Note: Refer to submittal drawings for specific unit dimensions.

Figure 4 - Exhaust Fan Details

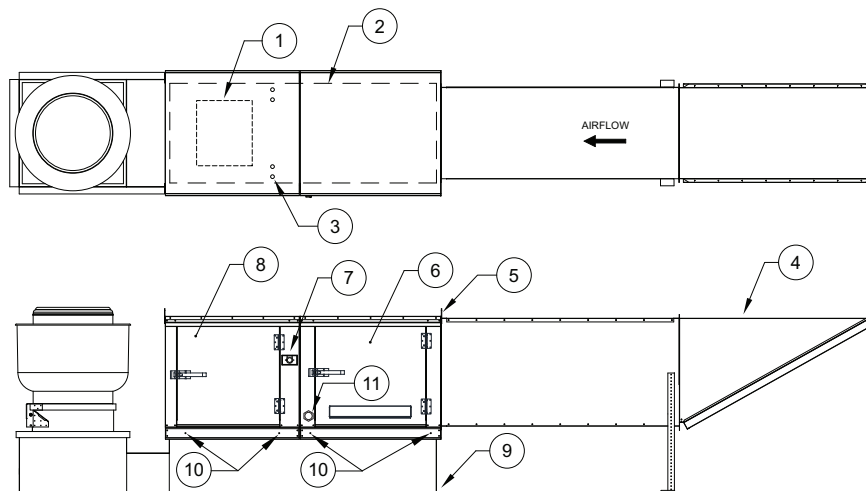

- |   |                              |   |
|---|------------------------------|---|
| 1. Discharge Opening                                  | 5. Lifting Lugs              | 9. Curb with Support Legs or Rail           |
| 2. Curb Outer Wall                                    | 6. Direct Fired Module       | 10. Unit to Curb Hardware Mounting Location |
| 3. Flex Conduit Located in Curb Area for Field Wiring | 7. Service Disconnect Switch | 11. Gas Connection                          |
| 4. Intake Housing                                     | 8. Blower/Motor Access Door  |   |

Max. Roof Opening 2" Smaller than Curb Outside Dimension.

## Duct Mount Installation

Note: Refer to submittal drawings for specific unit dimensions.

Figure 5 - Duct Mount Details

1. Control/Valve Access Door
2. Gas Connection
3. Optional Unistrut Base
4. Lifting Lugs

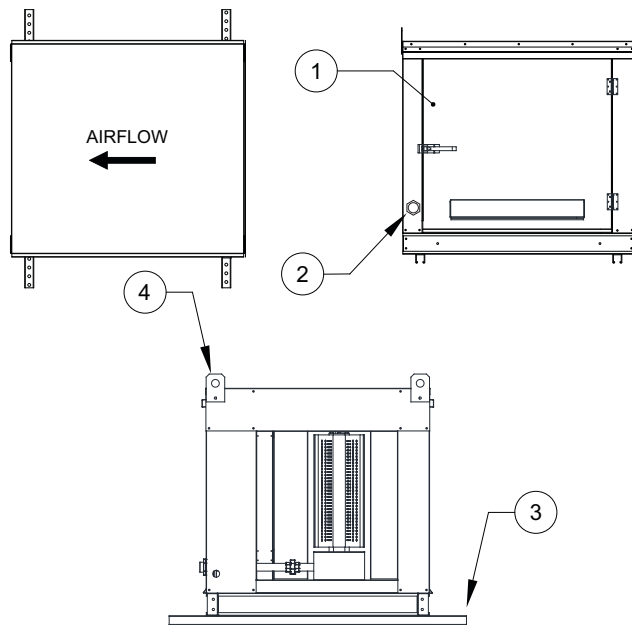

## Indoor (Inline) Installation

Note: Refer to submittal drawings for specific unit dimensions.

Figure 6 - Indoor Installation Details

1. Flex Conduit for Field Wiring
2. Optional Unistrut Base
3. Lifting Lugs
4. Control/Filter Access Door
5. Control/Valve Access Door
6. Gas Connection
7. Blower/Motor Access Door
8. Service Disconnect Switch

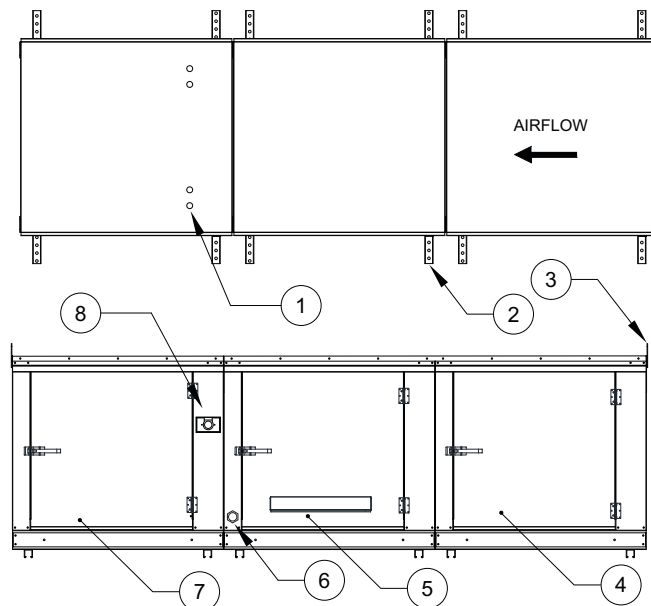

## Roof Mount Installation - Recirculation Unit

Note: Refer to submittal drawings for specific unit dimensions.

Figure 7 - Roof Mount Details

1. Discharge Opening
2. Curb(s) Outer Wall
3. Return Damper
4. Flex Conduit for Field Wiring
5. Blower/Motor Access Door
6. Service Disconnect Switch
7. Direct Fired Module
8. Optional Filters
9. Intake Damper
10. Lifting Lugs
11. Intake Filter
12. Control Drop
13. Motor Drop
14. Unit to Curb Hardware Mounting Location
15. Gas Connection

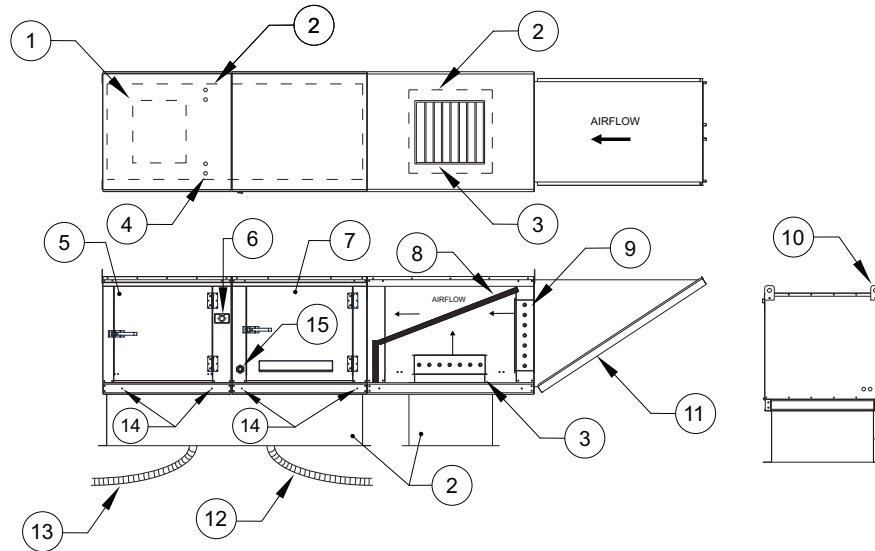

## Indoor (Inline) Installation Recirculation Unit

Note: Refer to submittal drawings for specific unit dimensions.

Figure 8 - Indoor Installation Details

1. Flex Conduit for Field Wiring
2. Optional Filters
3. Return Damper
4. Intake Damper
5. Direct Fired Module
6. Blower/Motor Access Door
7. Service Disconnect Switch
8. Lifting Lugs
9. Optional Uni-Strut Base

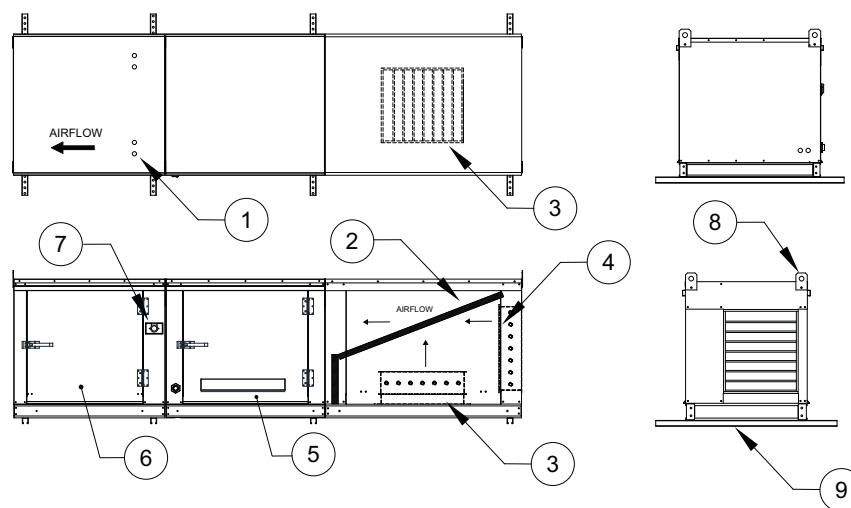

## Heat Module Add-On Installation

Modular heat units (**Figure 9**) that are ordered to provide heat onto an existing blower only application require field mechanical and wiring installation.

1. Remove existing intake housing and lifting lugs from the blower section intake side.
2. Attach heat module to blower intake using the provided sheet metal screws and bolts. Tighten screws and bolts to compress the gasket between the heat module and the blower module.
3. Support and level the end of the heat module (opposite end of the blower) with the provided equipment legs/rails.
4. Attach the intake housing to the intake side of the heater module.
5. Drill a hole in the discharge of the blower large enough to insert the discharge control sensor (if provided). Install the sensor through the hole.
6. Wire the sensor and coil as indicated on the supplied wiring schematic. Route all wiring through metal conduit.
7. After the add-on installation is complete, refer to “**Unit Start-up Procedure**” on page 53.

**Figure 9 - Heat Module**

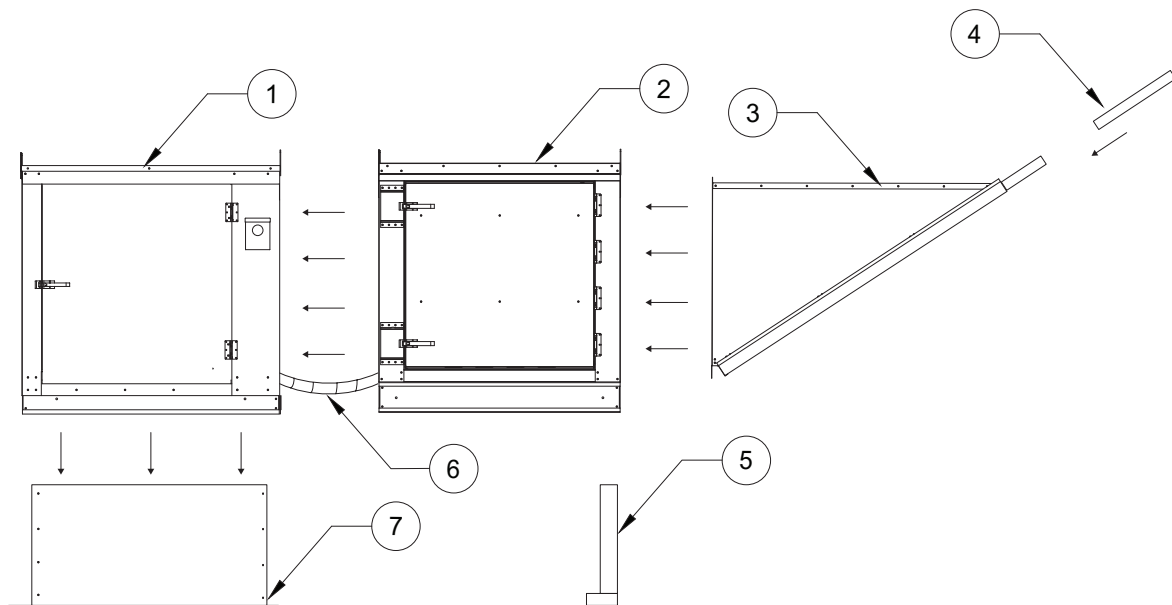

- |                        |                   |
|------------------------|-------------------|
| 1. Blower              | 5. Equipment Legs |
| 2. Direct Fired Module | 6. Conduit        |
| 3. Intake Housing      | 7. Curb           |
| 4. Filters             |                   |

## Gas

Installation of gas piping must conform with local building codes, or in the absence of local codes to the National Fuel Gas Code, ANSI Z223.1 (NFPA 54) – latest edition. In Canada, installation must be in accordance with CAN/CGA-B149.1 for natural gas units and CAN/CGA-B149.2 for propane units.

**WARNING: INLET GAS PRESSURE MUST NOT EXCEED PRESSURE INDICATED ON NAMEPLATE. SEE UNIT NAMEPLATE FOR PROPER GAS SUPPLY PRESSURE AND GAS TYPE.**

1. Always **disconnect power** before working on or near a heater. Lock and tag the disconnect switch or breaker to prevent accidental power-up.
2. Piping to the unit should conform to local and national requirements for type and volume of gas handled, and pressure drop allowed in the line. Refer to the Gas Engineer's Handbook for gas line capacities.
3. The incoming pipe near the heater should be sized to match the connection on the outside of the unit. Unit inlet sizes are shown in **Table 4 on page 15**. The unit requires a steady supply of gas at all times, avoid multiple taps in the gas supply line.
4. Install a ground joint union with brass seat and a manual shut-off valve external to the unit casing. Install shut-off valve adjacent to the unit for emergency shut-off and easy servicing of controls. Refer to **Figure 10 on page 15**.
5. Provide a sediment trap, as shown in **Figure 10**, before each unit and where low spots in the pipeline cannot be avoided.
6. Clean out the gas line to remove debris before making connections. Purge gas line to remove air before attempting to start unit. Purging air from gas lines should be performed as described in ANSI Z223.1-latest edition "National Fuel Gas Code," or in Canada as described in CAN/CGA-B149.
7. All field gas piping must be pressure/leak tested before unit operation. Use a non-corrosive bubble forming solution or equivalent for leak testing. The heater and its individual shut-off valve must be disconnected from the gas supply piping system during any pressure testing of that system at test pressures in excess of 1/2 psi.
8. This unit requires the gas pressure to be within the unit's minimum and maximum gas pressure ratings. If the pressure is greater than the maximum, the internal valve components will be damaged. If the pressure is below the minimum, the heater will not perform to specifications. Refer to **Table 4 on page 15** for gas pressure ratings.

### **NOTICE**

**Refer to the heater's rating plate for determining gas supply pressures and requirements.**

## Gas Train

A strainer must be installed to prevent debris from entering the gas train. Only use new piping. Properly ream and clean metal burrs. Proper care is needed to ensure that the gas flow is in the same direction as indicated on the strainer. Do not over-tighten pipe connections. Use pipe dope on male threads only. Install a drip leg in the gas line in accordance with the Authority Having Jurisdiction (AHJ) guidelines.

**Figure 10 - Gas Connection Diagram**

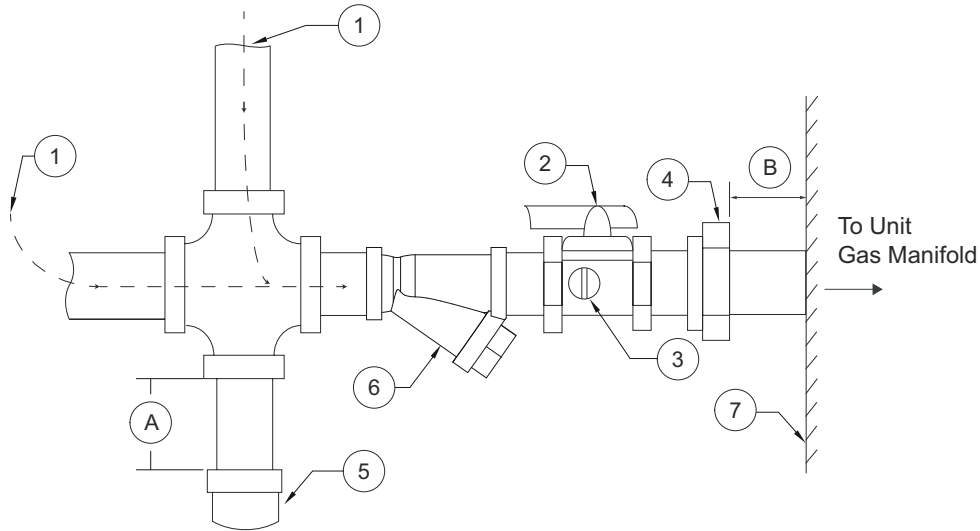

- |   |                         |
|---|-------------------------|
| 1. Gas Supply Line Connection             | 6. Strainer             |
| 2. Manual Gas Shut-off Valve              | 7. Unit                 |
| 3. Plugged 1/8" NPT Test Gauge Connection | A. Minimum Depth = 6"   |
| 4. Ground Joint Union with Brass Seat     | B. Maximum Length = 12" |
| 5. Sediment Trap                          |                         |

Proper clearance must be provided in order to service the strainer. A minimum of a 4" clearance distance must be provided at the base of the strainer.

**Table 4 - Gas Train Details**

Pressure Type	Gas Pressure
Size 1-3 Inlet Pressure	7 - 14 Inches WC
Size 4-5 Inlet Pressure	7 Inches WC - 5 psi
Maximum Manifold Pressure - Propane (LP)	2.5 Inches WC Maximum
Maximum Manifold Pressure - Natural Gas	5 Inches WC Maximum
Strainer	Size
Size 1 = 4417K64	3/4"
Size 2 and Size 3 = 4417K65	1"
Size 4 = 4417K66	1-1/4"
Size 5 = 4417K67	1-1/2"

## Electrical

**WARNING!**

**Disconnect power before installing or servicing unit. High voltage electrical input is needed for this equipment. A qualified electrician should perform this work.**

Before connecting power to the heater, read and understand the entire section of this document. As-built wiring diagrams are furnished with each unit by the factory. The diagrams are attached to the control module's door or provided with paperwork packet.

Electrical wiring (**Table 5**) and connections must be made in accordance with local ordinances and the National Electric Code, ANSI/NFPA 70. Verify the voltage and phase of the power supply, and the wire amperage capacity is in accordance with the unit nameplate. For additional safety information, refer to AMCA publication 410-96, *Recommended Safety Practices for Users and Installers of Industrial and Commercial Fans*.

1. **Always disconnect power before working on or near this equipment. Lock and tag the disconnect switch and/or breaker to prevent accidental power-up.**
2. An electrical drop containing the line voltage power wiring is shipped with every unit. The electrical drop should be brought through one of the conduit openings located in the base of the unit (**Figure 3 on page 10**), run through the curb, and connected to a junction box inside the building.
3. A dedicated branch circuit should supply the motor circuit with short circuit protection according to the National Electric Code. This dedicated branch should run to the junction box.
4. Verify that the power source is compatible with the requirements of your equipment. The nameplate identifies the **proper phase and voltage** of the equipment.
5. Units shipped with a remote HMI will require a second drop through the base of the unit. It is important to route the motor wires in a separate conduit from the HMI wiring. Refer to **Figure 3 (Direct Fired)/Figure 7 (Recirc) on page 12**.
6. Before connecting the unit to the building's power source, verify that the power source wiring is de-energized. Refer to **"Fan to Building Wiring Connection" on page 17**.
7. Secure the power cable to prevent contact with sharp objects. Verify ground connection is secured.
8. Do not kink power cable and never allow the cable to encounter oil, grease, hot surfaces, or chemicals.
9. Before powering up the unit, that the fan rotates freely. Make sure that the interior of the unit is free of loose debris or shipping materials.
10. If any of the original wire supplied with the unit must be replaced, it must be replaced with type THHN wire or equivalent.

**Table 5 - Copper Wire Ampacity**

Wire Size AWG	Maximum Amps
14	15
12	20
10	30
8	50
6	65
4	85
3	100
2	115
1	130



# Fan to Building Wiring Connection

## Figure 11 - Wiring Connection Details

### Single Point Connection

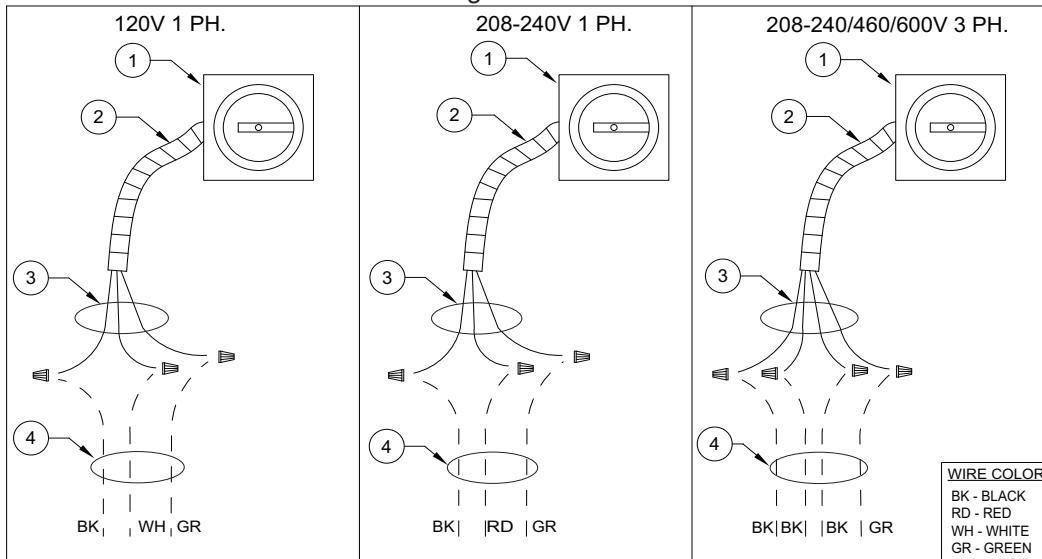

1. Disconnect Switch
2. Galflex Conduit (In Unit)
3. Factory Wiring
4. Field Supplied Wiring - From building power or pre-wired control panel.

### 120V Optional

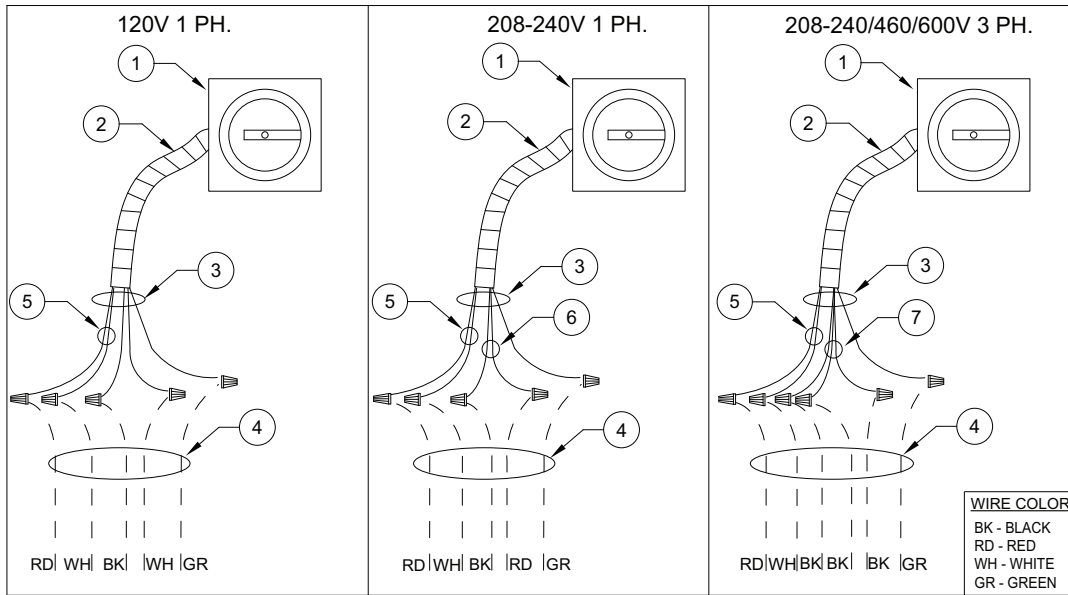

1. Disconnect Switch
2. Galflex Conduit (In Unit)
3. Factory Wiring
4. Field Supplied Wiring - From building power or pre-wired control panel.
5. 120V Single Phase Standing Power
6. 208-240 Single Phase
7. Three Phase

# MUA Board Connectors

The Make-up Air (MUA) Board (Figure 12) is located in the main control cabinet.

## Figure 12 - Make-Up Air Board

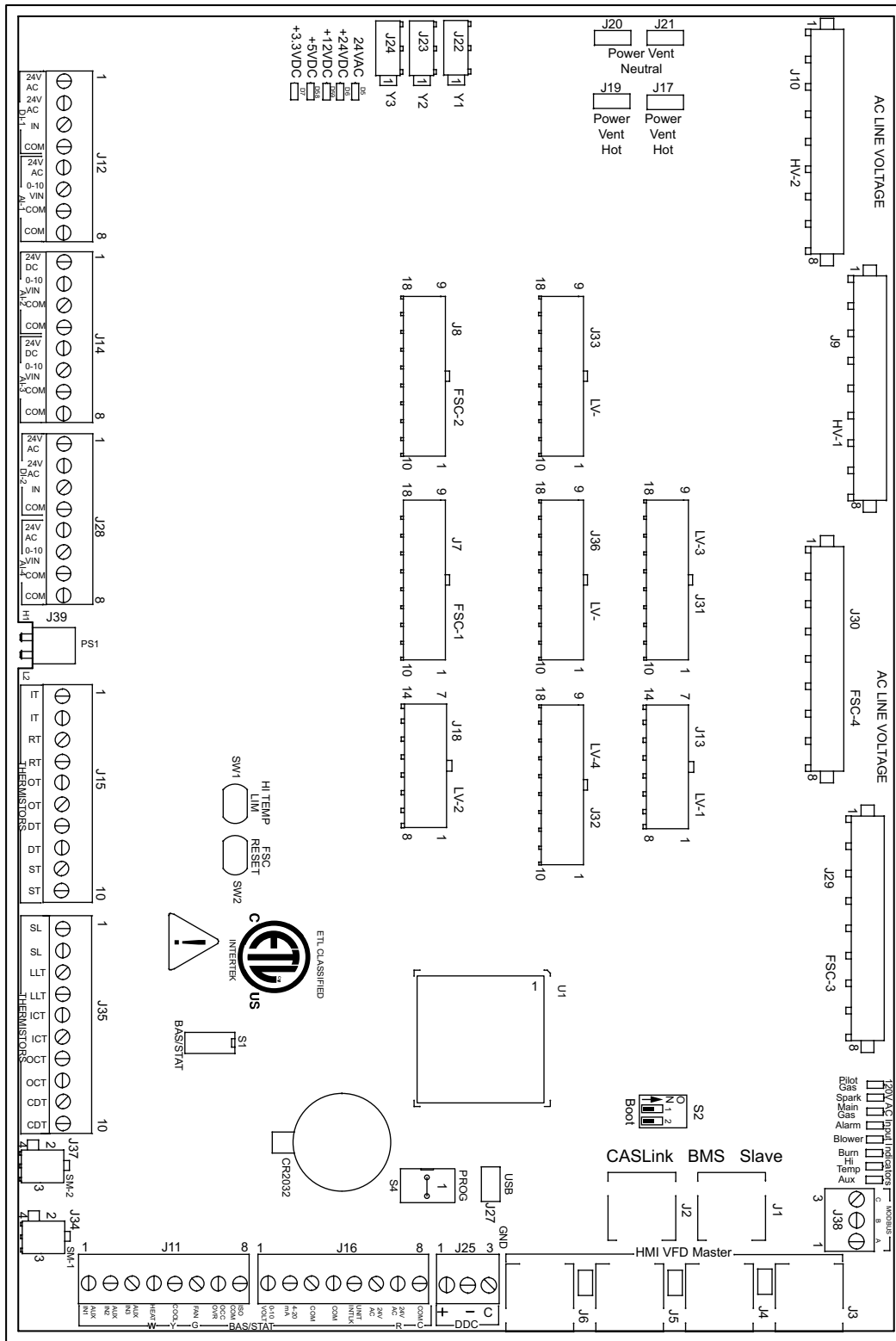

**Note: Some connections may not be used dependent on system configurations.**

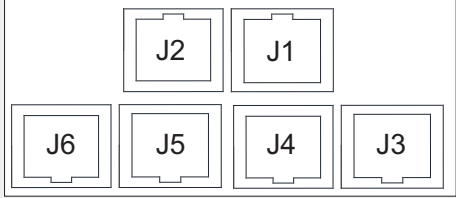
<p>RJ45 connectors.  <b>Connector J1 and J2</b> are associated with BMS.  <b>Connector J3 through J6</b> are interchangeable and may be used to connect to an HMI or VFD.</p>	
<p><b>J1</b> - CASLink/Slave  <b>J2</b> - CASLink/Slave  <b>J3</b> - HMI/VFD/Master</p>	<p><b>J4</b> - HMI/VFD/Master  <b>J5</b> - HMI/VFD/Master  <b>J6</b> - HMI/VFD/Master</p>

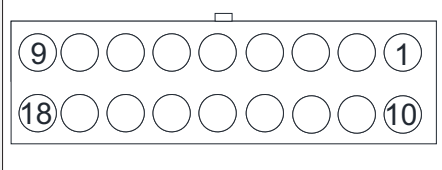
<p><b>Connector J7</b> contains inputs and outputs for the Flame Safety Controller (FSC)</p>	
<p><b>Pin 1</b> - N/A  <b>Pin 2</b> - 24VAC Pilot Valve  <b>Pin 3 through Pin 8</b> - N/A  <b>Pin 9</b> - 24VAC Common to Main/Pilot Gas Valve</p>	<p><b>Pin 10 through Pin 18</b> - N/A</p>

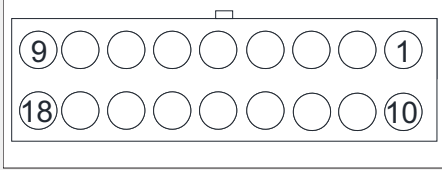
<p><b>Connector J8</b> contains inputs and outputs for the Flame Safety Controller (FSC)  <b>NOTE: Connector J8 only for Compact Models</b></p>	
<p><b>Pin 1</b> - N/A  <b>Pin 2</b> - 24VAC Pilot Valve  <b>Pin 3 through Pin 8</b> - N/A  <b>Pin 9</b> - 24VAC Common to Main/Pilot Gas Valve</p>	<p><b>Pin 10 through Pin 18</b> - N/A</p>

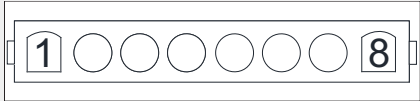
<p><b>Connector J9</b> contains 120V AC connections</p>	
<p><b>Pin 1</b> - 120VAC Main Input  <b>Pin 2</b> - 120VAC Input from Discharge Damper End Switch  <b>Pin 3</b> - 120VAC Input from Fire Micro-Switch  <b>Pin 4</b> - 120VAC Output to Intake/Discharge Damper Actuator</p>	<p><b>Pin 5</b> - 120VAC Input from Intake Damper End Switch  <b>Pin 6</b> - N/A  <b>Pin 7</b> - 120VAC Output to Cabinet Heater  <b>Pin 8</b> - 120VAC Neutral</p>

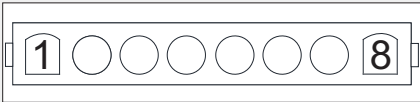
<p><b>Connector J10</b> contains 120V AC connections</p>	
<p><b>Pin 1</b> - 120VAC Input from Evap Cooler Pressure Switch  <b>Pin 2</b> - 120VAC Input from Evap Cooler Float Switch  <b>Pin 3</b> - 120VAC Output to Evap Cooler Water Solenoid  <b>Pin 4</b> - 120VAC Output to Evap Cooler 3-way Drain Valve</p>	<p><b>Pin 5</b> - 120VAC Input from Supply Overload  <b>Pin 6</b> - 120VAC Output to Supply Starter Coil  <b>Pin 7</b> - 120VAC Output to Exhaust Starter Coil  <b>Pin 8</b> - 120VAC Input from Exhaust Overload</p>

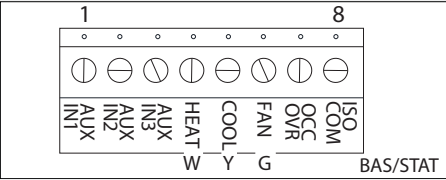
<p><b>Connector J11</b> contains low voltage screw terminal connections</p>	
<p><b>Pin 1</b> - 24VAC Auxiliary Input/Purge Mode  <b>Pin 2</b> - 24VAC Auxiliary Input  <b>Pin 3</b> - 24VAC Auxiliary Input  <b>Pin 4</b> - 24VAC Call for Heat Input/Burner Interlock</p>	<p><b>Pin 5</b> - 24VAC Call for Cooling Input/AC Interlock  <b>Pin 6</b> - 24VAC Call for Blower Input  <b>Pin 7</b> - 24VAC Occupied Override Input  <b>Pin 8</b> - 24VAC Isolated Common</p>

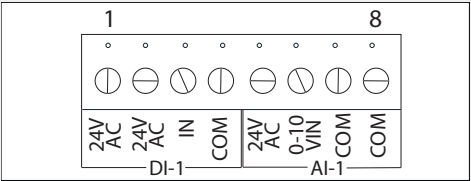
<p><b>Connector J12</b> contains low voltage screw terminal connections</p>	
<p><b>Pin 1</b> - 24VAC Output to Smoke Detector  <b>Pin 2</b> - 24VAC Output to Smoke Detector  <b>Pin 3</b> - 24VAC Digital Input from Smoke Detector  <b>Pin 4</b> - 24VAC Common to Smoke Detector</p>	<p><b>Pin 5</b> - 24VAC Output to Air Quality Sensor  <b>Pin 6</b> - 0-10V Analog Input from Air Quality Sensor  <b>Pin 7</b> - 24VAC Common to Air Quality Sensor  <b>Pin 8</b> - 24VAC Common to Air Quality Sensor</p>

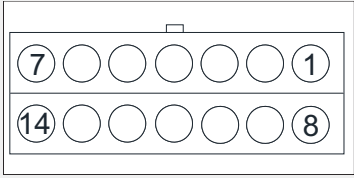
<p><b>Connector J13</b> contains low voltage connections</p>	
<p><b>Pin 1</b> - N/A  <b>Pin 2</b> - PWM + Output for Supply ECM  <b>Pin 3</b> - 24VAC Output for Low Gas Pressure Switch  <b>Pin 4</b> - 24VAC Output for High Gas Pressure Switch  <b>Pin 5</b> - 24VAC Output for Clogged Filter Switch  <b>Pin 6</b> - 24VAC Output for Low Airflow  <b>Pin 7</b> - 24VAC Input for Board Power</p>	<p><b>Pin 8</b> - N/A  <b>Pin 9</b> - PWM Output for Supply ECM  <b>Pin 10</b> - 24VAC Input from Low Gas Pressure Switch  <b>Pin 11</b> - 24VAC Input from High Gas Pressure Switch  <b>Pin 12</b> - 24VAC Input from Clogged Filter Switch  <b>Pin 13</b> - 24VAC Input from Low Air Pressure Switch  <b>Pin 14</b> - 24VAC for Board Power</p>

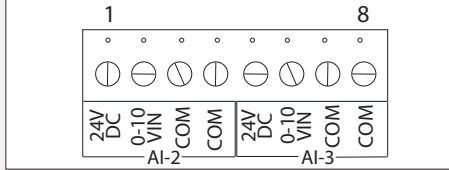
<p><b>Connector J14</b> contains screw terminal connections</p>	
<p><b>Pin 1</b> - 24VAC Output to Humidity Sensor  <b>Pin 2</b> - 0-10VDC Analog Input from Humidity Sensor  <b>Pin 3</b> - 24VAC Common to Humidity Sensor  <b>Pin 4</b> - 24VAC Common to Humidity Sensor</p>	<p><b>Pin 5</b> - 24VAC Output to Humidity Sensor  <b>Pin 6</b> - 0-10VDC Analog Input Humidity Sensor  <b>Pin 7</b> - 24VAC Common Humidity Sensor  <b>Pin 8</b> - 24VAC Common to Humidity Sensor</p>

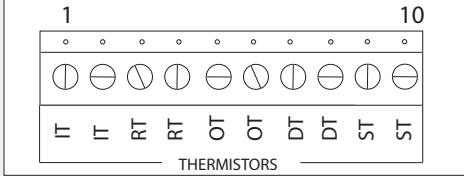
<p><b>Connector J15</b> contains low voltage connections</p>	
<p><b>Pin 1</b> - Intake Temperature Thermistor Input  <b>Pin 2</b> - Intake Temperature Thermistor Input  <b>Pin 3</b> - Return Temperature Thermistor Input  <b>Pin 4</b> - Return Temperature Thermistor Input  <b>Pin 5</b> - Outdoor Temperature Thermistor Input</p>	<p><b>Pin 6</b> - Outdoor Temperature Thermistor Input  <b>Pin 7</b> - Discharge Temperature Thermistor Input  <b>Pin 8</b> - Discharge Temperature Thermistor Input  <b>Pin 9</b> - Space Temperature Thermistor Input  <b>Pin 10</b> - Space Temperature Thermistor Input</p>

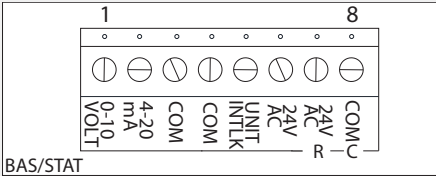
<p><b>Connector J16</b> contains low voltage screw terminal connections</p>	
<p><b>Pin 1</b> - 0-10VDC Analog Input for Heat Modulation/ Pressure Sensor  <b>Pin 2</b> - 4-20 mA Analog Input for Heat Modulation/ Pressure Sensor  <b>Pin 3</b> - 24VAC Common  <b>Pin 4</b> - 24VAC Common</p>	<p><b>Pin 5</b> - 24VAC Unit Interlock Input  <b>Pin 6</b> - 24VAC Output (Stat)  <b>Pin 7</b> - 24VAC Output (R)  <b>Pin 8</b> - 24VAC Common</p>

**NOTE:** Connector J17 is grouped with connectors J-19 through J-21

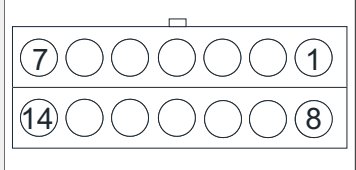
<p><b>Connector J18</b> contains low voltage connections</p>	
<p><b>Pin 1</b> - 24VDC + Output  <b>Pin 2</b> - 0-10VDC Analog Output for Mixing Box Actuator  <b>Pin 3</b> - 0-10VDC Analog Output for Bypass Damper  <b>Pin 4</b> - 24VAC Output for DX Float Switch  <b>Pin 5</b> - 24VAC Output for Door Interlock  <b>Pin 6</b> - 24VAC Warm Liquid Bypass Output  <b>Pin 7</b> - 24VAC for Damper Actuator</p>	<p><b>Pin 8</b> - 24VDC - Common  <b>Pin 9</b> - Common for Mixing Box Actuator  <b>Pin 10</b> - Common for Bypass Damper  <b>Pin 11</b> - 24VAC Input from DX Float Switch  <b>Pin 12</b> - 24VAC Input from Door Interlock  <b>Pin 13</b> - 24VAC Warm Liquid Bypass Output Common  <b>Pin 14</b> - 24VAC for Damper Actuator</p>

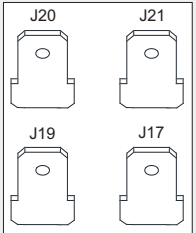
<p><b>Connector J17</b> - N/A  <b>Connector J19</b> - N/A  <b>Connector J20</b> - N/A  <b>Connector J21</b> - N/A</p>	
---	---

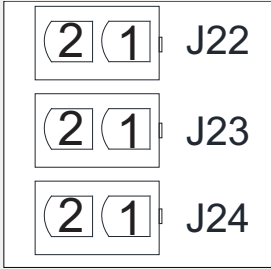
<p><b>Connector J22</b> (Y1) Condenser 1  <b>Connector J23</b> (Y2) Condenser 2  <b>Connector J24</b> (Y3) Condenser 3</p>	
<p><b>J22 Pin 1</b> - 24VAC Output to Condenser 1  <b>J22 Pin 2</b> - 24VAC Common to Condenser 1  <b>J23 Pin 1</b> - 24VAC Output to Condenser 2</p>	<p><b>J23 Pin 2</b> - 24VAC Common to Condenser 2  <b>J24 Pin 1</b> - 24VAC Output to Condenser 3  <b>J24 Pin 2</b> - 24VAC Common to Condenser 3</p>

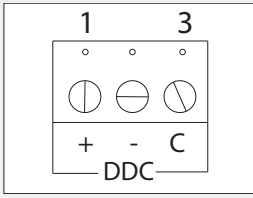
<p><b>Connector J25</b> contains low voltage screw terminal connections for DDC Communications Isolated</p>	
<p><b>Pin 1</b> - RS-485 +  <b>Pin 2</b> - RS-485 -</p>	<p><b>Pin 3</b> - RS-485 Common</p>

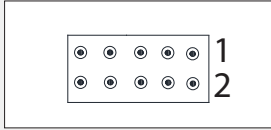
<p><b>Connector J26</b> Programming Port</p>	
--	---

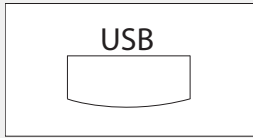
<p><b>Connector J27</b> USB Programming Port</p>	
--	---

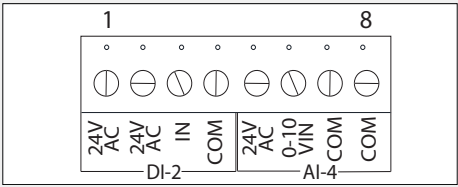
<p><b>Connector J28</b> contains low voltage screw terminal connections</p>	
<p><b>Pin 1</b> - 24VAC Start Command for 3rd-Party VFD  <b>Pin 2</b> - 24VAC Output  <b>Pin 3</b> - 24VAC Trouble Input  <b>Pin 4</b> - 24VAC Common for 3rd-Party VFD</p>	<p><b>Pin 5</b> - 24VAC Constant Output  <b>Pin 6</b> - 0-10VDC Analog Input VFD Speed Reference  <b>Pin 7</b> - 24VAC Common  <b>Pin 8</b> - 24VAC Common</p>

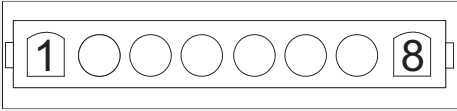
<p><b>Connector J29</b> contains 120V AC connections</p>	
<p><b>Pin 1</b> - 120VAC Blower Service Switch Input  <b>Pin 2</b> - 120VAC Burner Service Switch Input  <b>Pin 3</b> - 120VAC High Temp Limit Input  <b>Pin 4</b> - 120VAC Output to FSC (6)</p>	<p><b>Pin 5</b> - 120VAC Output to FSC (7)  <b>Pin 6</b> - N/A  <b>Pin 7</b> - Purge/Dry Contacts Output  <b>Pin 8</b> - 120VAC Neutral</p>

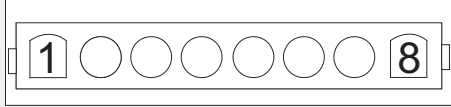
<p><b>Connector J30</b> contains 120V AC connections</p>	
<p><b>Pin 1</b> - 120VAC Input from Pilot Gas FSC (3)  <b>Pin 2</b> - 120VAC Pilot Gas Output - Connected to J30-1  <b>Pin 3</b> - 120VAC Input from Spark FSC (4)  <b>Pin 4</b> - 120VAC Spark Output</p>	<p><b>Pin 5</b> - 120VAC Input from Main Gas FSC (5)  <b>Pin 6</b> - 120VAC Main Gas Output - Connected to J30-5  <b>Pin 7</b> - 120VAC Alarm Input from FSC (A)  <b>Pin 8</b> - 120VAC Alarm/Trouble Output</p>

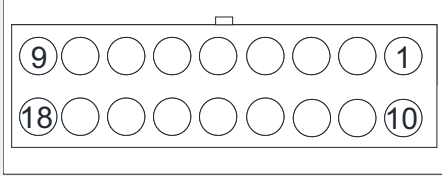
<p><b>Connector J31</b> - Contains inputs and outputs for components</p>	
<p><b>Pin 1</b> - 24VDC + Output to Profile / Main Air Flow Pressure Sensor  <b>Pin 2</b> - 0-10VDC Analog Input from Profile/Main Air Flow Pressure Sensor  <b>Pin 3</b> - 24VDC/0-10VDC Common from Profile/Main Air Flow Pressure Sensor  <b>Pin 4</b> - N/A  <b>Pin 5</b> - N/A  <b>Pin 6</b> - N/A  <b>Pin 7</b> - 24VDC + Output to Manifold Gas Pressure 1 Sensor  <b>Pin 8</b> - 0-10VDC Analog Input from Manifold Gas Pressure 1 Sensor  <b>Pin 9</b> - 24VDC/0-10VDC Common from Manifold Gas Pressure 1 Sensor</p>	<p><b>Pin 10</b> - 24VDC + output to Manifold Gas Pressure 2 Sensor  <b>Pin 11</b> - 0-10VDC Analog Input from Manifold Gas Pressure 2 Sensor  <b>Pin 12</b> - 24VDC/0-10VDC Common from Manifold Gas Pressure 2 Sensor  <b>Pin 13</b> - 24VDC + output to Clogged Filter Pressure Sensor  <b>Pin 14</b> - 0-10VDC Analog Input from Clogged Filter Pressure Sensor  <b>Pin 15</b> - 24VDC/0-10VDC Common from Clogged Filter Pressure Sensor  <b>Pin 16</b> - 24VDC + Output for Analog or Static Pressure Control for Blower/Damper  <b>Pin 17</b> - 0-10VDC Analog Input for Analog or Static Pressure Control for Blower/Damper  <b>Pin 18</b> - 24VDC/0-10VDC Common for Analog or Static Pressure Control for Blower/Damper</p>

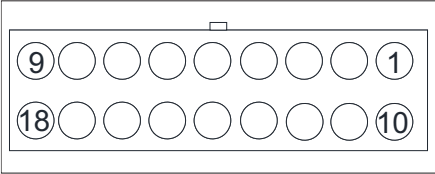

<p><b>Connector J32</b> contains inputs and outputs for components</p>	
<p><b>Pin 1</b> - N/A  <b>Pin 2</b> - N/A  <b>Pin 3</b> - 24VAC Output for Proof Of Closure  <b>Pin 4</b> - N/A  <b>Pin 5</b> - 24VAC Output To CO Alarm  <b>Pin 6</b> - 0-24VDC + Analog Input from Flame Sensor  <b>Pin 7</b> - 24VDC Powered PWM to Modulating Gas Valve, Full Wave, 16 kHz  <b>Pin 8</b> - 0-10VDC Out for VFD  <b>Pin 9</b> - 0-10VDC Out for EF</p>	<p><b>Pin 10</b> - N/A  <b>Pin 11</b> - N/A  <b>Pin 12</b> - 24VAC Input from Proof of Closure  <b>Pin 13</b> - N/A  <b>Pin 14</b> - 24VAC From CO Alarm  <b>Pin 15</b> - 24VDC Common From Flame Sensor  <b>Pin 16</b> - 24VDC Powered PWM to Modulating Gas Valve, Full Wave, 16 kHz  <b>Pin 17</b> - 0-10VDC Common for VFD  <b>Pin 18</b> - 0-10VDC Common for EF</p>

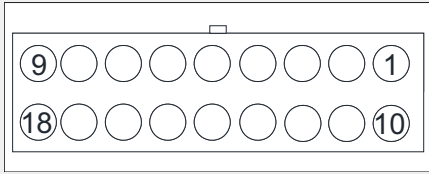
<p><b>Connector J33</b> contains inputs and outputs for components</p>	
<p><b>Pin 1 through 8</b> - N/A  <b>Pin 9</b> - 0-10VDC Analog Input for CFM</p>	<p><b>Pin 10 through 17</b> - N/A  <b>Pin 18</b> - 0-10VDC Common for CFM</p>

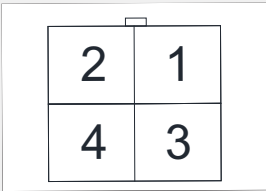
<p><b>Connector J34</b> - N/A</p>	
-----------------------------------	--

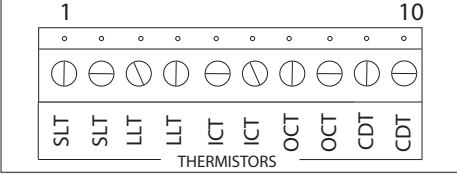
<p><b>Connector J35</b> N/A</p>	
---------------------------------	--

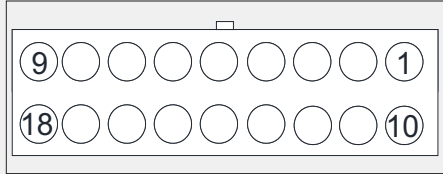
<p><b>Connector J36 N/A</b></p>	
---------------------------------	--

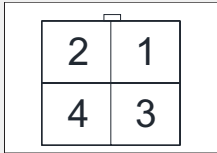
<p><b>Connector J37 N/A</b></p>	
---------------------------------	---

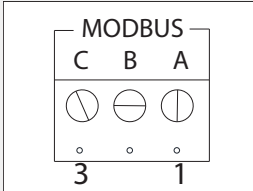
<p><b>Connector J38 Modbus</b></p>	
<p><b>Pin 1 (A) - Modbus (-)</b> <b>Pin 2 (B) - Modbus (+)</b></p>	<p><b>Pin 3 (C) - Modbus Ground</b></p>

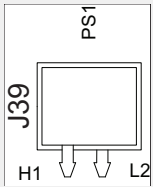
<p><b>Connector J39 Onboard Airflow Switch</b></p>	
<p><b>H1 - High Side</b></p>	<p><b>L2 - Low Side</b></p>

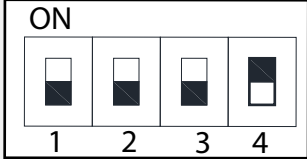
<p><b>Dip Switch S1</b></p>	
<p>Switch 1, 2, 3 always OFF. Switch 4 Always ON. If Switch 4 is OFF, BAS terminals disabled.</p>	

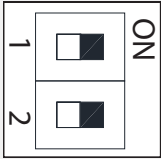
<b>Dip Switch S2</b>	
Programming - Service Only	

<b>Dip Switch S3</b>	
End of line termination	

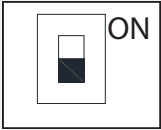
<b>Dip Switch S4</b>	
Programming - Service Only	

## Duct Static Pressure Control

Units equipped with an Electrically Controlled Motors (ECMs) or Variable Frequency Drives (VFDs) driven supply fan, the duct static pressure control option can be used to monitor duct pressure.

1. Locate where the pressure transducer is installed in the control cabinet.
2. Install the static pitot tube in a straight section of ductwork where the airflow is laminar and consistent.
3. Connect the high side tubing to the static pitot tube.
4. Route the tubing through the bottom of the unit to the high side port on the pressure transducer.
5. The low side pressure tubing will be connected to a brass port, measuring outdoor ambient pressure. The port is located by the unit's control cabinet doors. This will be connected from the factory.

Figure 13 - Duct Static Pressure Control

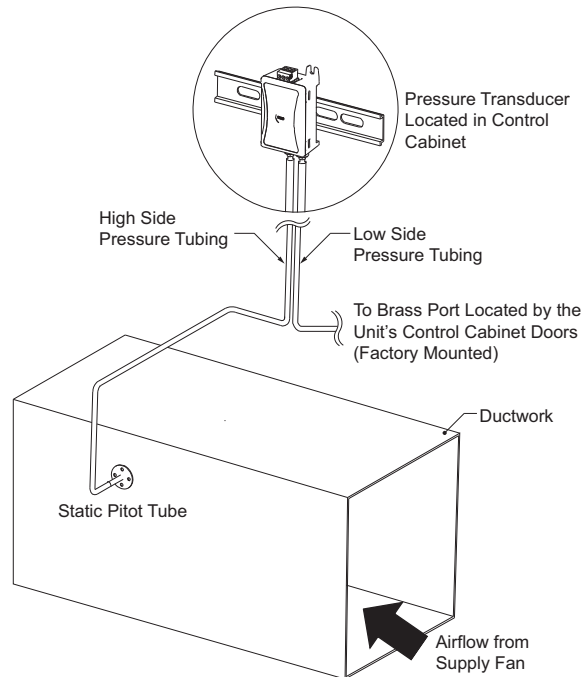

## Building Static Pressure Control

Units equipped with an Electrically Controlled Motors (ECMs) or Variable Frequency Drives (VFDs) driven supply fan, the building static pressure control option can be used to monitor space pressure.

1. Locate where the pressure transducer is installed in the control cabinet.
2. Determine the space monitoring device:
  - Remote HMI, refer to “**HMI and Remote Room Sensor Installation**” on page 29
  - Room Pressure Pickup Sensor
3. Install the space monitoring device in the space.
4. Connect the high side tubing to the space monitoring device.
5. Route the tubing through the bottom of the unit to the high side port on the pressure transducer.
6. The low side pressure tubing will be connected to a brass port, measuring outdoor ambient pressure. The port is located by the unit's control cabinet doors. This will be connected from the factory.

Figure 14 - Building Static Pressure Control

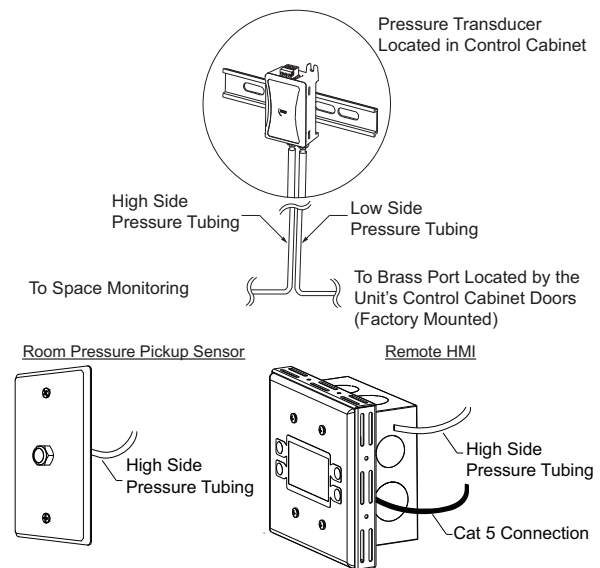

## HMI and Remote Room Sensor Installation

The HMI (Human Machine Interface) is used to change settings, view operating information, and view fault history. Remote HMI faceplates (**Figure 15**), remote room sensors (**Figure 16**), and smart controls may be ordered and shipped separately. These components measure temperature and humidity and assist in controlling the unit. These components should be installed in a safe location, free of influence from external heat sources. Sensors must be installed in areas indicative of the average room temperature. Mounting the sensor(s) to interior walls will provide reliable measurements. Keep the sensor away from heat-producing appliances, direct sunlight, and away from operable windows/doors.

HMI and remote room sensors can be installed directly to industry-standard junction boxes, either surface mounted or recessed mounted. HMIs have a built-in temperature/relative humidity (RH) sensor, which is typically used to help control the automatic function of the unit.

The HMI can also be configured to control the unit from a remote location manually. They can be configured not to use the internal temperature/relative humidity sensor. In this configuration, the sensor in the HMI is ignored in automatic operation. Multiple HMIs can be connected to one unit for temperature and R/H averaging. All combination temperature/humidity HMIs will use a vented standoff. Mount the static pressure tube close to the HMI to obtain proper room conditions.

A max of 4 additional HMIs can be daisy-chained together. Place an End-of-Line (EOL) device in the last HMI connected.

**Figure 15 - HMI with Standoff**

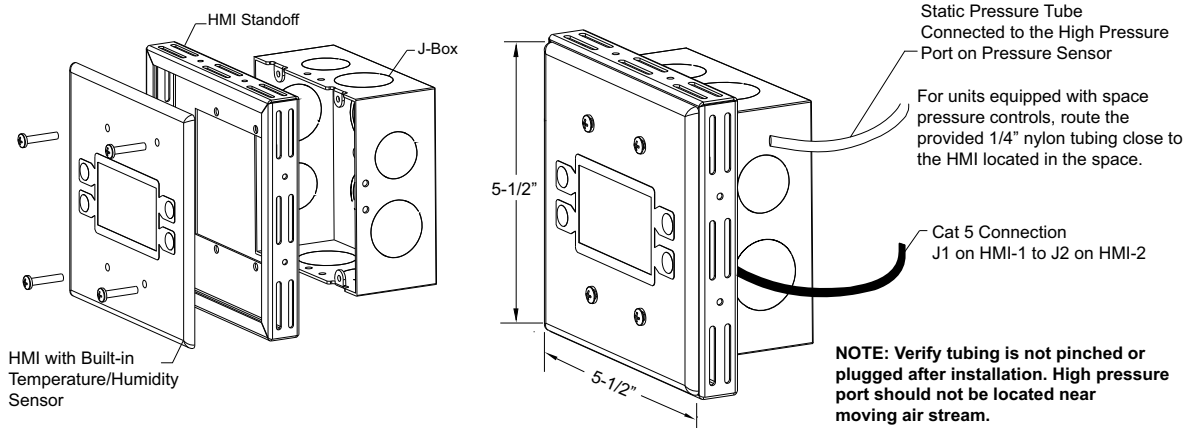
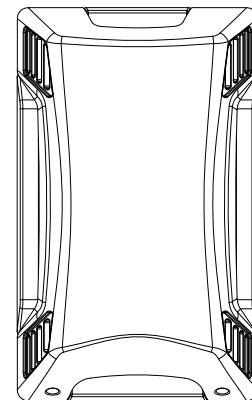

**Figure 16 - Remote Temp/RH Sensor**

The room temperature/humidity sensor is a 10K ohm thermistor. When connected to the 0-10V humidity sensor connection, the sensor provides constant room temperature and humidity (RH) readings to the controller. The sensor should be installed on a wall somewhere in the room, but not directly in the HVAC diffuser's path or close to heat-producing appliances so that the reading is not affected by heat.

Room sensors are not required for proper control operation, but still can be configured as remote sensors or averaging sensors.

**Do not install the room sensor on the ceiling.**



## Temperature Control

**Discharge Control:** When used in discharge control, the MUA Board receives a call to heat from the intake sensor. The MUA Board will modulate the discharge temperature until the desired set point is reached. The user can choose whether discharge heating/cooling is activated based on intake temperature, space temperature, either, or both.

**Space Control:** When selected, an HMI with an internal temperature sensor or a temperature sensor wired to ST terminals on the MUA Board can be used to sense space temperature. The user can choose whether the space heating/cooling is activated based on intake temperature, space temperature, either, or both.

**Analog Control:** If Analog Control is utilized, DIP switch #4 on the MUA Board should be set On. Blower/Heating/Cooling will be controlled by a 0-10V DC or 0-20mA signal based on input source.

Scan for DDC Application Guide

**Direct Digital Control (DDC):** A 0-10V DC or 0-20mA signal is sent to the MUA Board from the building control system to regulate the blower/heating output of the unit. For DDC information, refer to [DDC Application Guide](#).



In all cases, the MUA Board controls the amount of gas to the burner based on the signal from the temperature control components.

## Maxitrol Modulating Valve

The operation of the modulating gas valve with regard to voltage is as follows: from 0 volts to approximately 5 volts, the modulating gas valve should be on bypass flow with the heater operating on low or minimum fire. From approximately 5 volts to 15 volts DC, the valve should be performing its modulating function, and the heater should be firing at a modulated flow rate between low and high fire, depending upon the voltage. Above approximately 15 volts DC, the valve should be delivering full flow to the heater and the unit should be on high fire.

## RTC Modulating Valve

The operation of the modulating gas valve with regard to voltage is as follows: From 2 volts to 10 volts DC, the valve should be performing its modulating function, and the heater should be firing at a modulated flow rate between low fire and high fire, depending upon the voltage. The low fire and high fire voltage limits are set in the factory settings.

## Thermistor

The temperature sensor (**Figure 17**) is a 10K ohm thermistor. The sensor gives constant feedback to the control board.

Figure 17 - Temperature Sensor

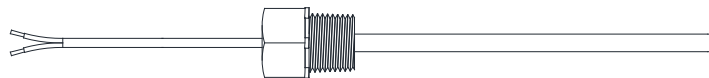

## Thermistor Connected to HMI

Thermistors connected to connector J5 on the HMI may be averaged or used as a standalone for space temperature readings.

# OPERATION

## Accessing Menu Configurations

### General Overview

The HMI (Human Machine Interface) allows the user to change parameters and options. The user may use the HMI to view operating information regarding sensors, temperatures, pressures, and fault history on the HMI screen (**Figure 18**).

There are four buttons to navigate through the HMI screens.

**NOTE: Buttons change functions during certain options and tests. Verify the screen and buttons throughout the menu display.**

When the HMI Home Screen (**Figure 20**) is active, the Temp +/- buttons may be used to adjust basic temperature settings. Adjustments made are not permanent, and are based on Occupancy Configuration and Override Duration parameters in Factory Settings.

The user can access the Top Menu HMI configurations by pressing the top two buttons simultaneously. To exit this screen, simply press the 'BACK' button. When setting certain options or functions, pressing the 'BACK' button multiple times will bring up the save screen (**Figure 19**). The user may select 'YES' to save the changes, select 'NO' to return to factory settings, or select 'CANCEL.' When selecting 'CANCEL,' any changes made will not be saved, and the screen will return to the top menu.

The HMI menu system allows full access to every configurable parameter in the HMI. The parameters are factory configured to the specific application. Parameters may need to be modified to fine-tune automatic operation after the original setup.

### Remote (HMI) Control Panel

On units shipped with a space HMI, a Cat 5 cable will need to be run from J4, J5, or J6 (refer to schematics) on the main MUA Board to J2 on the HMI. If additional space HMIs have been added, they can be daisy-chained from the first HMI. In the event there is a slave MUA Board, HMIs can also be powered from J1 or J2 of the slave board. An end of line resistor should be added to the last HMI in the chain.

### HMI Notification Letters

The HMI will display notification letters (**Figure 20**) when the unit is in a specific status.

- B = Blower Start or Blower Stop Delay Active
- C = Condenser Min On or Min Off Timer Active. Displayed when any of the condensers are in a Min On/Off Time.
- D = Min or Max Discharge Temp Reached.
- M = Max Temp Rise Reached.
- R = OA Reset.
- Δ = Dynamic SP Applied.

**Figure 18 - HMI Screen**

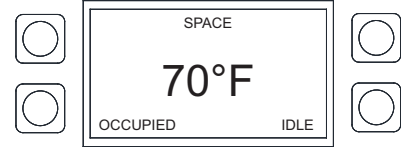

**Figure 19 - Save Screen**

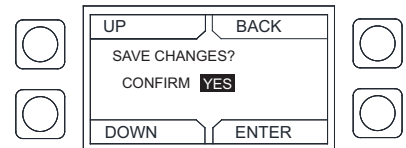

**Figure 20 - Notification Letters**

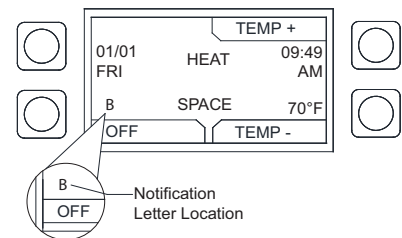

## HMI Configuration Menu

To enter the configuration menu (**Figure 21**), press the bottom two buttons simultaneously on the HMI faceplate. In this menu screen, you may adjust Communication and Advanced Options, check Status, and About information.

**Figure 21 - Configuration Menu**

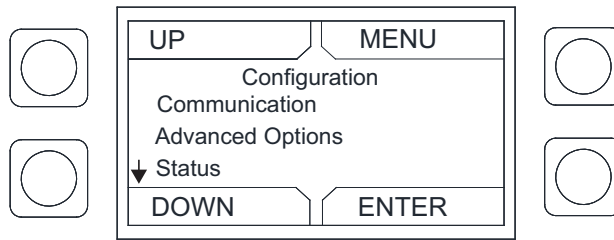

### Communication

Under the communication menu, the user may adjust the following settings:

- **Modbus Address** - Default is 55 for the first HMI. For every additional HMI, increase the address by one. For example, if a second HMI is used, the Modbus Address should be 56. For a third HMI, the Modbus Address should be 57.
- **Baud** - The baud rate address is 115200.
- **Parity** - Do not adjust this setting. The default setting should always be set to 'EVEN.'

### Advanced Options

Under advanced options, the user may adjust the following settings:

- **Contrast** - The user may adjust the setting from 0 to 10. Setting the contrast to 0 is the lowest setting available, and 10 is the highest contrast setting available. The factory default contrast setting is 5.
- **Audio Enable** - User may set the audio to off.
- **Dimming Enable** - Default is set to Off. If set to On, the 'HMI Dimming Timer' option will be available.
- **Set Time** - The user may adjust dimming setting from 10-60 seconds. The default time is 30 seconds.
- **RH Chip** - Relative Humidity sensor manufacturer. This setting is auto-detected. **DO NOT CHANGE SETTING.**
- **Temp Offset** - Applies a temperature offset to the space HMI reading utilized by MUA Board. Must be set local to each space HMI. Range +/- 20°F. Calibrated individually from the manufacturer. User must consult with manufacturer before making adjustments.
- **RH Offset** - Applies a relative humidity offset to the space HMI reading utilized by MUA Board. Must be set local to each space HMI. Range +/- 30%. Calibrated individually from the manufacturer. User must consult with manufacturer before making adjustments.
- **PS Offset** - Applies a pressure offset to the space HMI reading utilized by MUA Board. Must be set local to each space HMI. Range +/- 200 mb. Calibrated individually from the manufacturer. User must consult with manufacturer before making adjustments.

### Status

User may monitor board temperature status, Uptime (how long the board has been active since last restart), HW RH (HMI hardware humidity sensor), HW Temp (HMI hardware temperature sensor).

### About

User may view SCADA HMI Software Version, Modbus Address (assigned to HMI), Baud (115200).



## Scheduling

To set a schedule on the HMI (**Figure 22**), you must first enable scheduling: **Factory Settings > Occupancy Config > Scheduling > On**

Set your sensor temperature set points for occupied and unoccupied schedules: **User Settings > Temp Set Points > (Varies)**

Once scheduling is enabled and the temperature set points are configured, you may enter your scheduled days and times: **User Settings > Scheduling**

### Schedule A Default

- Monday - Friday  
8:00AM to 6:00PM
- Saturday and Sunday  
Unocc

### Schedule B Default

- Monday - Friday  
Unocc
- Saturday and Sunday  
Unocc

### Schedule C Default

- Monday - Friday  
Unocc
- Saturday and Sunday  
Unocc

**Figure 22 - Scheduling Screen**

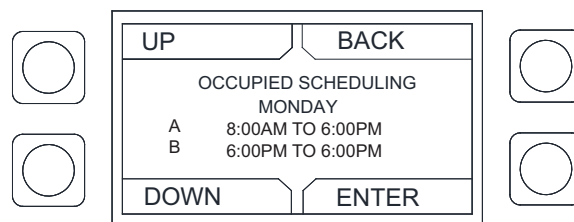

To adjust the settings, highlight the parameter and press **ENTER**.

- The first parameter to be highlighted will be the day. Press **UP** or **DOWN** to select the day an occupied time schedule is required.
- Press **ENTER** to continue to set a start time. Press **UP** or **DOWN** to set start time.
- Press **ENTER** to set an end time. Press **UP** or **DOWN** to set end time.

The system will run between these days, time, and desired temperature settings. When in the UNOCCUPIED setting, the system will run at the unoccupied temperature settings.

## Unit Options

### Communication Module (Optional)

The Communication Module, PN: **SCADA**, is included in all CASlink equipped panels. It obtains operational data from various connected components. This communication wiring is either RS-485 shielded twisted pair wiring or RJ45 Cat 5 Ethernet wiring.

### Building Signal Damper Control

When this option is ordered, the outdoor air (supply) and return dampers will modulate based on a 0-10V DC signal from the Building automation system. 0V = max outside air, 10V = max return air. Direct fired units cannot go below 20% outside air, maximum output voltage may differ.

### Electric Cabinet Heater

Units can be shipped with an optional 120V electric cabinet heater powered from the MUA Board. There is a temperature sensor built onto the MUA Board that will regulate when the cabinet heater activates. To enable this option go to **Factory Settings > Unit Options > Cabinet Heater > Enable**. Temperature readings and adjustments can be made through the HMI. Go to **User Settings > Temp Set Points > Option Set Points > Cab Heat Set Points**.

### Motorized Intake Damper

On units shipped with the optional motorized intake damper, a power transformer is supplied with the unit if the main incoming voltage is greater than 120V. No external wiring to the damper motor is required.

## Mixing Box Control Unit Options

**Manual Control** - The dampers can be controlled from the HMI in the unit or from a space HMI if one is provided to any position from 20% to 100% fresh air. This is a 0-10V setting, which is available under user settings, 100% Outdoor Air (0 volts), 80% Return Air (equivalent voltage). This will allow to manually set the dampers to match the building ventilation requirements. On a power failure, the return air damper will close by spring return.

**Two Position Control** - The dampers can be controlled by a two-position switch (a field-supplied switching device) to open the fresh air to 100%. The MUA Board sends out a constant voltage. The field supplied switch will cut or allow the signal from the MUA Board to the mixing box damper. On opening of the circuit, power failure, or if the unit is shut off, the return air damper will close by spring return. If the circuit is closed, the MUA Board will allow the return air damper to open per the set point.

**Outdoor Air %** - The dampers can be controlled from the HMI in the unit or from a space HMI if one is provided to any position from 20% to 100% fresh air. There is an outdoor air percentage setting that is available under user settings. This will allow the user to manually set the dampers to match the building ventilation requirements.

- When preset OA is On, the unit will use preset values for mixing box OA% by directly associating OA voltage to OA percentages. A calibration can be run from the service menu to store and use real-world results rather than provided defaults.
- When preset OA is Off, the MUA Board utilizes an internal algorithm to alter its 0-10V output to the mixing box damper in order to maintain an exact outdoor air percentage. When this mixing box option is selected, a mixing box dead-band comes into play. This setting checks the delta T between outdoor and return air. If the difference between these two temperatures is less than or equal to the mixing box dead-band setting, the MUA Board will not alter its output to the mixing box damper (default setting is 5 degrees). On a power failure, or if the unit is turned off, the return air damper will close by spring return.

**Analog Control** - When this is set to ON, a 0-10V input will drive the damper output to modulate linearly between the min and max OA voltage for both occupied and unoccupied modes.

**Static Pressure Control** - Damper position will modulate to maintain building pressure. Building pressure below the set point will increase the amount of outdoor air supplied to increase pressure. Building pressure above the set point will decrease the amount of outdoor air supplied to decrease pressure.

**CO2 Control** - When the unit senses the CO2 input to be above the threshold setting, the unit will decrease mixing box output until the CO2 falls below threshold setting.

# Menu Descriptions

**User settings:** Allows the user to change or set certain temperatures and configurations on the unit.

**Factory settings:** Requires a password (1111) to enter this menu. Factory settings are job-specific and configured from the plant. Any changes to the factory settings will require the user to save the updated changes.

**Service:** Requires a password (1234) to enter this menu. Allows a certified technician to monitor the unit and test components in the system.

**About:** Unit type and software revision information.

## User Settings

**Temp Set Points** - Some or all of these set points (SP) may not be available based on settings. If scheduling is enabled, there will be occupied and unoccupied values for set points. The user will be allowed to view/ adjust the set points/limits.

- **Intake Set Points** - Adjustable intake activation SP.
  - **Heat** - Activate Based On must be set to Intake, Both, Either, or Stat. Heating stage must = 1.
  - **Cool** - Activate Based On must be set to Intake, Both, Either, or Stat. Cooling type set to DX or both.
  - **Evap** - Activate Based On must be set to Intake, Both, Either, or Stat. Cooling type set to Evap or both.
- **Discharge Set Points** - Adjustable heat discharge activation SP.
  - **Heat** - Tempering mode must be set to discharge. Heating stage must = 1.
- **Space Set Points** - Adjustable heat/cool space activation SP.
  - **Heat** - Activate Based On must be set to Space, Both, or Either. Heating stage must = 1.
  - **Cool** - Activate Based On must be set to Space, Both, Either, or Stat. Cooling type set to DX, Evap or both.
- **Discharge Limits** - Adjustable discharge limit SP.
  - **Min** - Cannot be greater than maximum discharge heat SP.
  - **Max** - Cannot be less than minimum discharge heat SP.
- **Differentials** - Adjustable intake/cool space SP.
  - **Intake** - Activate Based On must be set to Intake. Cool tempering mode set to Intake.
  - **Space** - Activate Based On must be set to Space. Cool tempering mode set to Space.
- **Option Set Points** - Adjustable set points for options that are enabled to "ON" in Factory Settings.
  - Room Override, Firestat Set Points, Freezestat Set Points, Cab Heat Set Point, Evap Drain Set Point, Warm Liq Set Points, OA Reset Low, OA Reset High, Reset Heat Discharge, Reset Heat Space, Reset Cool Space, Disable Space Sensor.

**Dry Mode Config** - The user will be allowed to view or adjust dry mode set points/limits when the option is enabled.

**Scheduling** - Menu will display when scheduling is set to On.

- **Scheduling Times** - Days contain the option for three occupied time periods. Time periods cannot overlap.
- **Schedule Copy** - This will allow the user to copy an existing schedule from one day of the week to individual days in the week, to Week Days, or All.

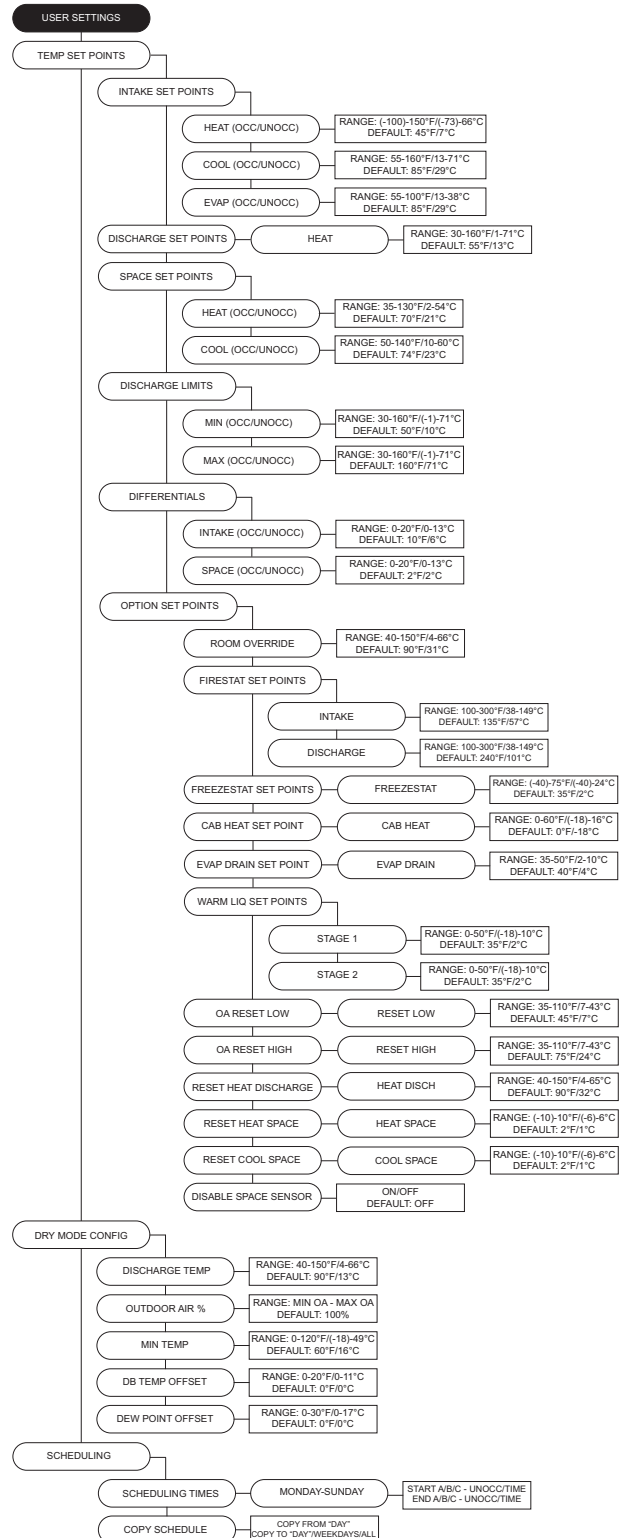

**Fan Speed** - Enabled when the supply fan is controlled by a VFD or ECM. The range of this menu is limited by the min and max Set Points (SP) under factory settings. When the fan is set to VFD, the settings will be displayed in: Hertz (VFD by Other = OFF); Volts (VFD by Others = ON). When the fan is set to ECM, the PWM percentage will be displayed.

**Clogged Filter SP** - Displayed when “Filter Mon” is set to sensor in **Factory Settings > Unit Options > Monitoring Sensors**. This adjustable SP will display a fault on the HMI when the reading is below SP for five minutes.

**Mixing Box Setting** - Mixing box will allow outdoor air in vs. return air. 0V out is equal to 100% OA and 0% RA.

**Pressure Config** - Settings vary based on **Factory Settings > Unit Options > Pressure Config**.

- **Blower PS SP** - Adjustable blower pressure set points.
- **OA PS SP** - Adjustable outdoor air pressure set points.

**Single Zone VAV** - When single zone VAV is enabled to the blower, damper, or both, depending on settings, will modulate linearly between min and max discharge.

- **Blower Speed Heat** - Blower to modulate with discharge temp min discharge, min blower speed. Max discharge, max blower speed. Scaled linearly between min/ max discharge to min/max blower speed.
- **Damper Pos Heat** - Damper to modulate with the discharge temp min discharge, min damper position. Max discharge, max damper position. Scaled linearly between min/max discharge to min/max damper position.
- **Blower Speed Cool** - Blower speed will change depending on how many cooling stages are active. Evap counts as 1st stage of cooling.
- **Damper Pos Cool** - Damper position will change depending on how many cooling stages are active. Evap counts as 1st stage of cooling.

**Active Faults** - Contains the current faults on the board.

**Fault History** - Displays time-stamped history of the last 20 faults. The most recent fault will show first.

**Reset Lockouts** - Reset lockout faults.

**Dynamic SP Diff** - Temperature differential for dynamic set point change.

**Dynamic SP Offset** - Setting will adjust dynamically based on outdoor air conditions. For more information, refer to “Dynamic Set Point” on **page 46**.

**Dynamic Heat OA** - Outdoor air dynamic heat set point.

**Dynamic Cool OA** - Outdoor air dynamic cool set point.

**CO2 Control Config** - CO2 Parts Per Million (PPM) set points and sensor settings.

- **PPM Low/High** - CO2 PPM threshold set points for the space, used in CO2 Override.
- **PPM Limit** - CO2 PPM threshold limit set point.
- **Sensor Min/Max** - Set minimum and maximum range setting for CO2 sensor.

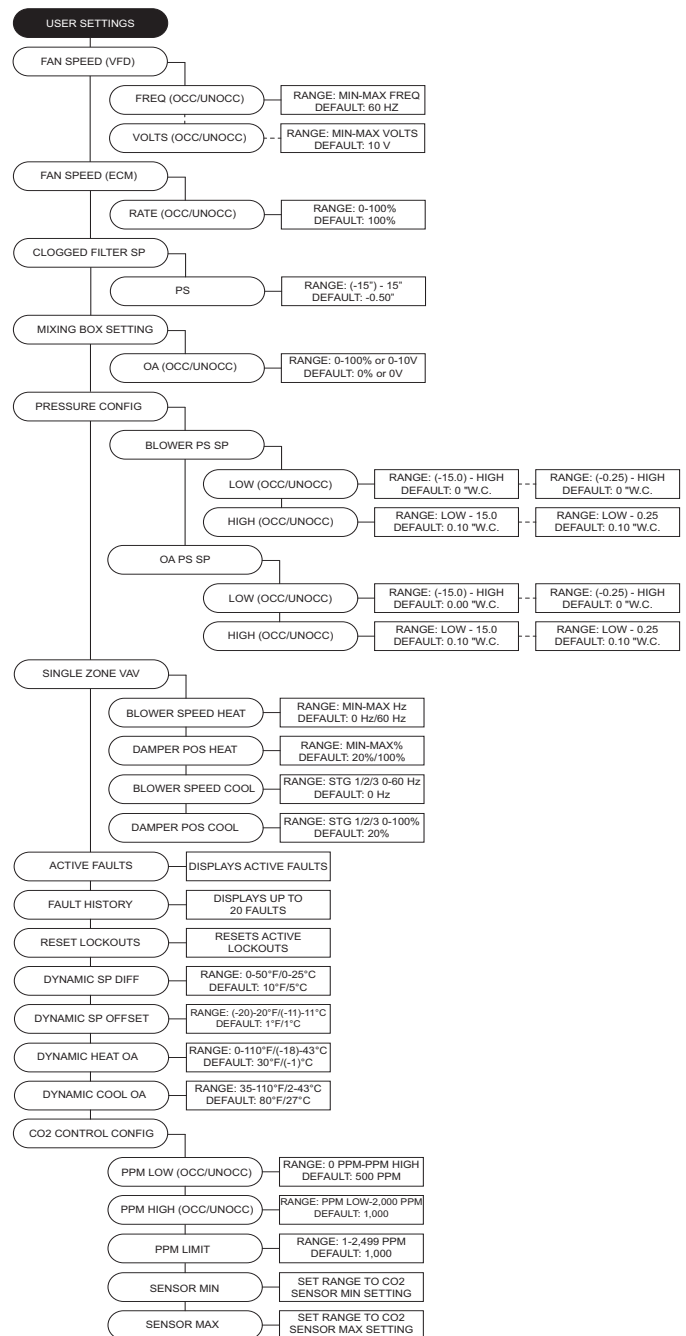

**Factory Settings** Menu Password = 1111.

**Heating Type** - Unit heating type set from the factory.

**Temperature Control** - The MUA Board monitors temperature control set points and components.

- **Tempering Mode** - The options for controlling the output of the tempering mode in heat/cool (if equipped). Available options are Intake/Discharge/Space/Analog Control/Direct Digital Control (DDC).
- **Activate Based On** - Unit activation based on temperature readings: Intake/Space/Both/Either/Stat (field installed thermostat). Settings can be altered for occupied and unoccupied preferences.
  - When Activate Based On is set to Stat, thermostat inputs and intake temperatures are monitored to activate heating/cooling.
- **Activation Sensor** - Selection for unit activation of intake or outdoor sensor.
- **Construction Mode** - Configurable option for units used in construction settings. When construction mode is enabled On, the following factory settings will be overridden: HMI, Discharge Control, 100% Outside Air, Activate Based on Intake, Blower Mode set to Manual.

**Heating Config** - Heating configurations/settings.

- **# of Heat Stages** - Default is set to 0 for units without gas heat. If the unit is equipped with gas heat, select 1.
- **Gas Type** - Select gas type: natural gas or propane.
- **Gas Valve Limits** - This setting adjusts the unit's gas valve range. You may adjust the Min or Max percentage range.
- **Low Fire Config** - Allows the user to set low fire time and valve position settings.
  - **Time** - The amount of time the low fire setting is applied before modulation will occur.
  - **Valve Pos** - Gas valve position before modulation occurs.
- **Heat Hyst** - Intake or Space tempering sensor must go this amount of degrees above the set point before heating turns off.
- **Input Source** - This lets the board know what signal (volts or milliamps) to expect from the analog control system. **Only valid for analog tempering mode.**
- **2nd Disch Sensor** - When an additional thermistor is added, the two thermistor readings will be averaged together.
- **Average High Temp** - When the "2nd Disch Sensor" is On, this menu will be available. When "Average High Temp" is Off, if either discharge sensor goes above high temp limit the unit will go into high temp lockout. When "Average High Temp" is On, both thermistors readings will be used to determine high temp lockout.
- **Pre Purge Config** - When enabled, this option will purge any gas that may not have combusted in the unit before the unit lighting off. You may set the amount of time the purge cycle will operate.

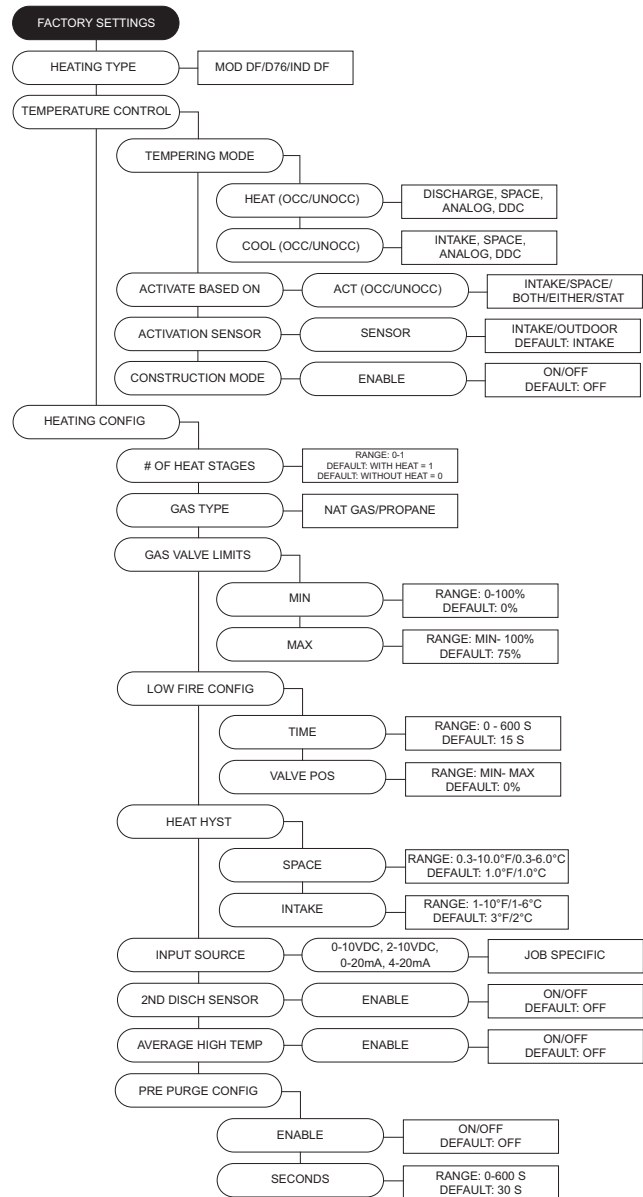

- **Cabinet Hyst** - The cabinet temp must reach this many degrees above the activation set point to turn off.
- **Freezestat Timer** - If the discharge temperature is below the freezestat set point for half the duration of the freezestat timer, the heat will shut off momentarily. If the freezestat trips for a second time, the heat will shut down immediately. Reset the lockout manually on the HMI.
- **Construction Heater** - When this option is set to On, settings will override any other airflow proving values and high-temperature setting.
- **Max Temp Rise Limit** - Compares max rise limit to calculated max temp rise. Software will always utilize the lower of the two values.
- **Blwr Off Flame Fail** - When enabled On, the blower will shut down if a flame lockout occurs. The blower may go back into operation after the fault is cleared.
- **HTL Blower Off** - The blower will shut off when the high temperature limit trips.
- **Min/Max Heating** - When enabled On, low fire percentage is configurable under **Service > Test Menu > Test Heating > Low Fire**.

**Cooling Config** - Cooling configurations/settings.

- **Cooling Type** - Cooling options are hidden if “None” is selected.
- **Extra Cooling Input** - When DX cooling stage is set to 2 or greater, the cooling input will utilize all cooling stages.
- **Min Cool OA Temp** - When the space temperature calls for cooling, and the outdoor air temperature is below the set point (SP), the unit will shut the condensers off. The blower will start and use outdoor air to cool the space.
- **Condenser Staging** - Condenser selections. Within the 2 and 3 condenser selection, there is another sub-menu that allows for 2 or 3 stages. For 2 condenser units, 3 stages should only be selected when the condensers are of unequal tonnages.
- **Cool Hyst** - Intake or Space tempering sensor must fall this many degrees below the SP before cooling turns off.
- **Condenser Min Times** - Minimum time each condensing stage must remain on after activation. This prevents stage cycling. **A “C” will be present in the lower-left corner of the home screen when any of the condensers are in a MIN ON/OFF TIME.**
- **DX Float Switch** - Enables DX float switch option.
- **Evap Config**
  - **Sprayer Times**
    - **Time On** - Evaporative cooler spray time on cycle.
    - **Time Off** - Evaporative cooler spray time off cycle.
  - **Evap Drain** - Units that use evap drain, set to On.
    - **Drain Hyst** - Temperature differential setting before the drain shuts off.
  - **Evap Hyst** - Temperature differential before the evap cooling shuts off.

**Occupancy Config** - Access to Scheduling/Override.

- **Scheduling** - Sets scheduling On/Off.
- **Override** - Sets occupancy override On/Off.

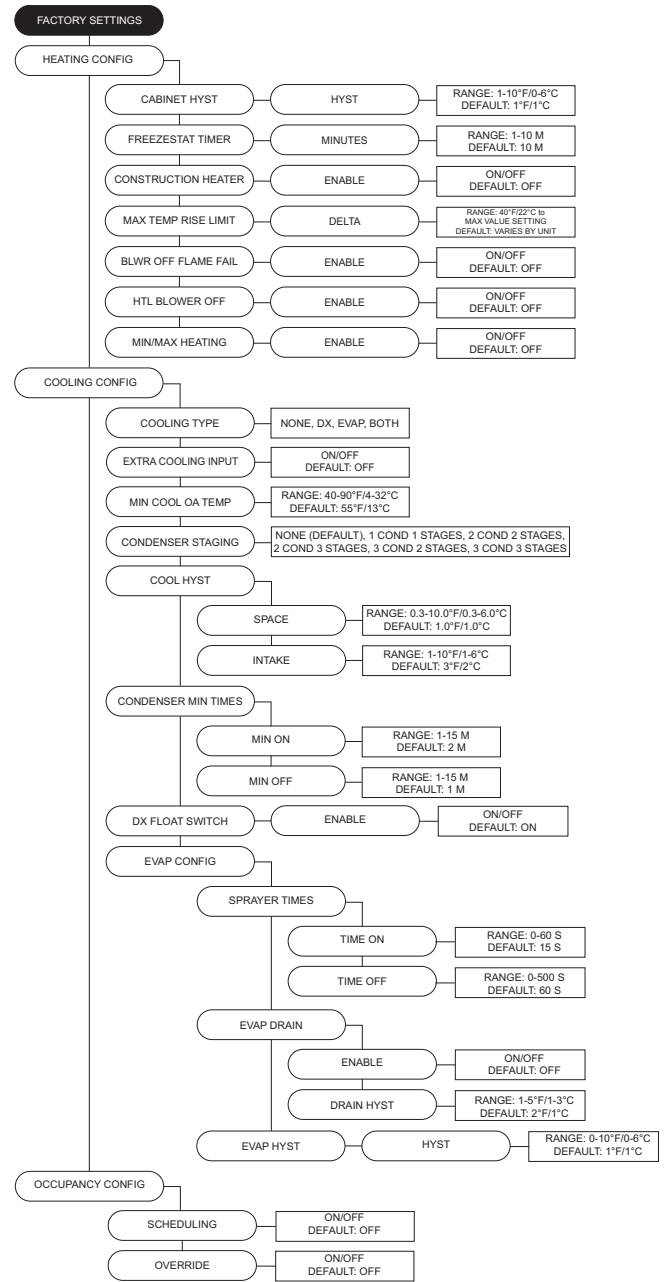

**Unit Options** - Access to options included with the unit.

• **Board Config**

- **Unit Address** - Modbus address of the MUA Board.
- **Startup Timer** - Time upon power-up where the board will sit idle.
- **Temp Readings** - Allows user to set temperature readings between Fahrenheit or Celsius. Changing between the two will reset all set points.

• **HMI Config** - Adjustment for HMI settings/options.

- **Number** - HMI count connected to the MUA Board.
- **Dis Space** - Select display space temperature option. Faceplate will display the room's current temperature. Average will display an average of all faceplates, excluding HMI in the unit, and all wired space sensor readings.
- **Screensaver** - When Off, the home screen will not time out to the screensaver.
- **Average HMI** - When multiple space HMIs are connected, this menu allows you to select which will be included in the space temperature and relative humidity averaging. If a thermistor or relative humidity sensor is connected into the ST screw terminals, it will automatically be averaged into any HMIs included. When in Space Tempering Mode, a minimum of one HMI must have Average HMI set to On, or a separate remote sensor must be used that is wired back to the MUA Board. When average HMI is set to more than 1, each HMI will have an averaging On/Off setting.
- **Temp Stat #** - On/Off option to turn on temperature averaging for wired HMI thermistors.
- **Lock Screen** - When On, a password (9999) will be required if; screensaver option is enabled or if any button functions are not pressed for 5 minutes.
- **Scnsvr Disp** - Displays date, time, and/or temperature/RH, when screensaver is active.

• **DDC Main Config** - Modbus communication info.

- **Baud** - The baud rate for Modbus.
- **Word Bits** - Data bit amount over Modbus.
- **Parity** - The parity selection for Modbus.
- **Stop Bits** - The stop bits selection for Modbus.

• **PGA HW Type** - (DO NOT CHANGE SETTINGS)

• **BMS Write Enable**

- **User Settings** - Allows BMS to write to user settings.
- **Factory Settings** - Allows BMS to write to factory settings.

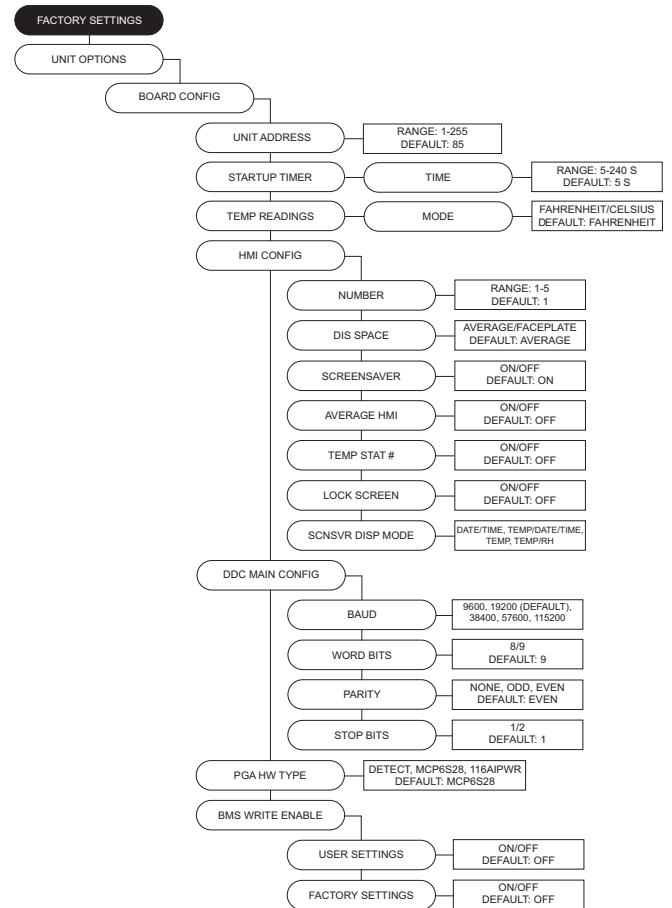



- **Blower Config** (refer to **Table 6** for aux pin settings).
- **Blower Control** - Select one of the following:
  - **120V Contactor** - 120V output on the MUA Board to energize the supply contactor coil. This option should be selected when the MUA is used in conjunction with a DCV package.
  - **VFD Manual** - HMI selectable VFD frequency.
  - **VFD Jog** - For use with VFDs using photohelic control. Aux pins are used to control the VFD. Powering aux 1 will speed the fan up, powering aux 2 will slow the fan down. When aux 1 or aux 2 are not powered, the VFD will hold current speed.
  - **VFD 0-10V** - For use when an external 0-10V signal is being provided to control the speed of the VFD. 0 Volts will equal VFD min, 10V will equal VFD max, and all voltages in between will be scaled linearly. This option will utilize 0-10V J28-(6) and 0-10V common J28-(7) screw terminals, and will require field wiring.
  - **VFD Pressure** - For use with VFDs that use a pressure transducer (0-10V output).
  - **Electronically Commutated Motor (ECM)** - HMI selectable PWM rate.
  - **ECM 0-10V** - For use when an external 0-10V signal is being provided to modulate the ECM supply output between min and max speed.
  - **ECM Pressure** - For use with ECMs that use a pressure transducer (0-10V output).
  - **ECP** - For use when the unit is controlled by an Electrical Control Package (ECP). MUA Board will still energize 120V supply contactor when there is a call for blower. Power to FSC cuts out at shutdown for 30 seconds.
- **Blower Mode:**
  - If "Occ" is set to On, the menu screen for the blower mode will allow you to choose ON/AUTO OFF for Occupied or Unoccupied.
  - If "Occ" is set to Off, the menu screen for the blower mode will allow you to choose MANUAL/AUTO/INTER-LOCK. In blower auto mode, the blower will only run when it gets a call for heating/cooling.
  - In blower manual/on mode, the blower will run as long as the fan button is enabled regardless of whether the unit is heating/cooling. In blower off mode, closing contacts J16-5 (unit intlk) and J16-6 (24V AC) will cause the blower to run.
- **Air Profile Limits** - Low PS cannot be adjusted below min setting, and High PS cannot be adjusted above max settings. Adjusting limits between min/max values may affect unit operation.
- **Blower Presets** - Sets blower preset option On/Off.
- **Post Purge Config** - This option will run the blower for the set time after heating has shut down.
- **Door Interlock** - When enabled, if the door is open, the supply fan will shut down immediately.

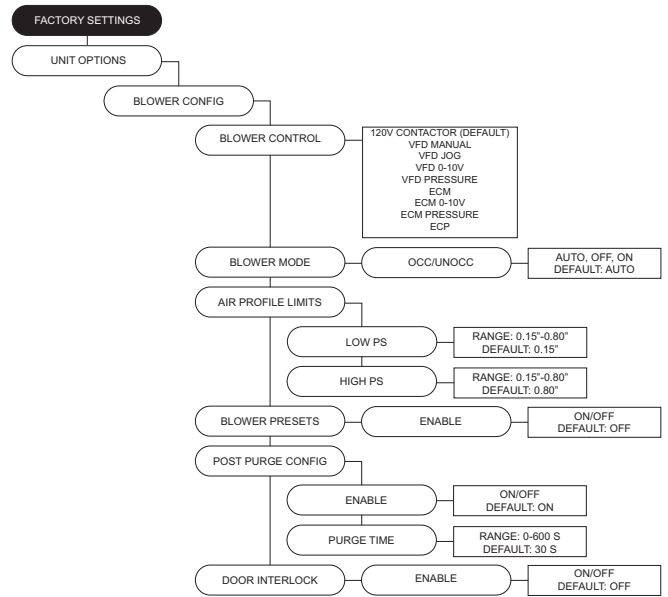

**Table 6** outlines the aux pins on Connector J11 for preset settings associated with fan speed and damper position found in **Factory Settings > Unit Options**.

**Table 6 - Aux Presets**

Presets	Aux 1	Aux 2	Aux 3
Normal Operation (Selected Blower Mode)			
Fan Speed/Damper Position 1	X		
Fan Speed/Damper Position 2		X	
Fan Speed/Damper Position 3	X	X	
Fan Speed/Damper Position 4			X
Fan Speed/Damper Position 5	X		X
Fan Speed/Damper Position 6		X	X
Fan Speed/Damper Position 7	X	X	X



- **Fan Proving Config** - The exhaust contactor must be set to Before Airflow or After Airflow. When enabled, the user may set the number of contactors used. Contactor 1 = Aux 2, Contactor 2 = Aux 3.
- **VFD Direction** - Sends a command to the VFD to run in forward or reverse.
- **VFD Freq Limits** - Min/Max settings for fan speed.
- **VFD Volt Limits** - Min/Max settings for 3rd-party VFDs.
- **PWM Rate Limits** - Min/Max settings for fan speed.
- **DD Wheel Size** - Selection for wheel size and settings.
  - **Size** - This selection is utilized for CFM monitoring. Dual blower models will have a '2' assigned after the wheel size model number.
  - **K2 Factor** - Used for supply CFM calculations.
- **Occ Fan Presets** - After the blower has started, the blower setting will use the aux pins to drive the preset occupied value.
- **Unocc Fan Presets** - After the blower has started, the blower setting will use the aux pins to drive the preset unoccupied value.
- Fan Preset Default: 1 = 40Hz, 2 = 50Hz, 3 = 0Hz, 4 = 60Hz, 5 = 0Hz, 6 = 0Hz, 7 = 0Hz.
- **Occ PWM Presets** - After the blower has started, the blower setting will use the aux pins to drive the preset unoccupied value.
- **Unocc PWM Presets** - Allows user to set unoccupied preset blower speed value.
- PWM Preset Default: 1 = 80%, 2 = 90%, 3 = 0%, 4 = 100%, 5 = 0%, 6 = 0%, 7 = 0%.
- **VFD By Others** - This option will be used when a factory provided Modbus control VFD is not utilized. A start command, as well as a 0-10 V output will be provided to the VFD.
- **VFD Current Limit** - This limits the max current to the VFD.
- **Pressure Config**
  - **Sensor Range** - Menu is available when any blower pressure or mixing box pressure option is selected.
  - **Static PS KP** - Proportionally constant value for static pressure measured in V/sec.
  - **Cycle Time** - Cycle time is the time between two consecutive readings.
  - **PS Hysteresis** - Percentage band between high and low static set points. This will reduce cycling of blower or damper. Increase this value if the blower speed or damper does not settle into a set point.
  - **PS Control Types** - The blower/outdoor air pressure control may be set to monitor Building/Duct pressure.
- **Airflow Proving** - Unit may be set to prove by switch, remote sensor, or onboard sensor.

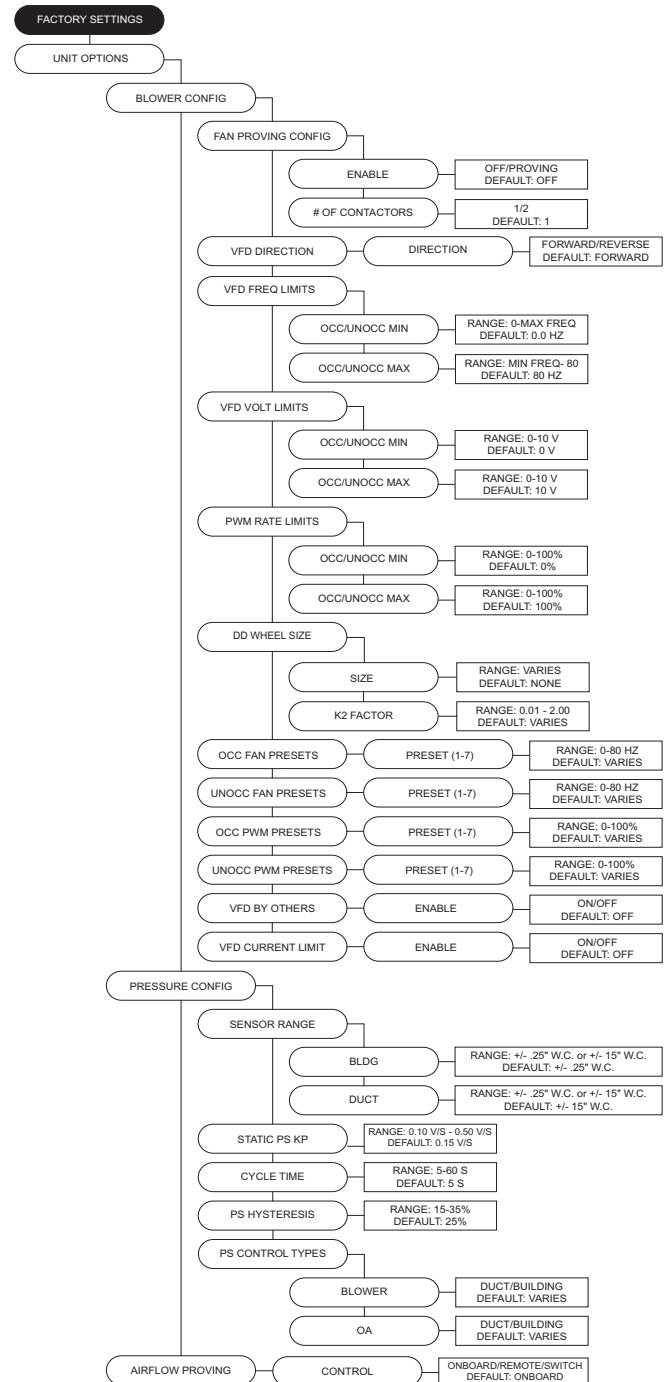

• **Purge Config**

- **Purge Button** - When the purge button is pressed, the damper will open to max outdoor air and turn on the exhaust contactor, if enabled. Purge Button must be enabled for Dry Mode use.
- **Purge Time** - This is the amount of time that the unit will run the purge process if the user does not stop the purge manually.
- **Purge Speed** - Adjustable between VFD or ECM. Min and Max frequency the fan will run during the purge cycle.
- **Dry Mode Config** - When this option is active (automatically or through manual button press), dry mode will run when:
  - Space Dew Point rises above Space DP set point (SP). Dry mode only.
  - In addition, if Summer Vent is ON, Space Dry Bulb rises above Space Dry Bulb SP and space enthalpy is greater than outside air enthalpy.
  - The unit will go to Dry Mode Discharge when there is a call for heat.
  - Space dew point is the average of the Space RH input with any additional HMI inputs.
  - If OA dew point < Space dew point, the mixing box should go to outdoor air set point. This should override any other mixing box functionality.
  - If OA dew point > Space dew point, the mixing box should go to min OA%.
  - Purge should run until the purge timer expires or the user cancels the purge.
    - **Exhaust** - Enables/disables exhaust contactor during dry mode.
    - **Space DP SP** - Dew point threshold for automatic dry mode activation.
    - **Space DB SP** - Dry bulb threshold for automatic dry mode activation.
    - **Space DP Hyst** - Hysteresis value applied to dew point setting.
    - **Summer Vent** - Dew point activation will enhance with enthalpy activation when set to On.
    - **CTR CTRL** - J29-7 will energize per the selected option.

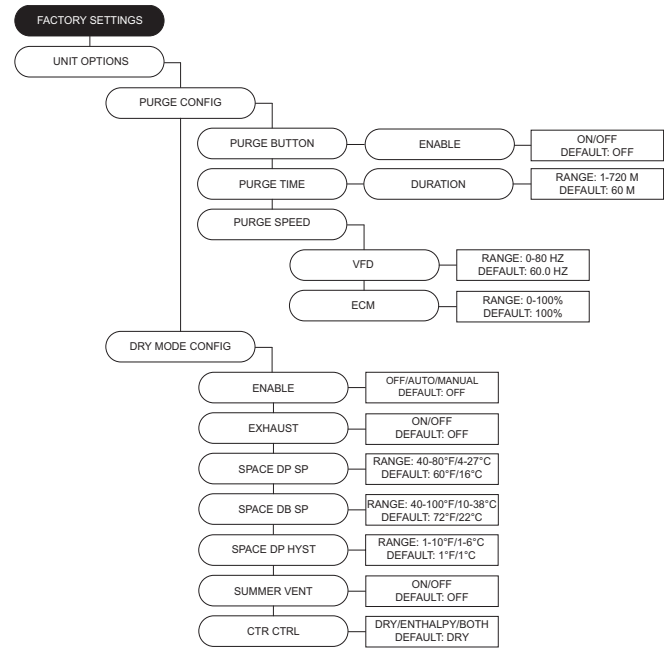

- **Monitoring Sensors** - This menu enables optional components from the factory or when field installed.
  - **Smoke Detector** - Enables for smoke detection.
  - **Filter Mon** - The option may be set to Off, Contacts or Sensor (J31-14). When set to Contacts or Sensor, if the input is active a fault will be displayed on the HMI.
  - **Intake Firestat** - When enabled, if the intake sensor is above the intake firestat set point, the unit will shut down immediately. A manual reset must be performed on the HMI.
  - **Discharge Firestat** - When enabled, if the discharge sensor is above the discharge firestat set point, the unit will shut down immediately. A manual reset must be performed on the HMI.
  - **Freezestat** - When enabled, if the freezestat sensor trips, the unit will shut down immediately. A manual reset must be performed on the HMI.
  - **Freezestat RA** - When the freezestat trips, the unit will go to full return air.
  - **Low Gas Switch** - When enabled, if the pressure drops below the threshold heating will shut down.
  - **High Gas Switch** - When enabled, if the pressure rises above the threshold heating will shut down.
  - **CO Shutdown** - When enabled, if J12-6 reaches 10V, shut down the unit (blower, heating, and cooling).
  - **High Duct PS Config** - When enabled, if the duct pressure is greater than the set point for longer than the set time, heating/cooling will shut down. A fault will be displayed on the HMI.
    - **Time** - Setting for how long the unit can be outside of its pressure range.
    - **PS Lim** - Duct pressure alarm set point.
  - **Bldg PS Config** - When enabled, if the building pressure is lower/greater than the set point for longer than the set time, heating/cooling will shut down. A fault will be displayed on the HMI.
    - **Time** - Setting for how long the unit can be outside of its pressure range.
    - **Low PS Lim** - Low pressure alarm set point.
    - **High PS Lim** - High pressure alarm set point.

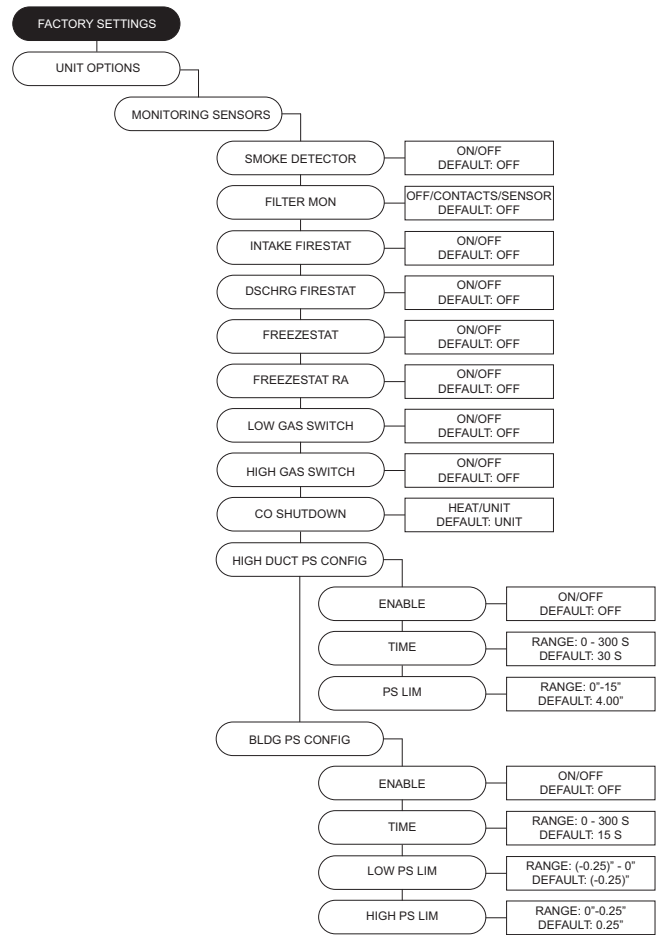

• **Mixing Box Config**

- **Mixing Box** - Off, Manual, 2 Position, Outdoor Air %, Analog Control, Pressure, CO2.
- **Mixing Box Deadband** - If the temperature difference between the outdoor and return sensor is less than or equal to this set point, the MUA Board will not attempt to adjust the output voltage until it matches the outdoor air percentage set point. This setting only takes effect when either outdoor air % or schedule is selected.
- **Return As Space** - Setting this to On will not require a space sensor or HMI. This setting will use the return air thermistor (RT) in place of the space sensor.
- **Off Position** - Allows user to select how the dampers will be positioned when the supply fan is off. Standard (default), Max Outdoor Air %, or Min Outdoor Air %.
- **Mixing Box Limits** - Minimum and maximum settings for mixing box. Percentage or voltage based on mixing box selection.
- **Preset OA Values** - If set to On, the voltage values equivalent to air percentage. Based on percentage of movement to the mixing box damper. No value may be the same.
- **Edit OA% Table** - User may edit voltages for the equivalent to outdoor air percent table.
- **Damper Presets** - This allows the user to set damper preset option On or Off.
- **Preset Volts** - Uses aux pins to control damper actuator.
- **Occ/Unocc Preset Volts** - When scheduling is On, Occ/Unocc Preset Volts will be available.
- **Intake Damper** - On/Off option for intake damper.
- **Discharge Damper** - On/Off option for discharge damper.
- **Room Override** - Uses room override SP rather than Discharge SP. This setting will only have an effect when the heat tempering mode setting is discharge and activate based on is not set to intake.
- **Exhaust Contactor** - This allows the user to assign a contactor for an interlocked exhaust fan. There are occupied and unoccupied settings.
  - **None**
  - **Before airflow** - Exhaust fan will start before the airflow proving switch has been activated.
  - **After airflow** - Exhaust fan will start after the airflow proving switch has proved there is airflow.
- **Exhaust On Smoke** - When enabled On, if it receives a 24VAC signal from a fire system, this will shut down the supply fan and enable the exhaust contactor. The 24VAC signal must originate from the MUA Board.
- **Exhaust Speed Ref** - When enabled On, the exhaust speed will match supply blower VFD.
- **Cabinet Heater** - This allows the user to enable the cabinet heater, if applicable. If enabled, the temperature sensor on MUA Board controls the cabinet heater. When this option is enabled, to adjust set points, go to **User Settings > Temp Set Points > Option Set Points > Cab Heat Set Points**.

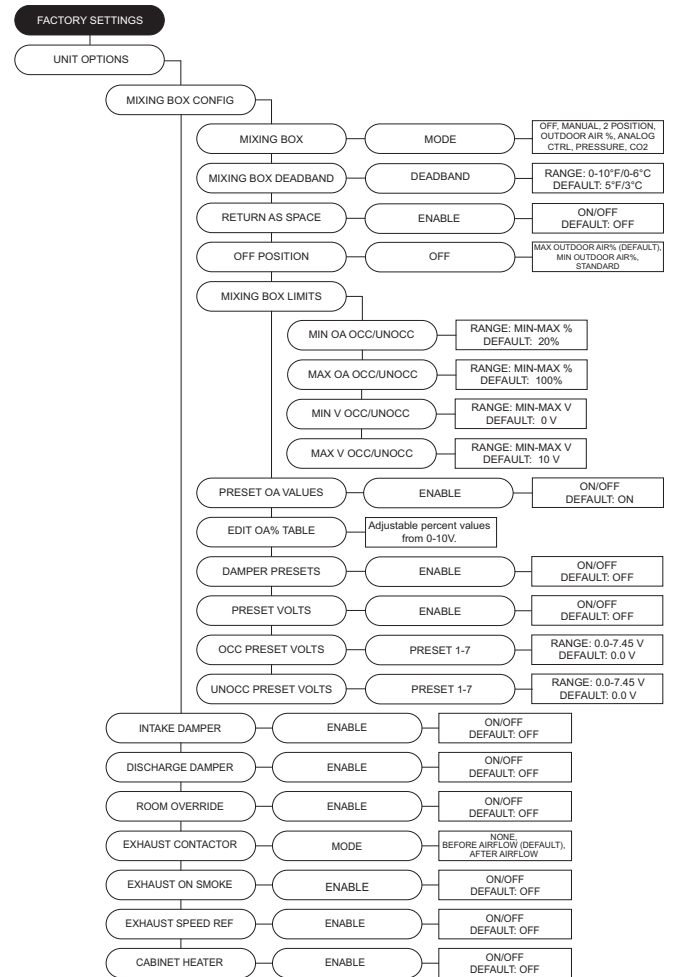

- **Blower Throttle** - The throttle function is to maintain profile pressure across the burner.
- **Throttle Volt Step** - Increases/decreases fan speed when a third party VFD is used.
- **Proof of Closure** - For gas valves that contain a proof of closure switch, the user may set this option On. Before heating occurs, a 24V AC input must be present at connector J32 pin 12.
- **No FSC Reset** - When this option is set to On, the flame safety control will not reset on a failure to prove flame. If the flame fails, a manual reset is required immediately via the push button or HMI.
- **Warm Liquid Bypass** - Prevents freezing of condensing coil in low ambient temperatures.
- **Trouble Input**
  - **Mode** - If connector J28 pin 3 receives 24 volts, the unit will act based on mode setting:
    - **Unit Off** - Shuts down blower (heating/cooling will also shutdown). Bypass any timers.
    - **Both Off** - Turns off/lockout heating and cooling. Bypass min on/off timers.
    - **Heat Off** - Turns off/lockout heating.
    - **Cool Off** - Turns off/lockout cooling. Bypass min On/Off timers.
    - **Set Back** - Forces unit to unoccupied state.
  - **Time** - Setting for off/lockout time.
- **CO2 Control Config** - Monitors CO2 and will adjust blower speed/damper position depending on CO2 set point.
  - **Override** - The unit will try to maintain space CO2 Parts Per Million (PPM) levels based on min/max threshold set points set by the user. The unit will modulate the blower/damper linearly between their corresponding min/max settings.
  - **Threshold** - CO2 Parts Per Million (PPM) maximum threshold set points for the space. When the space CO2 PPM reading exceeds the threshold setting, the blower/damper will go to their max setting.
- **Outdoor Reset** - Allows access to setting option On/Off. Below are scenarios for Outdoor Reset functionality.
  - Discharge Heat Tempering: If outside air is below OA Reset Low set point, heat will discharge to Reset Heat Discharge setting.
  - Space Heat Tempering: If outside air is below OA Reset Low set point, the space set point will adjust to Reset Heat Space setting.
  - Intake Cool Tempering: If outside air is above OA Reset High set point, cooling will go to max staging. If both evap and dx are present, unit will run all.
  - Intake Space Cool Tempering: If outside air is below OA Reset Low set point, space set point will adjust to Reset Cool Space setting.

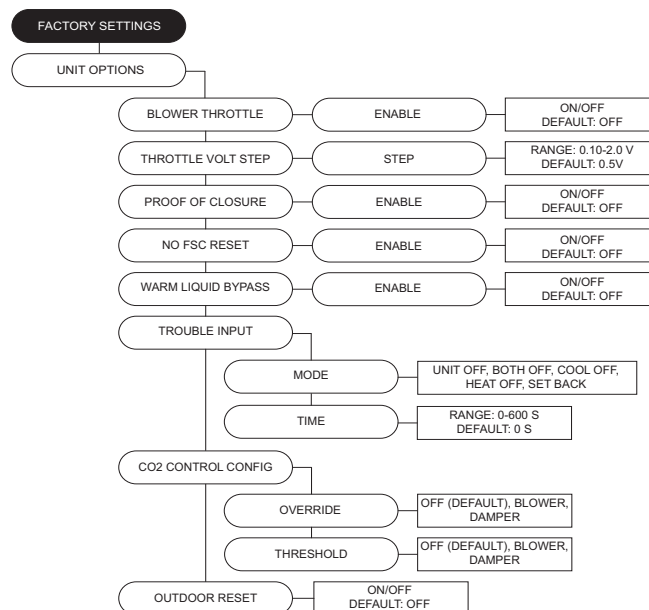

• **Dynamic Set Point** - Dynamic functionality. **For heating, every multiple of the Dynamic Set Point Differential would multiply the effect of the Dynamic Offset setting.**

- When heating: If the measured outside air temperature is below the Dynamic Heat OA set point minus the differential set point, the space or discharge set point will increase by the offset setting.
- If the measured outside air temperature is above the Dynamic Heat OA set point plus the differential set point, the space or discharge set point will decrease by the offset setting.
- When cooling: If the measured outside air temperature is below the Dynamic Cool OA set point minus the differential set point, the space or discharge set point will increase by the offset setting.
- If the measured outside air temperature is above the Dynamic Cool OA set point plus the differential set point, the space or discharge set point will decrease by the offset setting.

• **Single Zone VAV** - When set to blower, damper, or both, adjustable set points are located in User Settings.

- **Invert** - Normal operation, the blower/damper will go to max settings. Inverse operation, the blower/damper will go to min settings.

• **Alarm Output** - User may set to All or Fireeye. If All is selected, output will energize when any fault occurs. If Fireeye is selected, output will energize when Fireeye faults occur. Connector J30 pin 8 will be energized.

• **Pool Room** - Option for pool room applications.

- **Pool Room DP SP** - When above the dew point setpoint (SP), the blower will modulate to the pool room's blower speed setting.
- **PR Blower Speed** - Blower speed adjustment for high dew point pool rooms.
- **PR DP Hyst** - Hysteresis value applied to dew point SP.

• **Unit Performance** - Adjustable points for monitoring.

For service settings, go to **Service > Unit Performance**.

- **CFM** - Design CFM
- **Min/Max Duct SP** - Design duct static pressure.
- **Min/Max Bldg SP** - Design building static pressure.
- **Mtr Eff** - Motor Efficiency.
- **BHP** - Brake Horsepower.
- **D Freq** - Design Frequency.
- **D ECM** - Design Percentage.

**Occ OvrD Duration** - Length of override timer. If override is active, it can be manually stopped by pressing the end override button on the HMI.

**Limit SP Adjust** - This allows the user to change the current temperature set point through the home screen. The range adjustment is 0-100 degrees. When the set point is set to 0°F, the adjustment buttons (+/-) will not be visible.

**Temp OvrD Duration** - Length of temperature override timer.

**PID Parameters** - (DO NOT CHANGE PARAMETERS)

**Sensor Offsets** - Offset adjustment for Discharge, Space, and Intake sensor parameter settings.

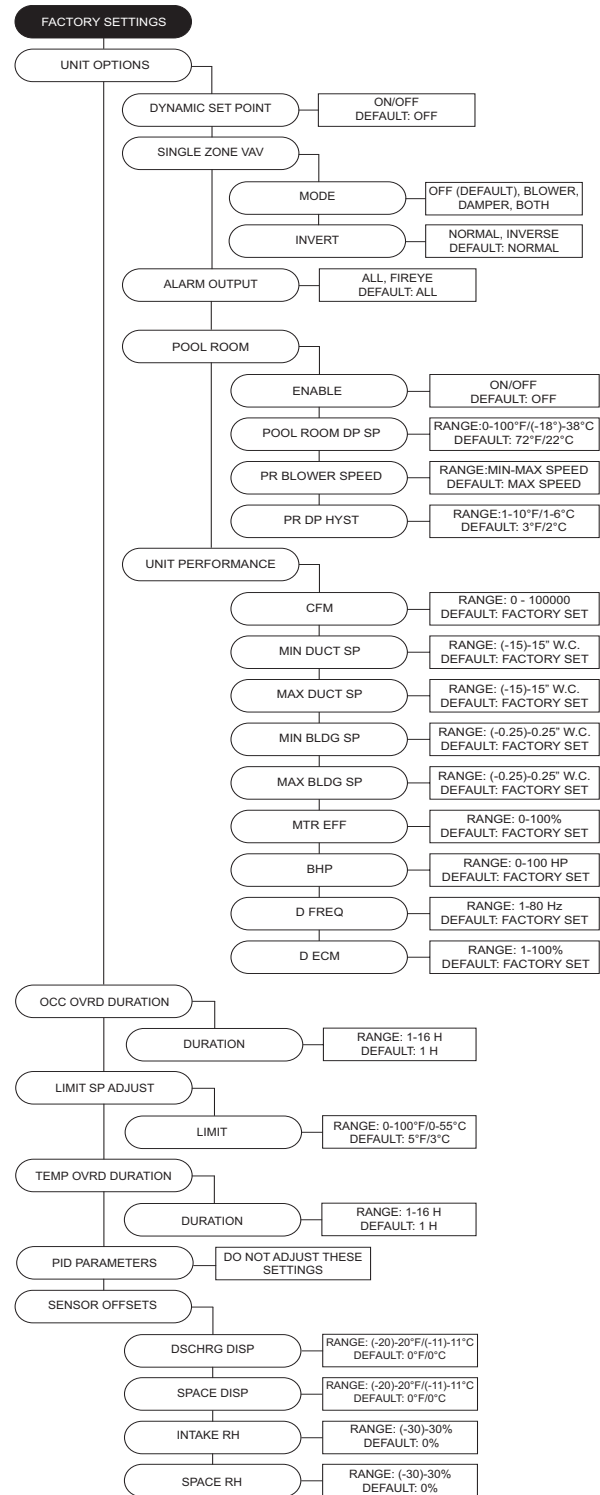



**Service** Menu Password = 1234.

**Temperatures** - Monitor various temperature values.

**Relative Humidity** - Current humidity readings per HMI.

**Open/Closed Status** - Open/closed status of all inputs.

**Variable Values** - Monitor variable input and output values.

**VFD Status** - Monitor VFD parameters.

**High Temp Limit** - Displays the high temp limit.

**Airflow Limits** - Displays the high/low airflow limits.

**Mixing Box Values** - Monitor mixing box values.

**Unit Performance** - Compares **Unit Options > Unit Performance** to current unit's operational values.

- **Dsn CFM** - Design CFM. Job specific unit CFM.
- **Act CFM** - Actual CFM. Current unit CFM reading.
- **Min/Max Dsn D SP** - Design duct static pressure. Job specific external static pressure.
- **Min/Max Dsn B SP** - Design building static pressure. Job specific external static pressure.
- **Act D SP** - Actual duct static pressure. Current external static pressure.
- **Act B SP** - Actual building static pressure. Current external static pressure.
- **Act BHP** - Actual Brake Horsepower.
- **Mtr Delta** - Motor Delta. Temperature rise caused by motor heat.
- **MHG** - Motor Heat Gain. BTU rise caused by motor heat.
- **HT Cap** - Heating capacity output in MBH.
- **HT KW** - Heating output in kilowatts.

**Test Menu** - When in a testing state, you must set the 'State' back to OFF to cancel the test.

- **Test Fans** - All, Supply, Exhaust.
- **Test Heating** - Contains high/low fire tests for stages. If "Heating Config" is set to 0, then "No Heat Stage Set" will display. Allows blower and damper modulation.
  - In test mode, the high limit setting will be based on intake temp + max temp rise + 10 degrees or the unit's high limit setting, whichever is higher.
  - If mixing box is On, set to 0V or 100% OA.
  - Exiting test mode will reset the PID.
- **Test Cooling** - Test cooling or heat pump system. Also, monitors cooling system specifications. Allows blower and damper modulation.
- **Test High Temp Limit** - Test menu allows user to set limit to simulate a high temp fault.
- **Test Options**
  - **Test Cabinet Heater** - Activates the cabinet heater on.
  - **Test Drain Heater** - Activates the drain heater to on.
  - **Test Mixing Box** - This test will create an output to the outdoor air control. The test will begin at 0 volts. The up/down buttons allow for modulation.
  - **Test Freezestat** - Access to adjust set points to verify freezestat operation in different ambient conditions.

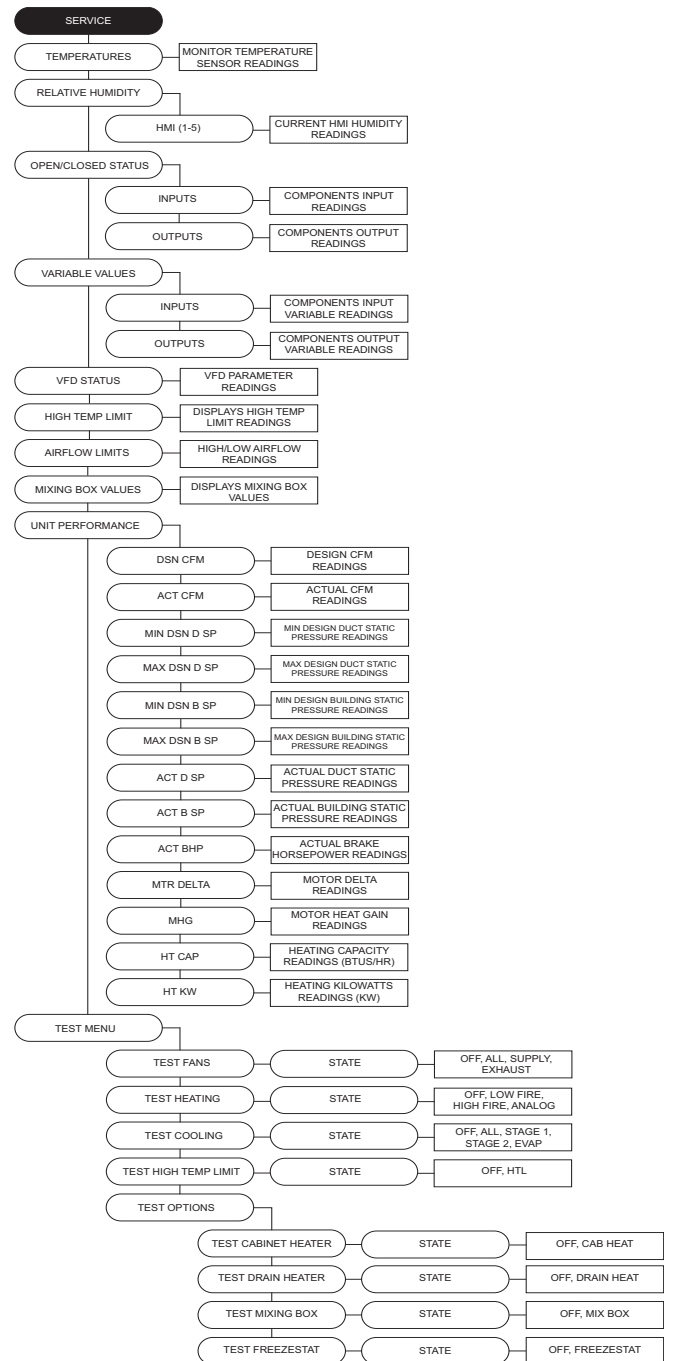

**Clear Fault History** - Clears entire fault history. If a fault is active when cleared, that fault will show up until it is fixed.

**Set Clock** - Adjustment for Day and Time settings.

**Factory Reset** - Confirming will reset to factory saved defaults, or last saved updated factory defaults.

**Update Factory Defaults (DFLTS)** - Allows original factory default settings to be overridden. Confirming the updated settings will now be used during a "Factory Reset."

**Calibrate Onboard PS** - Calibrates onboard pressure sensor. Must disconnect all pressure tubes before calibration.

**Calibrate Mixing Box** - Calibration process to update factory default values to building site conditions.

**Reset MB To Defaults** - Mixing box values reset to defaults.

**Calibrate Filter PS** - Calibrates clogged filter pressure. Must disconnect all pressure tubes before calibration.

**Cal Static Duct PS** - Calibrates static duct pressure. Must disconnect all pressure tubes before calibration.

**Cal Static Building PS** - Calibrates static building pressure. Must disconnect all pressure tubes before calibration.

**Calibrate Supply CFM** - Calibrates pressure differential in the venturi to calculate approximate fan CFM. Must disconnect all pressure tubes prior to calibration.

**Supply CFM** - Displays measured CFM readings. This readout is only valid for units with direct-drive wheels.

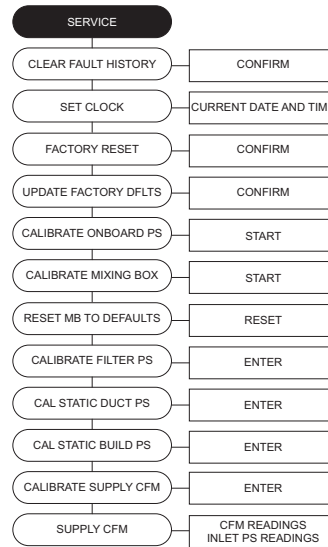



## Electronically Commutated Motor Speed Control

Electrically Commutated Motors (ECM) with speed control allow for accurate adjustments of fan speed. The benefit of EC motors is exceptional efficiency, performance, and motor life.

### External PWM Signal

The fan unit will be shipped with power wiring and communication wiring fed to an internal junction box. The fan is shipped with Shielded Twisted Pair (STP) wire, which is used for wiring to a remote PWM signal. Red wire is used to go to the positive PWM signal, and black wire is used to go to the negative PWM signal.

Reference schematics for all wiring connections. STP is connected to the communication wiring of the motor using wire nuts in the junction box. If a preset length of STP is provided, it will be connected to the junction box from the factory. Run the STP through any available knockout in the fan base.

### Motorized Intake Damper

On units shipped with the optional motorized intake damper, a power transformer is supplied with the unit if the main incoming voltage is greater than 120V. **No external wiring to the damper motor is required.**

### Variable Frequency Drive (VFD)

**WARNING!**

- Before installing the VFD drive, ensure the input power supply to the drive is OFF.
- The power supply and motor wiring of the VFD must be completed by a qualified electrician.
- The VFD is factory programmed, only change if replaced or ordered separately.

Consult the VFD manual and all documentation shipped with the unit for proper installation and wiring of the VFD. The VFD has been programmed by the factory with ordered specific parameters. Use **Table 7** as a guide during installation.

**Table 7 - VFD Installation Check List**

Check Off	Description
	The installation environment conforms to the VFD manual.
	The drive is mounted securely.
	Space around the drive meets the drive's specification for cooling.
	The motor and driven equipment are ready to start.
	The drive is properly grounded.
	The input power voltage matches the drive's nominal input voltage.
	The input power connections at L1, L2, and L3 are connected and tight. Verify correct size crimp fitting is used.
	The input power protection is installed.
	The motor's power connection at U, V, and W are connected and tight. Verify correct size crimp fitting is used.
	The input, motor, and control wiring are run in separate conduit runs.
	The control wiring is connected and tight.
	NO tools or foreign objects (such as drill shavings) are in the drive.
	NO alternative power source for the motor (such as a bypass connection) is connected - NO voltage is applied to the output of the drive.

## VFD Installation

### Input AC Power

- Circuit breakers feeding the VFDs are recommended to be thermal-magnetic and fast-acting. They should be sized based on the VFD amperage. Refer to “**ACTECH SMV VFD**” on page 52. See installation schematic for exact breaker sizing.
- Every VFD should receive power from its own breaker. If multiple VFDs are to be combined on the same breaker, each drive should have its own protection measure (fuses or miniature circuit breaker) downstream from the breaker.
- Input AC line wires should be routed in conduit from the breaker panel to the drives. AC input power to multiple VFDs can be run in a single conduit if needed. **Do not combine input and output power cables in the same conduit.**
- The VFD should be grounded on the terminal marked PE. A separate insulated ground wire must be provided to each VFD from the electrical panel. This will reduce the noise being radiated in other equipment.

**ATTENTION: Do not connect incoming AC power to output terminals U, V, W. Severe damage to the drive will result. Input power must always be wired to the input L terminal connections (L1, L2, L3).**

### VFD Output Power

- Motor wires from each VFD to its respective motor **MUST** be routed in a **separate steel** conduit away from control wiring and incoming AC power wiring. This is to avoid noise and crosstalk between drives. An insulated ground must be run from each VFD to its respective motor. Do not run different fan output power cables in the same conduit.
- VFD mounted in ECP: A load reactor should be used and sized accordingly when the distance between the VFD and motor is greater than specified below. The load reactor should be installed within 10 feet of the VFD output:
  - 208/230V** - Load reactor should be used when distance exceeds 250 feet.
  - 460/480V** - Load reactor should be used when distance exceeds 50 feet.
  - 575/600V** - Load reactor should be used when distance exceeds 25 feet.
- VFD mounted in fan: The load reactor should be sized accordingly when the VFD is mounted in the fan.
  - 208/230V** - Load reactor is optional but recommended for 15 HP and above motors.
  - 460/480V** - Load reactor is optional but recommended for 7.5 HP and above motors.
  - 575/600V** - Load reactors are required for all HP motors.
- If the distance between the VFD and the motor is extremely long, up to 1000 FT, a dV/dT filter should be used, and the VFD should be increased by 1 HP or to the next size VFD. The dV/dT filter should be sized accordingly and installed within 10 feet of the output of the VFD.
  - 208/230V** – dV/dT filter should be used when distance exceeds 400 feet.
  - 460/480V** – dV/dT filter should be used when distance exceeds 250 feet.
  - 575/600V** – dV/dT filter should be used when distance exceeds 150 feet.
- Do not install a contactor between the drive and the motor. Operating such a device while the drive is running can potentially cause damage to the power components of the drive.
- When a disconnect switch is installed between the drive and motor, the disconnect should only be operated when the drive is in a STOP state.

## VFD Programming

### Programming

1. The Drive should be programmed for the proper motor voltage. P107 is set to 0 (Low) if motor voltage is 120V AC, 208V AC or 400V AC. P107 is set to 1 (High) if the motor voltage is 230V AC, 480V AC, or 575V AC.
2. The Drive should be programmed for the proper motor overload value. P108 is calculated as Motor FLA x 100 / Drive Output Rating (refer to “**ACTECH SMV VFD**” on page 52).

#### To enter the PROGRAM mode to access the parameters:

1. Use the buttons on the VFD screen (**Figure 23**) to adjust VFD settings. Press the Mode (M) button. This will activate the password prompt (PASS).
2. Use the Up and Down buttons to scroll to the password value (the factory default password is “0225”) and press the Mode (M) button. Once the correct password is entered, the display will read “P100”, which indicates that the PROGRAM mode has been accessed at the beginning of the parameter menu.
3. Use the Up and Down buttons to scroll to the desired parameter number.
4. Once the desired parameter is found, press the Mode (M) button to display the present parameter setting. The parameter value will begin blinking, indicating that the present parameter setting is being displayed. The value of the parameter can be changed by using the Up and Down buttons.
5. Pressing the Mode (M) button will store the new setting and exit the PROGRAM mode. To change another parameter, press the Mode (M) button again to re-enter the PROGRAM mode. If the Mode button is pressed within 1 minute of exiting the PROGRAM mode, the password is not required to access the parameters. After one minute, the password must be re-entered to access the parameters again.

P500 parameter provides a history of the last 8 faults on the drive. It can be accessed without entering PROGRAM mode.

**Figure 23 - VFD Screen**

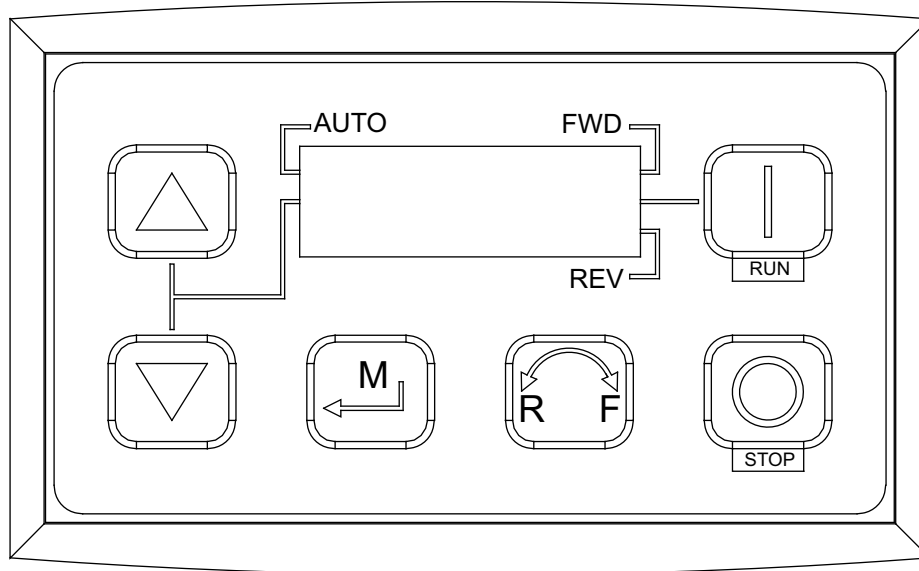

**NOTE: When a parameter is changed in the drive, the drive should be de-energized. Wait for the display to go completely dark. Once the display is completely dark, the drive can be re-energized.**

**ACTECH SMV VFD**

**Table 8 - Cross-Reference**

HP	Part Number	Volts	1Ø Input	3Ø Input	Input Amps 1Ø 120V AC	Input Amps 1Ø 240V AC	Output Amps	Breaker 1Ø 120V AC	Breaker 1Ø 240V AC
0.5	ESV371N01SXB571	120/240V	X	-	9.2	4.6	2.4	15	15
1	ESV751N01SXB571	120/240V	X	-	16.6	8.3	4.2	25	15
1.5	ESV112N01SXB571	120/240V	X	-	20	10	6	30	20

HP	Part Number	Volts	1Ø Input	3Ø Input	Input Amps 1Ø	Input Amps 3Ø	Output Amps	Breaker 1Ø	Breaker 3Ø
0.5	ESV371N02YXB571	240V	X	X	5.1	2.9	2.4	15	15
1	ESV751N02YXB571	240V	X	X	8.8	5	4.2	15	15
1.5	ESV112N02YXB571	240V	X	X	12	6.9	6	20	15
2	ESV152N02YXB571	240V	X	X	13.3	8.1	7	25	15
3	ESV222N02YXB571	240V	X	X	17.1	10.8	9.6	30	20
5	ESV402N02TXB571	240V	-	X	-	18.6	16.5	-	30
7.5	ESV552N02TXB571	240V	-	X	-	26	23	-	40
10	ESV752N02TXB571	240V	-	X	-	33	29	-	50
15	ESV113N02TXB571	240V	-	X	-	48	42	-	80
20	ESV153N02TXB571	240V	-	X	-	59	54	-	90
<b>480V</b>									
1	ESV751N04TXB571	480V	-	X	-	2.5	2.1	-	15
1.5	ESV112N04TXB571	480V	-	X	-	3.6	3	-	15
2	ESV152N04TXB571	480V	-	X	-	4.1	3.5	-	15
3	ESV222N04TXB571	480V	-	X	-	5.4	4.8	-	15
5	ESV402N04TXB571	480V	-	X	-	9.3	8.2	-	15
7.5	ESV552N04TXB571	480V	-	X	-	12.4	11	-	20
10	ESV752N04TXB571	480V	-	X	-	15.8	14	-	25
15	ESV113N04TXB571	480V	-	X	-	24	21	-	40
20	ESV153N04TXB571	480V	-	X	-	31	27	-	50
25	ESV183N04TXB571	480V	-	X	-	38	34	-	70
30	ESV223N04TXB571	480V	-	X	-	45	40	-	80
40	ESV303N04TXB571	480V	-	X	-	59	52	-	100
50	ESV373N04TXB571	480V	-	X	-	74	65	-	125
60	ESV453N04TXB571	480V	-	X	-	87	77	-	150
<b>600V</b>									
1	ESV751N06TXB571	600V	-	X	-	2	1.7	-	15
2	ESV152N06TXB571	600V	-	X	-	3.2	2.7	-	15
3	ESV222N06TXB571	600V	-	X	-	4.4	3.9	-	15
5	ESV402N06TXB571	600V	-	X	-	6.8	6.1	-	15
7.5	ESV552N06TXB571	600V	-	X	-	10.2	9	-	20
10	ESV752N06TXB571	600V	-	X	-	12.4	11	-	20
15	ESV113N06TXB571	600V	-	X	-	19.7	17	-	30
20	ESV153N06TXB571	600V	-	X	-	25	22	-	40
25	ESV183N06TXB571	600V	-	X	-	31	27	-	50
30	ESV223N06TXB571	600V	-	X	-	36	32	-	60
40	ESV303N06TXB571	600V	-	X	-	47	41	-	70
50	ESV373N06TXB571	600V	-	X	-	59	52	-	90
60	ESV453N06TXB571	600V	-	X	-	71	62	-	110

## START-UP OPERATION

Before starting up or operating the unit, verify all fasteners are secure and tight. Check the set screw in the wheel hub. With power and gas **OFF** to the unit or before connecting the unit to power, turn the fan wheel by hand. Verify it is not striking the inlet or any obstructions. If necessary, re-center.

**Special Tools Required:** Standard Hand Tools, AC Voltage Meter, Tachometer, Amperage Meter, Manometer, Differential Pressure Gauge

### Unit Start-up Procedure

1. Check all electrical connections are secure and tight.
2. For belt drive units, check pulley alignment and belt tension. Refer to “**Pulley Alignment/Proper Belt Tension**” on page 55.
3. Inspect the condition of the intake damper and damper linkage, if applicable.
4. Remove intake filters if not already installed, inspect the air stream for obstructions. Install intake filters.
5. Compare the supplied **motor voltage** with the fan’s nameplate voltage. If this does not match, correct the problem.
6. Place the external disconnect to the **ON** position to start the unit. Immediately place the disconnect switch off. **Check the rotation of the fan** with the directional arrow on the blower scroll. Reversed rotation will result in poor air performance, motor overloading and possible burnout. For units equipped with a single-phase motor, check the motor wiring diagram to change rotation. For 3-phase motors, any two power leads can be interchanged to reverse motor direction.
7. When the fan is started, observe the operation and check for any unusual noises.
8. Place the external disconnect switch back to the **ON** position. The system should be in full operation with all ducts attached. Measure the system airflow.
9. Once the proper airflow is achieved, measure and record the fan speed with a reliable tachometer. **Caution - Excessive speed will result in motor overloading or bearing failure.**
10. Measure and record the **voltage** and **amperage** to the motor. Compare with the motor’s nameplate to determine if the motor is operating under safe load conditions.

## Pulley Adjustment

The adjustable motor pulley is factory set for the RPM specified (**Table 9**). Speed can be increased by closing or decreased by opening the adjustable motor sheave. Two groove variable pitch pulleys must be adjusted to an equal number of turns open or closed. Any increase in speed represents a substantial increase in horsepower required by the unit. Motor amperage should always be checked to avoid serious damage to the motor when the speed is varied. Always torque set screws according to the torque specifications shown in **Figure 24**.

**Figure 24 - Adjustable Pulley**

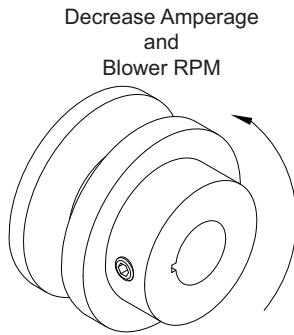

Setscrew Thread Size	Torque (in-lbs)
No. 10 (bushing)	32
1/4" (bushing)	72
5/16"	130

**Table 9 - Maximum RPM and HP Chart**

Belt Drive		
Blower Size	Max. RPM	Max. HP
10"	1800	2
12"	1500	3
15"	1400	5
18"	1200	5
20"	1000	10
25"	900	20

Direct Drive		
Blower Size	Max. RPM	Max. HP
15D	1800	2
20D	1500	3
24D	1400	5
30D	1200	5
36D	1000	10
16Z	2400	4
18Z	3200	5
20Z	2300	5
22Z	1900	5
25Z	1800	8
28Z	1400	7

## Pulley Alignment/Proper Belt Tension

- Belts tend to stretch and settle into pulleys after an initial start-up sequence. **Do not tension belts by changing the setting of the motor pulley**, this will change the fan speed and may damage the motor.
  - To re-tension belts, turn OFF power to the fan motor.
  - Loosen all fasteners that hold the blower motor plate to the blower housing.
  - Rotate the motor to the left or right to adjust the belt tension. Belt tension should be adjusted to allow 1/64" of deflection per inch of belt span. Use extreme care when adjusting V-belts as not to misalign pulleys. Any misalignment will cause a sharp reduction in belt life and produce squeaky noises. Over-tightening will cause excessive belt and bearing wear as well as noise. Too little tension will cause slippage at start-up and uneven wear.
  - Whenever belts are removed or installed, never force belts over pulleys without loosening motor first to relieve belt tension.** When replacing belts, use the same type as supplied by the manufacturer. On units shipped with double groove pulleys, matched belts should always be used.
- All fasteners should be checked for tightness each time maintenance checks are performed before restarting unit.

### Belt tension examples:

- Belt span 12" = 3/16" deflection
- Belt span 32" = 1/2" deflection

Figure 25 - Pulley Alignment/Belt Tension

- A. Belt Span Length
- B. Deflection
- C. Center Distance

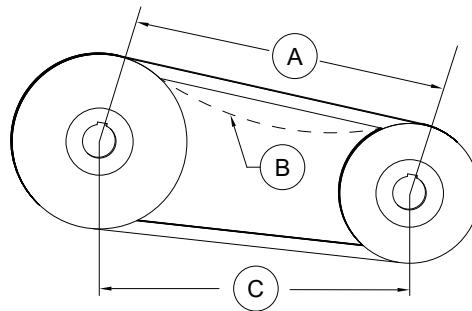

Correct

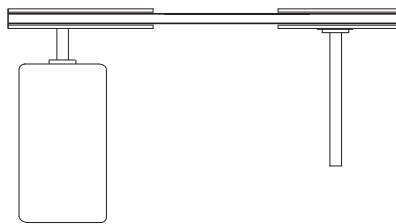

Incorrect

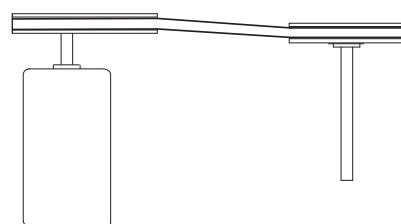

Incorrect

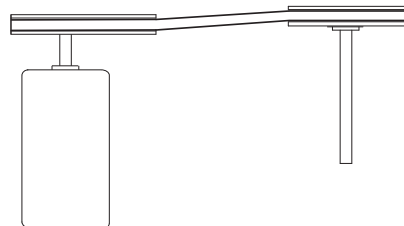

Incorrect

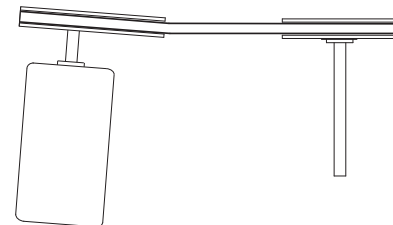





## Components

The following image and list outline the typical direct fired heater components and their functions.

**Figure 26 - Typical Cabinet Components**

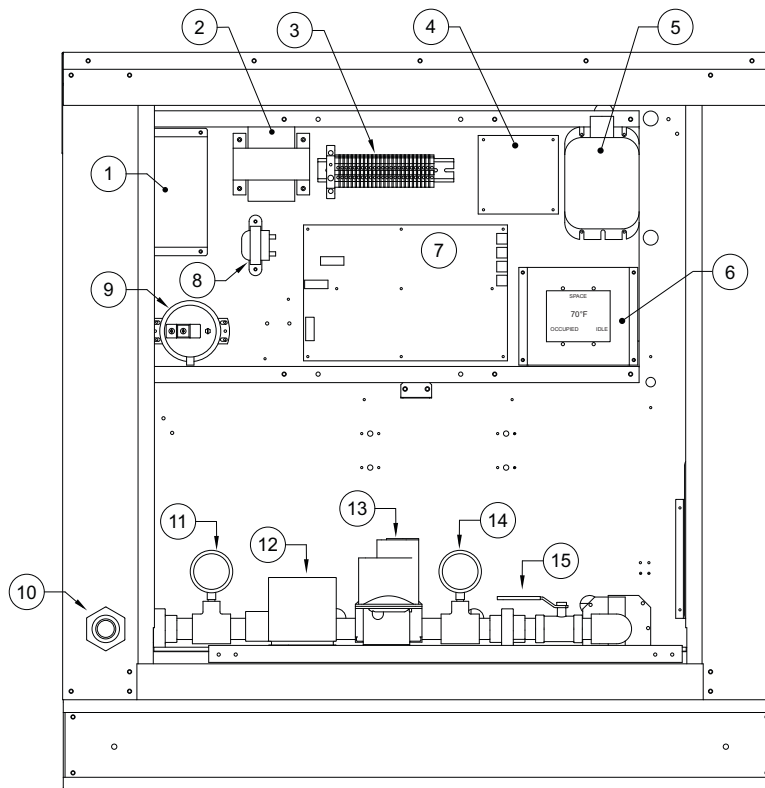

1. **VFD** – Optional component. Adjusts speed of 3-phase motors by changing the frequency signal sent to the motor.
2. **Power Transformer** – Optional component. Installed when motor voltage is greater than 120V. Used to provide 120V service to controls.
3. **Terminal Strip** – Central location to terminate control wiring. Should be used for troubleshooting.
4. **Flame Safety Control** – Initiates and monitors flame.
5. **Ignition Transformer** – Produces high voltage spark to ignite flame.
6. **HMI (Human Machine Interface) Controller** – MUA Board interface. The 4 buttons are used to navigate through the menu screens.
7. **MUA (Make-up Air) Board** – Monitors and outputs electrical signals for components and functions on the unit. Also, the MUA Board contains an airflow sensor.
8. **Transformer** – 20VA 120V to 24V.
9. **Clogged Filter Switch** – Optional component. Senses whether the filters at the intake to the main supply motor are free of dirt and contaminant.
10. **Gas Inlet** – Main gas supply connection.
11. **Inlet Gas Pressure Gauge** – Inlet gas pressure should be read from here.
12. **Combination Gas Valve** – A combination of redundant solenoid valves, pilot valve, and gas regulator built into one unit.
13. **Modulating Gas Valve** – Modulates gas flow to the burner to provide proper air temperature.
14. **Manifold Gas Pressure Gauge** – Manifold gas pressure should be read from here.
15. **Manual Gas Shut-Off Valve** – Allows gas flow to the burner to be shut off to leak-test gas train.

## Sequence of Operation

There are two main systems, a make-up air fan and a heater. The make-up air fan consists of a blower and motor. The heater may be broken down into two control systems, the Flame Safety Control (FSC) and the Modulating Gas System (MGS). The burner mixes air with the gas (Natural or LP), which heats the air.

### Flame Safety Control

The FSC is there **only** to monitor the flame, **NOT** to control the temperature. The FSC uses a flame rectification sensor mounted on the pilot assembly to detect the presence of flame in the burner.

Flame strength and presence can be measured at the FSC by reading the rectified flame signal. Use a DC voltage meter, attach meter leads to the test jacks (TP1 and TP2) on the top edge of the FSC. Flame is present when DC voltage reads between 6 and 18V DC. Ideal flame intensity produces a signal of 12V DC or higher. Flame signal may also be read on the HMI by entering **Service > Variable Values > Inputs > Flame Sensor**.

The board monitors the flame signal voltage at connector J32 pin 6 (+) and 15 (-). The FSC receives an airflow signal from the MUA Board, which tells it whether there is proper airflow through the unit (not *just* any airflow, but *proper* airflow). Proper airflow occurs when there is a 0.15" wc to 0.80" wc differential pressure drop across the burner.

When the airflow through the heater produces differential pressure in this range, the FSC indicates so by illuminating the AIRFLOW LED. The FSC controls the opening of the redundant solenoid gas valves and the operation of the spark igniter to initiate a pilot flame upon start-up.

**Figure 27 - Flame Safety Controller**

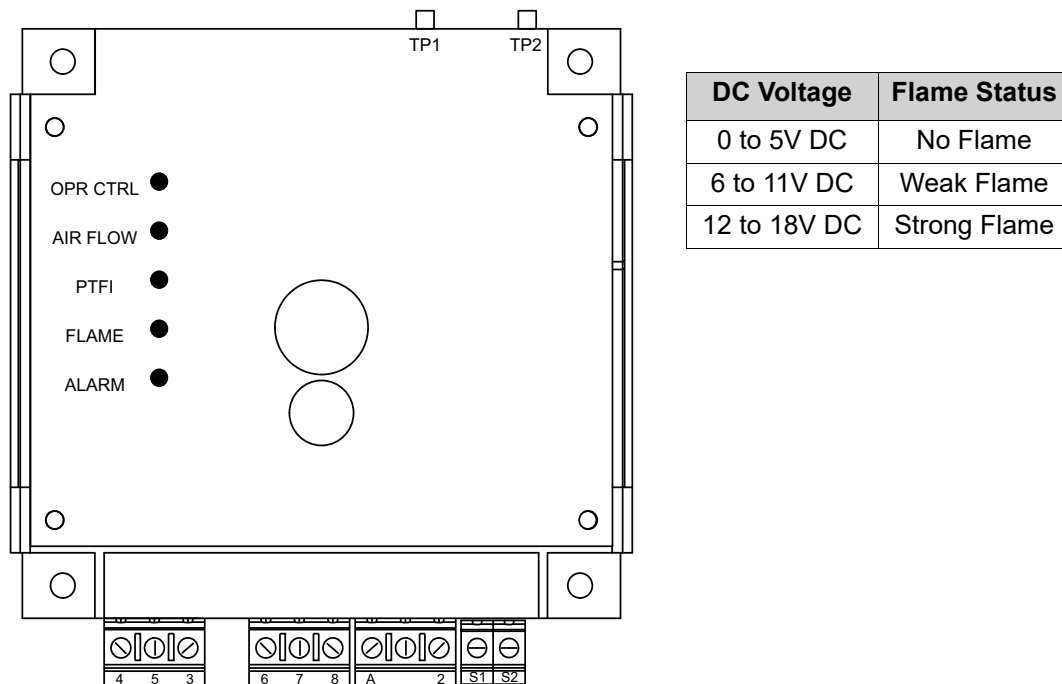

The **OPR CTRL** LED indicates that there is power to the FSC. Next, the **AIRFLOW** LED will come on if there is proper airflow through the unit. Third, the unit will pause to purge any gases or combustible vapors before attempting flame ignition. Then, there is a Pilot Trial For Ignition (PTFI), and the **PTFI** LED comes on. During PTFI, the FSC opens the pilot gas valve and allows gas to flow to the pilot assembly. At the same moment, the spark igniter is started, causing the spark to ignite the pilot gas. When the flame rod sensor detects the flame, it turns on the **FLAME** LED, turns off the PTFI LED, and powers the modulating gas system. This is the system's normal operating mode. The FSC continues to monitor the flame and airflow. Once this occurs, the unit is in the main flame cycle and thus powers the main gas valve and the modulating gas system. This is the normal operating mode. The FSC continues to monitor the flame and airflow.

The last LED on the FSC is the **ALARM** LED. The alarm will turn on when the FSC determines an unsafe condition has occurred and will not allow the unit to recycle for heat until it has properly been reset. Anytime the FSC goes into "Alarm" mode, the issue must be diagnosed and corrected to avoid further lockouts after resetting. If the unit fails to light the first time, the unit will try one more time before locking out. This retry will not occur if the No FSC reset option is enabled. To begin troubleshooting, or to reset the FSC, refer to "**Resetting Unit**" on page 71.

**Figure 28 - Proper Spark Gap**

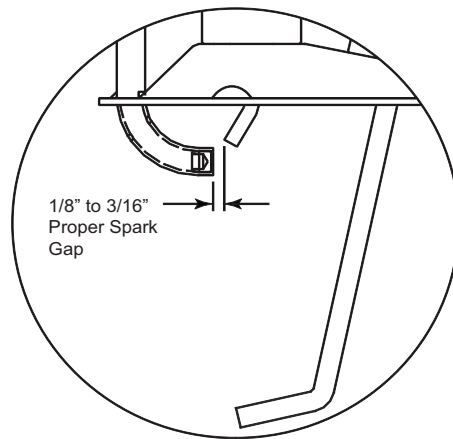

## Modulating Gas System

The Maxitrol Modulating Gas System is directly controlled from the MUA (Make-Up Air) Board at connector J32 pin 7(+) and 16(-). A modulating 0-24V DC signal is utilized to modulate the gas valve signal. The signal is a 16 kHz full-wave rectified signal.

The RTC Modulating Gas System is directly controlled from the MUA Board at connector J7 pin 6. A modulating 2-10V DC signal is utilized to modulate the gas valve signal.

The Modulating Gas System consists of an Intake Temp Sensor, a Discharge Temp Sensor, a Space Temp Sensor (only on space temperature control options), and modulating gas valve(s). The intake air sensor, the space sensor, or a combination of the two can be used to give a call for heat signal to the MUA Board.

The MUA Board uses a PID loop and checks the difference between the temperature sensor readings in order to modulate the heat appropriately.

- For kitchen MUA heating applications, intake air set point should be set at 45°F, whereas the discharge set point should be set at 55°F. The defaults may be adjusted per field conditions.
- For all other applications, the set point should be set appropriately based on end-user preferences and on-site conditions.

## High Temperature Limit

One of the backup safety devices is the high-temperature limit lockout. This temperature sensor measures the temperature inside the unit, downstream of the burner. If the factory-set temperature of 170°F is exceeded, it will signal the FSC to turn off the burner. This requires a manual reset of the high-temperature limit. Refer to “**Resetting Unit**” on page 71.

## Pilot Adjustment

1. Restart the fan and check the gas supply pressure at the inlet gas gauge upstream of all electronic valves. The inlet pressure should be **7 - 14 inches wc (7 inches wc - 5 psi on Size 4-5 heaters)**. If the inlet pressure is too high, install an additional pressure regulator external to the unit.
2. Open the field-installed manual gas shut-off valve.
3. Close the ball valve located inside the cabinet.
4. Call for heat using the HMI **Service > Test Menu > Test Heating > High Fire**. If the pilot does not light, purge the pilot line. If air purging is required, disconnect the pilot line at the outlet of the pilot valve.
5. Check the **pilot flame voltage** on the HMI. The voltage reading should be **12V-15V DC**. The Flame LED on the Flame Safety Controller should be illuminated too. A weak pilot flame can be caused by low gas pressure or a dirty pilot orifice.
6. To adjust the pilot flame, remove the cap from the pilot adjustment screw on the combination gas valve, refer to **Figure 12**. Increase the pilot gas flow by turning the screw counter-clockwise. Decrease the pilot gas flow by turning the screw clockwise. The flame signal voltage should read **12V-15V DC** on the HMI under **Service > Test Menu > Test Heating**.
7. Once the pilot has been established, open the main manual gas shut-off valve downstream of the electronic valves. Verify the main gas valve opens and gas flows to the burner.

**Figure 29 - Pilot Assembly**

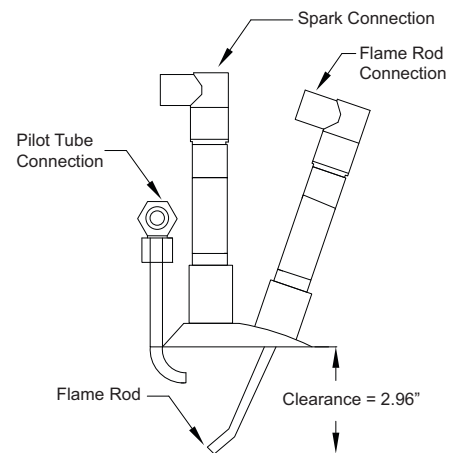

## Main Burner Adjustment (Maxitrol Valve)

- Once the pilot has been properly established, the manifold gas pressure or temperature rise should be adjusted to nameplate or design specifications. The gas pressure regulator is adjusted at the factory for average gas conditions. It is important that the gas supplied to the burner is in accordance with the input rating on the rating plate. Refer to **“Gas Train” on page 15**.
  - For size 1-3 heaters, the gas pressure regulator is integral to the combination gas valve.
  - For size 4-5 heaters, the gas pressure regulator is located on the modulating valve.
- Use the service test menu to lock the unit in high fire: **Service > Test Menu > Test Heating > State > High Fire**. Press Enter.
- The manifold pressure should be checked at the pressure gauge downstream of the modulating valve. **Figure 32 on page 63** indicates the proper manifold pressure for the desired amount of BTUs per foot of burner. For natural gas systems, the high fire manifold pressure should not exceed **5 inches wc**. For propane gas, the high fire manifold pressure should not exceed **2.5 inches wc**. Another method of checking high fire is to measure the temperature rise of the unit. The temperature rise should be set to design specifications and typically is minimum 70°F.
- Every unit has a specific design manifold gas pressure based on CFM and temperature rise. Refer to the unit's nameplate for the design manifold gas pressure.
- For size 1-3, remove the cap from the combination gas valve for regulator adjustment. For size 4/5, remove the cap from the modulating valve (location #1 **Figure 12**).
- Use the regulator pressure adjusting screw to adjust the high fire manifold pressure to design temperature rise (**5 inches wc** maximum for natural gas and **2.5 inches wc** maximum for propane gas). High fire should be set to generate the design temperature rise. If the high fire screw is at the end of its adjustment and more pressure is needed, then adjust the main building gas pressure regulator spring (located external to the unit) to achieve the proper manifold pressure. Turning the regulator screw clockwise will increase pressure and counter-clockwise will decrease pressure. **Remember - The high fire DC voltage should read 12V-18V on the HMI.**
- Use the service test menu to lock the unit in low fire: **Service > Test Menu > Test Heating > State > Low Fire**. Press Enter.
- Verify that the unit is in low fire by confirming the voltage to the modulating valve is 0V DC.
- Locate the bypass screw (under the cap of the valve - location #1, or side of the modulating valve - location #2), refer **Figure 12**.
- Adjust the low fire manifold pressure until there is a very thin flame along the entire length of the burner. No dark spots should be seen in the burner. If the flame is too large at low fire, this will decrease the unit's turndown ratio.
- The burner may be observed through the view-port located on the external wall of the heater. Replace the cap to the valve. Make sure all wiring and gas components are connected and operational.
- A final gas leak check shall be performed to verify the gas-tightness of the heater's components and piping under normal operating conditions. This can be done by measuring the gas pressure at the 1/4" gas plug just downstream of the modulating valve.

**Figure 30 - High/Low Fire Bypass Screw Setting**

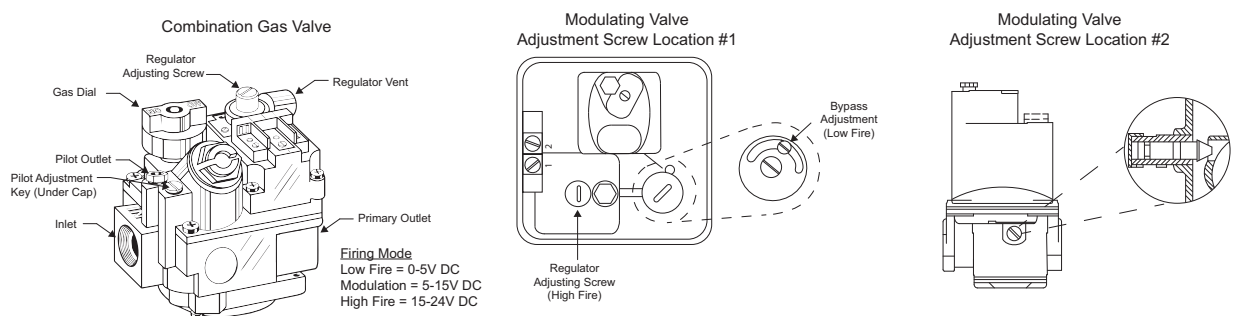

## Main Burner Adjustment (RTC Valve)

1. Once the pilot has been properly established, the manifold gas pressure or temperature rise should be adjusted to nameplate or design specifications. The gas pressure regulator is adjusted at the factory for average gas conditions. It is important that the gas supplied to the burner is in accordance with the input rating on the rating plate. Refer to **“Gas Train” on page 15**. For size 1-3 heaters, the gas pressure regulator is integral to the combination valve.
2. Use the service test menu to lock the unit in high fire: **Service > Test Menu > Test Heating > State > High Fire**. Press Enter.
3. The manifold pressure should be checked at the pressure gauge downstream of the modulating valve. **Figure 32 on page 63** indicates the proper manifold pressure for the desired amount of BTUs per foot of burner. For natural gas systems, the high fire manifold pressure should not exceed **5 inches wc**. For propane gas, the high fire manifold pressure should not exceed **2.5 inches wc**. Another method of checking high fire is to measure the temperature rise of the unit. The temperature rise should be set to design specifications and typically is minimum 70°F.
4. Every unit has a specific design manifold gas pressure based on CFM and temperature rise. Refer to the unit’s nameplate for the design manifold gas pressure.
5. For size 1-3, remove the cap from the combination gas valve for regulator adjustment.
6. Use the regulator pressure adjusting screw to adjust the high fire manifold pressure to design temperature rise (**5 inches wc** maximum for natural gas and **2.5 inches wc** maximum for propane gas). High fire should be set to generate the design temperature rise. If the high fire screw is at the end of its adjustment and more pressure is needed, then adjust the main building gas pressure regulator spring (located external to the unit) to achieve the proper manifold pressure. Turning the regulator screw clockwise will increase pressure, and counter-clockwise will decrease pressure.
7. Use the service test menu to lock the unit in low fire: **Service > Test Menu > Test Heating > State > Low Fire**. Press Enter.
8. Verify that the unit is in low fire by confirming the voltage to the modulating valve is 2V DC.
9. Go to **Factory Settings > Heating Config > Gas Valve Limits > Min%** to adjust the low fire voltage.
10. Adjust the low fire manifold pressure until there is a very thin flame along the entire length of the burner. No dark spots should be seen in the burner. The burner may be observed through the view-port located on the external wall of the heater. Make sure all wiring and gas components are connected and operational.
11. A final gas leak check shall be performed to verify the gas-tightness of the heater’s components and piping under normal operating conditions. This can be done by measuring the gas pressure at the 1/4” gas plug just downstream of the modulating valve.

**Figure 31 - RTC Modulating Gas Valve**

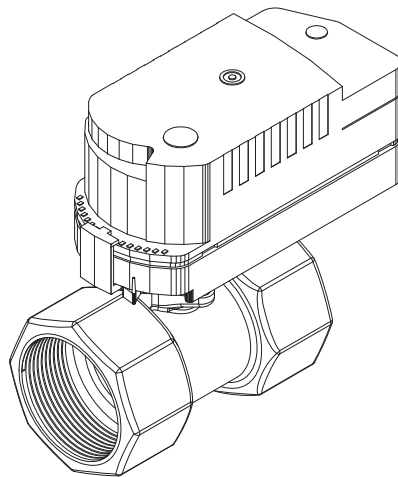

**Figure 32 - Pressure vs. Firing Rate**

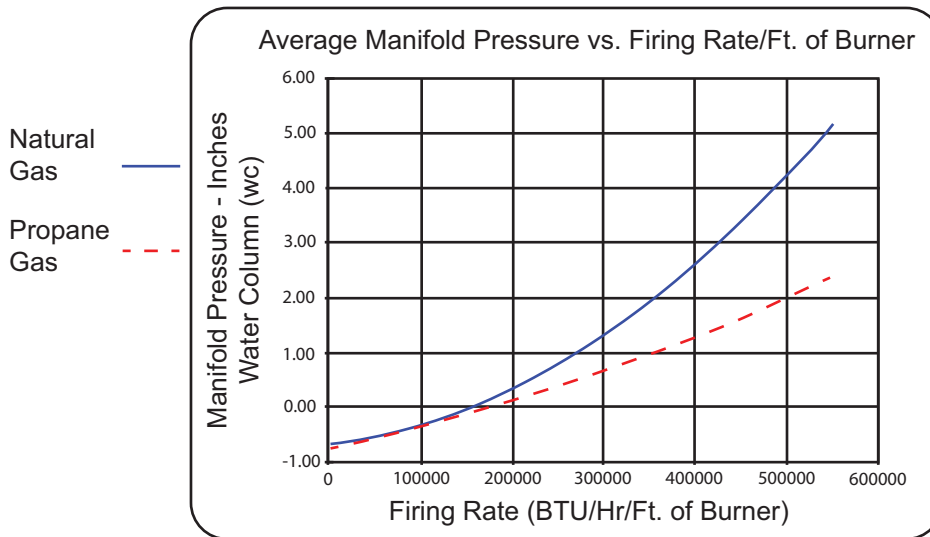

### Final Start-up Procedure

1. With the air and burner systems in full operation and all ducts attached, measure the system airflow. For belt drive units, the motor sheave (pulley) is variable pitch and allows for an increase or decrease of the fan RPM. If an adjustment is needed, refer to **“Pulley Adjustment” on page 54**. Reference **Table 9 on page 54** and **“Pulley Combination Chart” on page 56** for adjustment specifications.
2. Once the proper airflow is achieved, measure and record the fan speed with a reliable tachometer. **Caution - Excessive speed will result in motor overloading or bearing failure.**
3. Measure and record the **voltage** and **amperage** to the motor and compare with the motor nameplate to determine if the motor is operating under safe load condition.
4. For belt drive units, once the rpm of the wheel has been properly set, disconnect power. Recheck belt tension and pulley alignment, refer to **Figure 25 on page 55**.

## Airflow Sensor

The MUA Board contains an onboard pressure sensor (**Figure 33**) for airflow monitoring. There are both high and low **airflow tubing connections** connected to a sensor, measuring the pressure drop across the burner. This is to verify that there is proper airflow (**0.15 to 0.80 inch wc**) across the burner and proper combustion at all times.

There are two airflow tubes in the heater, located near the burner and profile plate assembly (profile plates surround the burner and control air into the burner section).

In the case of a broken belt, clogged filters, blocked intake, excessive duct or static pressure, the correct burner differential pressure may not be achieved. This will prevent the low airflow sensor to close. The airflow sensor protects against profile plate failures that cause excessive airflow through the burner. In the event that the pressure drop across the burner is not in the range of the airflow sensor, gas flow to the burner is stopped by the Flame Safety Control.

**NOTE: With the blower running, verify the airflow pressure reading is a positive value. Reverse the airflow tubes if the reading is negative.**

To view burner profile pressure on the HMI, go to **Service > Variable Values > Inputs > Onbd Prof PS**.

**Figure 34** illustrates the approximate CFM going through the unit vs. the differential pressure measured by the airflow switch. Simply measure the differential profile pressure drop at the airflow tubes in the unit and match that value up to the unit curve. This will show the CFMs traveling through the burner and will indicate proper airflow or airflow problems (too much or not enough).

**Figure 33 - Board Airflow Sensor**

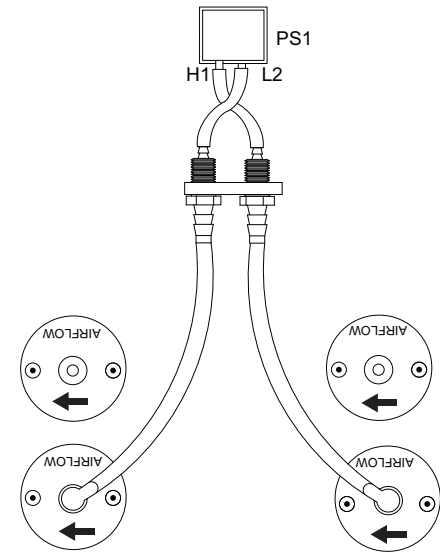

**Figure 34 - CFM Chart**

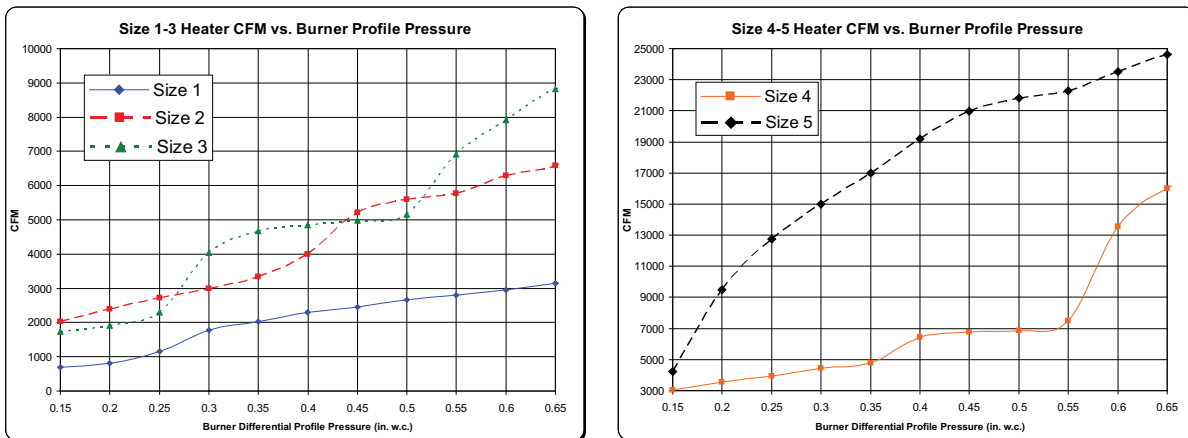



## Static Pressure Sensor Installation

For indoor mounted units using pressure control, the A-306 kit (**Figure 35**) should be used for sensing outside pressure. Use the installation instructions shipped with the sensor kit for installation guidance.

**Figure 35 - A-306 Sensor**

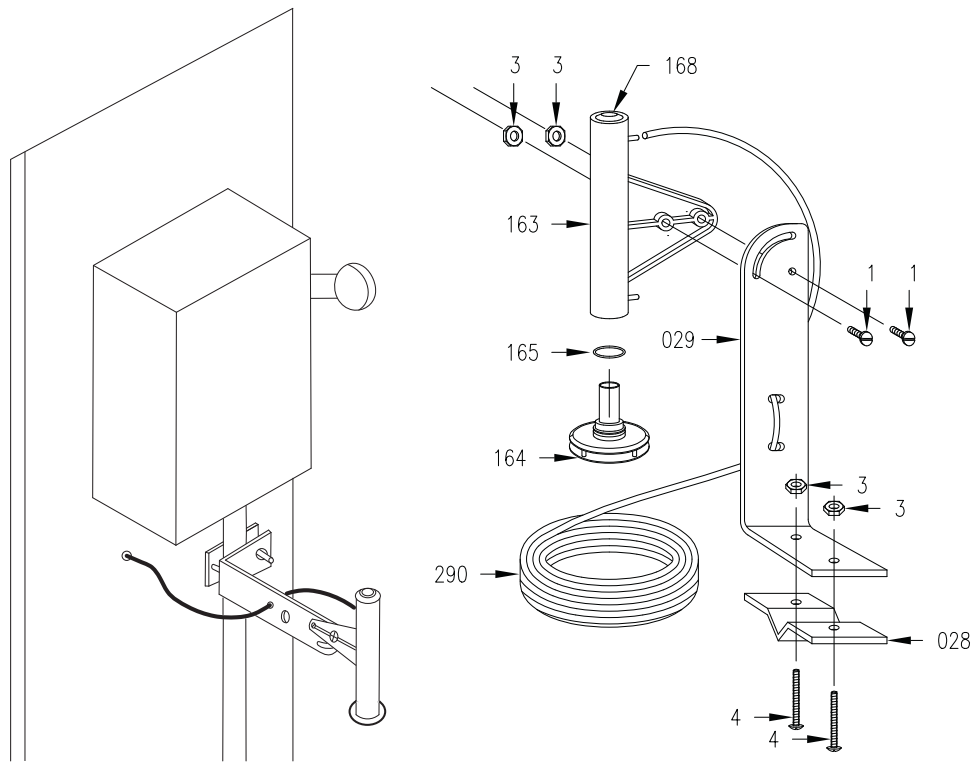

Item Number	Description
1	10-32 x 1/2" Machine Screw (2)
3	10-32 Nut (4)
4	10-32 x 1-3/4" Machine Screw (2)
028	Antenna Clamp
029	Mounting Bracket
163	Pick Up Body
164	Static Pressure Plates
165	"O" Ring Seal
168	Hole Plug
290	Tubing - 50'

# TROUBLESHOOTING

The troubleshooting section lists causes and corrective actions for possible problems with the equipment. Review this section prior to consulting the manufacturer.

## Airflow Troubleshooting Chart

Problem	Potential Cause	Corrective Action
Fan Inoperative	Blown fuse/Open circuit breaker	Check amperage.
		Check fuse, replace if needed.
		Check circuit breaker.
	Disconnect switch in "OFF" position	Place switch to the "ON" position.
	Incorrect wiring to motor	Inspect motor wiring. Verify connections with wiring diagram located on fan motor.
Motor starter overloaded		Check amperage.
		Reset starter.
Motor Overload	Incorrect fan rotation	Verify that the fan is rotating in the direction shown on rotation label.
	Fan speed is too high	Reduce fan RPM.
	Incorrect wiring to motor	Inspect motor wiring. Verify connections with wiring diagram located on fan motor.
	Overload in starter set too low	Set overload to motor's FLA value.
	Motor HP too low	Determine if HP is sufficient for job.
	Duct static pressure lower than design	Reduce fan RPM.
Insufficient Airflow	Incorrect fan rotation	Verify that the fan is rotating in the direction shown on rotation label.
	Poor outlet conditions	Check duct and connections. There should be a straight duct connection to the outlet.
	Intake damper not fully open	Inspect damper linkage. If the linkage is damaged, replace damper motor.
	Duct static pressure higher than design	Check ductwork. Adjust/resize to eliminate or reduce duct losses.
	Blower speed too low	Increase fan RPM. Do not overload motor.
	Supply grills or registers closed	Open/Adjust.
	Dirty/clogged filters	Clean filters. Replace filters if they cannot be cleaned or are damaged.
Excessive Airflow	Blower speed too high	Reduce fan RPM.
	Filters not installed	Install filters.
	Duct static pressure lower than design	Reduce fan RPM.
Excessive Vibration and Noise	Damaged/Unbalanced wheel	Replace wheel.
	Fan is operating in unstable region of fan curve	Refer to performance curve for fan.
	Bearings need lubrication/Damaged bearing	Lubricate bearings, replace if damaged.
	Fan speed is too high	Reduce fan RPM.
	Dirty/oily belt(s)	Clean belt(s).
	Belt(s) too loose	Adjust, replace if necessary.
	Worn belt(s)	Replace belt(s).
	Misaligned pulleys	Align pulleys.

## Burner Troubleshooting

Problem	Potential Cause	Corrective Action
Pilot Does Not Light/Stay Lit	Main gas is off	Open main gas valve.
	Air in gas line	Purge gas line.
	Dirt in pilot orifice	Clean orifice with compressed air.
	Gas pressure out of range	Adjust to proper gas pressure.
	Pilot valve is off	Turn pilot valve on.
	Leak at pilot orifice	Tighten pilot orifice.
	Excessive drafts	Redirect draft away from unit.
	Safety device has cut power	Check limits and airflow sensor.
	Dirty flame sensor	Clean flame sensor.
	Defective flame rod	Replace flame rod.
	No call for heat	Adjust heat set point.
	No spark at igniter	Check wiring, sensor, and ignition controller. Check spark gap, refer to <b>Figure 28 on page 59</b> .
Main Burner Does Not Light (Pilot is lit)	Defective valve	Replace combination valve.
	Loose valve wiring	Check wiring to valve.
	Shut-off valve closed	Open shut-off valve.
	Defective flame safety controller	Replace flame safety controller.
	Pilot fails as main gas valve opens, and main gas flows.	Plug the first burner port next to the pilot gas tube with burner cement.
Not Enough Heat	Main gas pressure too low	Increase main gas pressure - do not exceed 14 inches wc inlet pressure (5 PSI on size 4-5 heater).
	Too much airflow	Decrease airflow if possible.
	Burner undersized	Check design conditions.
	Gas controls not wired properly	Check wiring.
	Heat set point too low	Increase heat set point.
	Faulty HMI Sensor	Replace HMI.
	Faulty Discharge Sensor	Check wiring. Replace sensor.
	Unit locked into low fire	Check wiring.
Too much heat	Defective modulating gas valve	Check/replace modulating valve.
	Heat set point too high	Decrease heat set point.
	Unit locked into high fire	Check wiring.
	Faulty HMI Sensor	Replace HMI.
	Faulty Discharge Sensor	Check wiring. Replace sensor.

## HMI Fault Codes

Fault	Potential Cause	Corrective Action
Fire Detect	The board is receiving an input from the fire detector.	Possible fire present.
		Check wiring. Repair broken or loose wiring connections.
		Faulty fire detector, replace fire detector.
Smoke Detect	The board is receiving an input from the smoke detector.	Possible smoke detected in the system.
		Verify the smoke detector functionality.
		Check wiring. Repair broken or loose wiring connections.
		Faulty smoke detector, replace smoke detector.
Supply Overload/ Exhaust Overload	Motor overload has tripped.	Check motor for debris.
		Check contactor/motor wiring connections.
		Check overload reset button.
		Check overload amperage setting.
		Check motor bearings.
Master ROM CRC	Software mismatch.	Contact technical support.
Flame Lockout	The Flame Safety Control (FSC) verifies that airflow is sensed by the airflow sensor.	Verify spark gap. Refer to <b>Figure 28 on page 59</b> .
		Faulty flame rod.
		Faulty FSC, replace FSC.
Max FSC Cycles Fault	FSC cycles on and off greater than 20 times in 60 minutes.	Verify heating activation, check for faulty Space/ Intake/Discharge sensor.
Intake Firestat	Intake temperature exceeds the firestat set point.	Inspect intake area of the unit for unexpected heat source.
		Reset fault with HMI.
Discharge Firestat	Discharge temperature exceed the firestat set point.	Check for faulty regulators or modulating valves.
		Reset fault with HMI.
		Inspect discharge area of the unit for unexpected heat source.
Freezestat	The discharge temperature was below the freezestat temperature set point for the duration of the freezestat timer set point.	Check gas pressure.
		Check for proper burner firing.
		Check discharge sensor values. Go to <b>Service &gt; Temperatures&gt; Discharge</b> .
		Reset fault with HMI.
High Temp Limit	Unit discharge temperature exceeds maximum limit.	Check for proper airflow.
		Measure discharge sensor (ohm reading should be 10k @ 77°F).
Fireye Alarm	Fireye detected improper burner operation.	Gas is off, turn gas on.
		Faulty ignition transformer, replace transformer.
		Faulty Fireye, replace Fireye.
		Improper flame/lighting, refer to <b>“Burner Troubleshooting” on page 67</b> .
Fireye Main	Output signal is lost between the Fireye and main gas valve during heating operation.	Check wiring between connector J30-5 to Fireye. Repair broken or loose wiring connections.
		Check wiring between connector J30-6 to the main gas valve. Repair broken or loose wiring connections.

Fault	Potential Cause	Corrective Action
Gas High PS	The board lost input on the gas pressure high terminal. There should be an input when gas pressure is at the proper level.	Adjust regulator or add regulator.
		Check wiring. Repair broken or loose wiring connections.
		Faulty high pressure gas switch, replace the switch.
Gas Low PS	The board lost input on the gas pressure low terminal. There should be an input when gas pressure is at the proper level.	Check wiring. Repair broken or loose wiring connections.
		Faulty low pressure gas switch, replace the switch.
CO Alarm	The board is receiving an input from the CO detector.	Check for proper exhaust ventilation.
		Check wiring. Repair broken or loose wiring connections.
		Faulty CO detector, replace CO detector.
Evap Water PS	Drain Closed - Water pressure should be present. The board should not receive 120VAC. A fault will occur if 120VAC is present for 5 seconds.	Verify freeze protection kit is installed. Check freeze protection kit is operational.
	Drain Open - Water pressure should not be present. The board should receive 120VAC. A fault will occur if 120VAC is not present for 15 seconds.	
Evap Float	Input signal from the evap float switch lost.	Check wiring. Repair broken or loose wiring connections.
		Clogged drain.
		Faulty float switch, replace switch.
DX Float	Input signal from the drain pan float switch lost.	Make sure the pan drain is clear and water is draining.
		Check wiring. Repair broken or loose wiring connections.
		Faulty float switch, replace the switch.
Supply VFD Comm	Modbus communication fault.	Check Modbus wiring and connections.
		Verify Modbus address.
		Verify Min and Max settings of the VFD to the MUA Board settings. Go to <b>Factory Settings &gt; Unit Options &gt; Blower Config &gt; VFD Freq Limits</b> .
Modbus Fault VFD/MS #	VFD or MSC not connected or powered properly.	Check Modbus connections.
		Verify Modbus address is correct on VFD or MSC.
Door Interlock	Safety feature that will shut down supply fan when door signal lost.	Verify door is closed.
		Check wiring. Repair broken or loose wiring connections.
		Faulty door switch, replace the switch.
Intake Damper End/ Discharge Damper End	End limit input not received.	Check wiring. Repair broken or loose wiring connections.
		Board damper output/input failed.
		Faulty damper, replace damper.

Fault	Potential Cause	Corrective Action
Supply (Blower) Air Proving	Airflow proving pressure value is less than 0.05" w.c.	Kinked/blocked/damaged hose.
		Blockage in duct.
		Confirm proper CFM.
		Faulty airflow sensor, replace sensor.
		Burner profile pressure out of range.
Low PS Fault	Profile pressure is less than low profile pressure setpoint, but greater than lower pressure limit (0.05" w.c.).	Adjust profile pressure. <b>Factory Settings &gt; Unit Options &gt; Blower Config &gt; Air Profile Limits.</b>
		Increase blower speed.
High PS Fault	Profile pressure is greater than high profile pressure setpoint.	Adjust profile pressure. <b>Factory Settings &gt; Unit Options &gt; Blower Config &gt; Air Profile Limits.</b>
		Decrease blower speed.
Clogged Filter	Input for clogged filters activated.	Clean or replace filters.
		Check clogged filter switch adjustment.
		Faulty switch, replace switch.
Missing Sensor Intake/ Discharge/Space/ Outside Air/Return	When a sensor is not wired or there is an open circuit.	Check wiring. Repair broken or loose wiring connections.
		Install missing sensor.
		Replace faulty sensor.
Broken Sensor Intake/ Discharge/Space/ Outside Air/Return	Sensor or wiring shorted to ground.	Check wiring. Repair grounded wiring.
		Faulty sensor, replace sensor.
Broken Pressure Sensor	Pinched/missing airflow tubing. Faulty airflow sensor.	Check tubing at the airflow pressure sensor on the MUA Board. Refer to " <b>Board Airflow Sensor</b> " on page 64.
RTC 1 Temp Sensor	Real-Time Clock (RTC) temperature sensor located on MUA Board.	Verify there is no damage to the MUA Board or the wiring to the MUA Board.
HMI Temp Invalid	HMI internal temperature sensor readings incorrect.	Replace HMI.
Proof of Closure	Input not received when there is a call for heat.	Check wiring. Repair broken or loose wiring connections.
		Faulty gas valve, replace gas valve.
Low Flame Voltage	The board is receiving poor flame voltage signal.	Check wiring. Repair broken or loose wiring connections.
		Improper flame. Adjust pilot and low fire settings.
		Faulty Fireeye, replace Fireeye.
Communication Fault - Check Configuration	HMI communication fault or software setting.	Improper software setting. If more than one HMI is installed, check all HMIs.
HMI MB Comm		Faulty Cat 5 cable, replace cable.
		Faulty HMI, replace the HMI.
CO2 Override	High source of CO2, above PPM threshold.	Check for proper exhaust ventilation.

## VFD Fault List

Refer to VFD manufacturer manual for further details.

Fault Number	Description
0	No Fault
1	IGBT Temperature Fault
2	Output Fault
3	Ground Fault
4	Temperature Fault
5	Flying Start Fault
6	High DC BUS
7	Low DC BUS
8	Overload Fault
9	OEM Fault
10	Illegal Setup Fault
11	Dynamic Brake Fault
12	Phase Lost
13	External Fault
14	Control Fault
15	Start Fault
16	Incompatible Parameter Set
17	EPM Hardware Fault
18 - 27	Internal Fault
28	Remote Keypad Lost
29	Assertion Level Fault
30 - 33	Internal Fault
34	Comm. Module Failure
35 - 44	Network Fault

## Resetting Unit

If the flame safety control is locked out (alarm light on), reset the unit by:

1. Press the FSC Reset push-button, refer to **Figure 36**. If pressing the reset fails, continue to step 2.
2. Turn OFF power to the unit.
3. Turn power to the unit back ON.

**Figure 36 - Reset Buttons (MUA Board)**

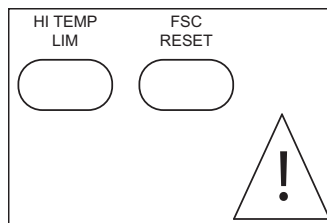

## MAINTENANCE

To guarantee trouble-free operation of this heater, the manufacturer suggests following these guidelines. Most problems associated with fan failures are directly related to poor service and maintenance.

Please record any maintenance or service performed on this fan in the documentation section located at the end of this manual.

**WARNING: DO NOT ATTEMPT MAINTENANCE ON THE HEATER UNTIL THE ELECTRICAL SUPPLY HAS BEEN COMPLETELY DISCONNECTED AND THE MAIN GAS SUPPLY VALVE HAS BEEN SHUT OFF.**

### General Maintenance

- Fan inlet and approaches to ventilator should be kept clean and free from any obstruction.
- All fasteners and electrical connections should be checked for tightness each time maintenance checks are performed before restarting unit.
- These units require very little attention when moving clean air. Occasionally oil and dust may accumulate, causing imbalance. If the fan is installed in a corrosive or dirty atmosphere, periodically inspect and clean the wheel, inlet, and other moving parts to ensure smooth and safe operation.
- Motors are normally permanently lubricated. **Caution: Use care when touching the exterior of an operating motor. Components may be hot enough to burn or cause injury.**
- If bearings require lubrication, very little is needed. A general rule is one-half pump from a grease gun for 1/2" to 1-7/16" shaft diameters and one full pump for 1-11/16" and large diameter shafts for every 1500 to 3000 hours of operation. A lithium-based grease should be used. Bearings should be rotated as they are lubricated to evenly distribute the grease, either by hand or via extended grease lines. Do not attempt to grease bearings from inside the enclosure while the motor is energized. **Caution: Bearings are sealed, over-greasing can cause damage to the bearings. Do not grease until grease comes out of seals. Only add the appropriate amount of grease.**

### 2 Weeks After Start-up

- All fasteners should be checked for tightness each time maintenance checks are performed before restarting unit.
- For belt drive units, belt tension should be checked after the first 2 weeks of fan operation. **See "Pulley Alignment/Proper Belt Tension" on page 55.**

### Every 3 Months

- Filters need to be cleaned and/or replaced quarterly, and more often in severe conditions. Washable filters can be washed in warm soapy water. When re-installing filters, be sure to install with the **airflow in the correct direction** as indicated on the filter.
- All fasteners should be checked for tightness each time maintenance checks are performed before restarting unit.
- Belt tension should be checked quarterly. **See "Pulley Alignment/Proper Belt Tension" on page 55.** Over-tightening will cause excessive bearing wear and noise. Too little tension will cause slippage at start-up and uneven wear.

### Yearly

- Inspect bolts and set screws for tightness. Tighten as necessary.
- Inspect motor for cleanliness. Clean exterior surfaces only. Remove dust and grease from the motor housing to ensure proper motor cooling.
- Remove dirt from the wheel and housing to prevent imbalance and damage.
- Check for gas leak and repair if present.
- Clean flame sensor by rubbing with steel wool to remove any rust build-up. Inspect bearings for wear and deterioration. Replace if necessary.
- Inspect belt wear and replace torn or worn belts.
- For heating season, inspect the burner assembly.
- For cooling season, inspect the cooling module. Refer to cooling manufacturer's recommendations.



## Burner Maintenance

Burner maintenance should be performed annually when entering heating season.

- Verify the unit is off.
- Inspect the pilot assembly, refer to “**Pilot Adjustment**” on page 60. Replace if required.
- Inspect the burner plates.
- Clean the burner plates. Make sure the baffles are secure and attached to the burner.
- Clean burner with wire brush and make sure the burner ports are free of debris. Refer to **Table 10** for drill size(s) to clear ports. Wipe the burner with a clean rag.
- After cleaning the system, turn the system. Visually inspect the flame.

**Table 10 - Burner Orifice Drill Size**

Orifice	Drill Size
Gas Port	1/8”
Air Port	42

## Unit Filters

**Table 11 - Filter Quantity Chart**

Intake	16” x 20”	20” x 25”
Size 1 Standard Sloped	2	-
Size 2 Standard Sloped	-	2
Size 1 Modular Sloped	3	-
Size 2 Modular Sloped	-	3
Size 3 Modular Sloped	6	-
Size 4 Modular Sloped	10	-
Size 5 Modular Sloped	-	8
Size 1 V-Bank	-	3
Size 2 V-Bank	8	-
Size 3 V-Bank	-	8
Size 4 V-Bank	15	-
Size 5 V-Bank	-	12
Size 1 Inline	1	-
Size 2 Inline	-	1
Size 3 Inline	-	2

## **Emergency Shutdown of Unit**

To shutdown the unit in the event of an emergency, do the following:

1. Turn power OFF to the unit from main building disconnect.
2. Turn the external disconnect switch to the OFF position.
3. CLOSE the inlet gas valve located on the heater.

## **Prolonged Shutdown of Unit**

For prolonged shutdown, the following steps should be done:

1. Turn the external disconnect switch to the OFF position.
2. CLOSE the inlet gas valve located on the heater.

To re-start the unit, the following steps should be done:

1. Turn the external disconnect switch to the ON position.
2. OPEN the inlet gas valve located on the heater.



## Start-Up Documentation

**START-UP AND MEASUREMENTS SHOULD BE PERFORMED AFTER THE SYSTEM HAS BEEN AIR BALANCED AND WITH THE HEAT ON (Warranty will be void without completion of this form)**

### Job Information

Job Name		Service Company	
Address		Address	
City		City	
State		State	
Zip		Zip	
Phone Number		Phone Number	
Fax Number		Fax Number	
Contact		Contact	
Purchase Date		Start-up Date	

### Heater Information

Refer to the start-up procedure in this manual to complete this section.

Name Plate and Unit Information		Field Measure Information	
Model Number		Motor Voltage	
Serial Number		Motor Amperage**	
Hardware Rev.		RPM	
Software Rev.		Burner Differential Pressure	Inches WC
Motor Volts		Pilot Flame Signal	VDC
Motor Hertz		Low Fire Flame Signal	VDC
Motor Phase		High Fire Flame Signal	VDC
Motor FLA		High Fire Inlet Gas Pressure	Inches WC
Motor HP		Low Fire Manifold Gas Pressure	Inches WC
Min. Btu/Hr		High Fire Manifold Gas Pressure	Inches WC
Max. Btu/Hr		Thermostat Set Point	
Gas Type		Gas Type	

\*\*If measured amps exceed the FLA rating on the nameplate, fan RPM must be reduced to decrease the measured amps below the nameplate FLA rating.

Temperature Control	Discharge		Activate Based On	Space	
	Space			Intake	
Airflow Direction	Correct			Both	
	Incorrect			Either	

As a result of our dedication to constant improvements and quality, the MANUFACTURER reserves the right to update specifications without notice. Please refer to MANUFACTURER'S website for up to date documentation.

**Scan QR Code for Online Manual**

