



AM-CNDI with PLS Series

Exhaust Island Ventilator with Make-Up Air Accessory

AquaMatic's ETL Listed AM-CNDI ventilator efficiently meets the challenges of any island style cooking application. The perforated linear supply air plenum accessory (PLS) provides up to 90% make-up air.

The AM-CNDI with the perforated linear supply plenum accessory (PLS), is a Type 1, single-island, exhaust canopy used for collection and removal of grease-laden vapors and smoke over all types of restaurant equipment. The ventilator is capable of providing up to 90% make-up air through a perforated stainless steel plenum.

FEATURES

- ETL Listed and ETL Sanitation Listed Product
- Superior Exhaust Flow Rates
- Exceptional Capture and Containment of Cooking Vapors
- Island Configuration
- Front Design Directs Air into Filters
- 100% Type 304 Stainless Steel Construction
- Double Wall 1" Stand-Off on Ends
- Double Wall, Insulated Front
- ETL Listed High Velocity Cartridge Filters
- Grease Drain System
- Pre-punched Hanging Angles
- Factory Pre-wired Lighting
- Face Mounted Controls Optional
- Make-Up Air (PLS Accessory) Features:
 - 90% Air Delivery with Max 200 CFM/ft
 - Low Discharge Velocities
 - Directs Air into Hood's Capture Area
 - Even Distribution of Air Across Length of Ventilator
 - Stainless Steel Construction to Match Ventilator

OPTIONS

- Utility Cabinet
- Fire Suppression System
- Electrical Controls
- Integral Clearance to Combustibles System
- ETL Listed Exhaust Fire Damper
- Supply Fire and/or Volume Damper Assembly (in PLS only)
- Enclosure Panels to Ceiling
- End Panels
- Type 304 Stainless Steel Construction:
 - Exposed Surfaces Only
- Captrate Combo®, Captrate Solo®, stainless steel baffle, high efficiency stainless steel baffle, and aluminum baffle filters
- Lighting:
 - Recessed Incandescent
 - Recessed Fluorescent
- Roof Top Packages
- Exhaust Fans
- Make-Up Air Units:
 - Untempered Units
 - Direct Gas Fired Heated Units
 - Indirect Gas Fired Heated Units
 - Electric Heated Units
 - Heating & Cooling Coils

AquaMatic® offers a total system to insure maximum installation and operating efficiencies. Components consist of the ventilator, fire system and electrical controls contained within an integral utility cabinet, and fan packages including exhaust, untempered and tempered make-up air packages. Also available are air purification and energy management systems. Fire suppression systems include final hookup and inspection. Call your AquaMatic Representative for more details.

PERFORMANCE DATA

Max. Avg. Cooking Surface Temp. (°F)	Min Exhaust CFM/ft	Max Suggested Supply CFM/ft via Front Supply Plenum
450°F - Ovens, Steamers, Kettles, Open-Burner Ranges, Griddles, Fryers	346	314
600°F - Gas Charbroilers, Electric Charbroilers	422	380
700°F - Mesquite Grills, Charcoal Charbroilers, Gas Conveyor Charbroilers, Wood Burning Appliances	475	400

SPECIFICATIONS

Application

The ventilator shall provide flexibility in designing kitchen ventilation equipment and shall be tested and listed for use over 400°F light/medium duty cooking surfaces; 600°F heavy duty cooking surfaces; and up to 700°F extra heavy duty cooking surfaces.

Construction

The ventilator shall be 100% constructed of Type 304 stainless steel with #3 or #4 polish. All seams shall be welded or in conformance with ETL standards. All exposed corners shall be ground and polished to match the ventilator grain. Individual component construction shall be determined by manufacturer and ETL. Construction shall be dependent on the structural application to minimize distortion and other defects. All seams, joints and penetrations of the ventilator where grease-laden vapors and exhaust gases are present, must be liquid-tight, continuous welds in accordance with NFPA 96.

The ventilator shall be constructed to include:

- [A double wall insulated front](#) to eliminate condensation and increase rigidity. The insulation shall have a flexural modulus of 475 EI, meet UL 181 requirements and be in accordance with NFPA 90A and 90B.
- [An integral front baffle](#) to direct grease-laden vapors toward the exhaust filter bank.
- [A dual integral grease drain system](#) on the ventilator with a minimum 1/8" per foot slope, to include an exposed, removable 1/2 pint grease cup to facilitate cleaning.
- [Double wall 1" stand-off on ends](#).
- [A supply air plenum](#), providing make-up air through perforated stainless steel diffuser plates, designed to provide even air distribution.
- [A built-in wiring chase](#) for electrical controls on the front face of the ventilator designed to avoid penetration of the capture area and eliminate the need for an external chaseway.
- [UL incandescent light fixtures and globes](#), allowing up to a 100 watt standard light bulb, installed and pre-wired to a junction box and installed with a maximum of 3'-6" spacing on center.
- [Exhaust duct collar](#) 5" high with 1" flange.
- [A minimum of four connections](#) for hanger rods. Connectors shall have 9/16" holes pre-punched in 1 1/2" x 1 1/2" angle iron at the factory to allow for hanger rod connection by others.
- [ETL Listed high velocity cartridge filters](#), with size and quantity determined by the ventilator's dimensional parameters, but extending the full length of the ventilator with filler panels not to exceed 6". The filter shall be designed to remove in excess of 95% of the cooking by-products generated from the cooking process.

Certifications

The ventilator shall be ETL Listed as "Exhaust Hoods Without Exhaust Damper", ETL Listed to Canadian Safety Standards, ETL Sanitation Listed and built in accordance with NFPA 96.

Documentation

Manufacturer shall furnish complete computer generated submittal drawings including ventilator section view(s), plan view(s), duct sizing, and CFM and static pressure requirements. Static pressure, air velocity and air volume requirements indicated on drawings shall be precise and accurate and ventilator shall preform to said specifications. Drawings shall be available to the engineer, architect and owner for their use in construction, operation and maintenance.

SECTIONAL VIEWS

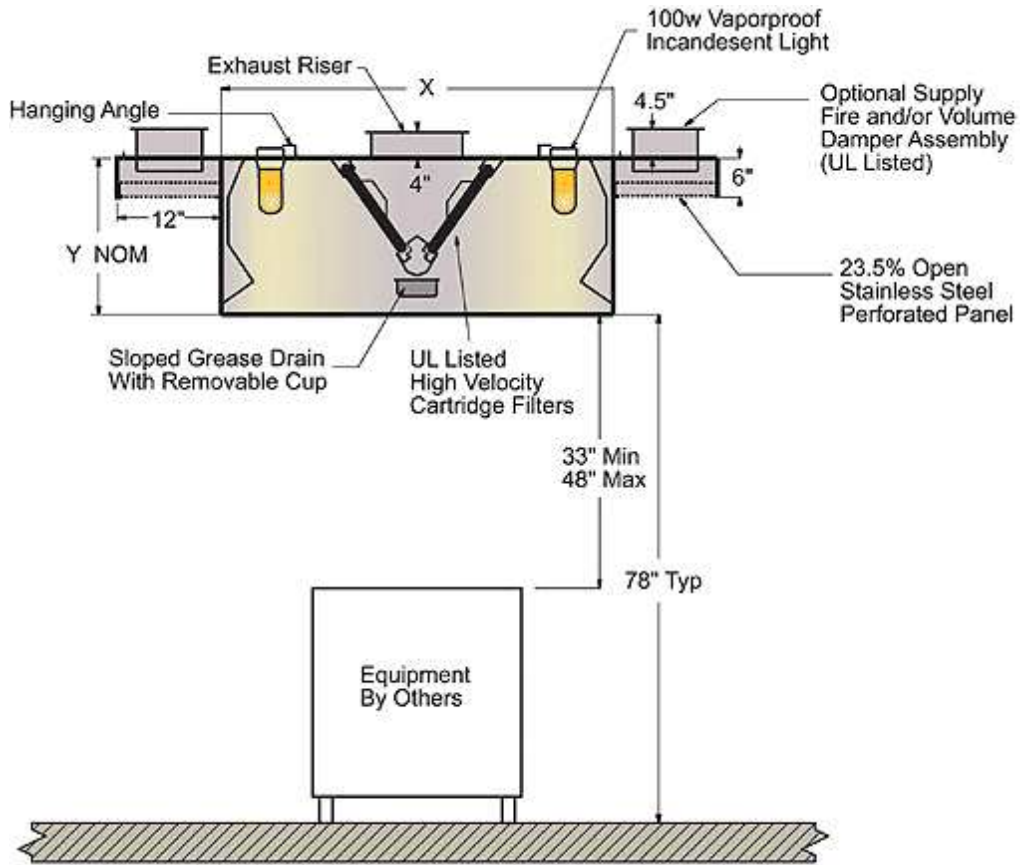

CERTIFICATIONS

The AM-CNDI Model has been certified by ITS. This certification mark indicates that the product has been tested to and has met the minimum requirements of a widely recognized (consensus) U.S. and Canadian products safety standard, that the manufacturing site has been audited, and that the applicant has agreed to a program of periodic factory follow-up inspections to verify continued performance.

Models AM-CNDI are ETL Listed under file number 3054804-001 and complies with UL710, ULC710 and ULC-S646 Standards.

