

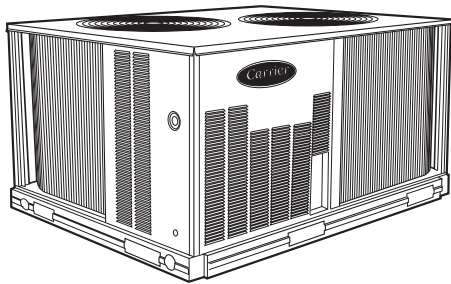

Product Data

38ARZ007-012
38ARS012
38ARD012-024
38AKS014-024
with **40RM007-028** and
28CB,LA008,012
Commercial Air-Cooled
Split Systems

6 to 20 Nominal Tons



38ARZ007-012
38ARS012
38ARD012

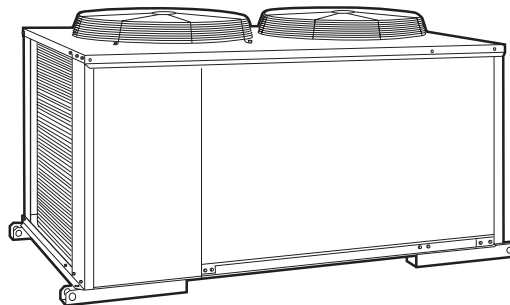

38AKS014-024
38ARD014-024

ASHRAE
90.1
COMPLIANT

Features/Benefits

These dependable split systems match Carrier's indoor-air handlers and direct-expansion coils with outdoor condensing units for a wide selection of commercial cooling solutions.

Constructed for long life

The 38ARZ (single circuit, scroll compressor), 38ARS (single circuit, semi-hermetic compressor), 38ARD (dual circuit, scroll compressor) and 38AKS (single circuit, semi-hermetic compressor) models are designed and built to last. The copper tube-aluminum fin outdoor coil construction provides years of trouble-free operation. Where conditions require, a range of *Enviro-Shield™* coil protection options are available. Cabinets are constructed of prepainted galvanized steel, delivering unparalleled protection from the environment. Inside and outside surfaces are protected to ensure long life, good looks, and reliable operation. Safety controls are used for enhanced system protection and reliability.

Factory-installed options (FIOPs)

Factory-installed options (FIOPs) allow units to be installed in less time, thereby reducing installed cost. FIOPs include:

- low ambient controls
- non-fused disconnect
- 115-v GFI convenience outlet
- *Enviro-Shield* coil protection

Efficient operation

Building owners will appreciate the high unit EERs (Energy Efficiency Ratios) offered by the 38AR and 38AKS units. These units provide

greater efficiency than similar units in the marketplace, which translates into year-round operating savings.

Controls for performance dependability

The 38AR and 38AKS condensing units offer the building owner operating controls and components designed for performance dependability. The highly efficient hermetic and semi-hermetic compressors are engineered for long life and durability. The compressors include overload protection and vibration isolation for quiet operation. The high-pressure switch protects the entire refrigeration system from abnormally high operating pressures. A low-pressure switch protects the system from loss of charge. These units also include anti-short-cycling protection, which helps to protect the units against compressor failure.

The 38ARD012-024 units feature 2 compressors and 2 refrigerant circuits that provide continuous air conditioning and design flexibility.

All units include a crankcase heater to eliminate liquid slugging at start-up. Units with semi-hermetic compressors are also equipped with an oil-level sight glass.

The latest safety standards for 38AR and 38AKS units are assured through UL, Canada approvals.

Innovative Carrier 40RM packaged air handlers are custom matched to 38AR and 38AKS condensing units

The 40RM Series has excellent fan performance, efficient direct-expansion (DX) coils, a unique combination of indoor-air quality features, and is easy to install. Its versatility and state-of-the-art features help to ensure that your

split system provides economical performance now and in the future.

Indoor-air quality (IAQ) features —

The unique combination of IAQ features in the 40RM Series air handlers help to ensure that only clean, fresh, conditioned air is delivered to the occupied space.

Direct-expansion (DX) cooling coils prevent the build-up of humidity in the room, even during part-load conditions. Unit sizes of 10 tons and above feature dual-circuit coils for improved temperature control.

Standard 2-in. disposable filters remove dust and airborne particles from the occupied space for cleaner air.

The pitched, non-corroding drain pan can be adjusted for a right-hand or left-hand connection to suit many applications and provide positive drainage and prevent standing condensate.

The 40RM accessory economizer can provide ventilation air to improve indoor-air quality by using demand control ventilation. When used in conjunction with Carrier Comfort System or PremierLink™ controls and CO₂ sensors, the economizer admits fresh outdoor air to replace stale, recirculated indoor air.

Economy — The 40RM Series packaged air handlers have low initial costs, and provide reduced installation expense and energy-efficient performance.

Quick installation is ensured by the multipoise design. Units can be installed in either the horizontal or vertical configuration without modifications. Fan motors and contactors are prewired and thermostatic expansion valves (TXVs) are factory-installed on all 40RM models.

High efficiency, precision-balanced fans minimize air turbulence, surging, and unbalanced operation, cutting operation expenses.

The economizer accessory precisely controls the blend of outdoor air and room air to achieve comfort levels. When the outside air enthalpy is suitable, outside air dampers can fully open to provide “free” cooling without energizing mechanical cooling.

Rugged dependability — The 40RM series units are made to last. The die-formed galvanized steel panels ensure structural integrity under all operating conditions. Galvanized steel fan housings are securely mounted to a die-formed galvanized steel fan deck.

Rugged pillow-block bearings (40RM014-034) are securely fastened to the solid steel fan shaft with split collets and clamp locking devices. Smaller unit sizes have spider-type bearings.

Coil flexibility — Model 40RM direct-expansion coils have galvanized steel casings; inlet and outlet connections are on the same end. The coils are designed for use with Refrigerant 22 and have 3/8-in. diameter copper tubes mechanically bonded to aluminum sine-wave fins. The coils include matched, factory-installed thermostatic expansion valves (TXVs) with matching distributor nozzles.

Easier installation and service — The multipoise design and component layout help you to get the unit installed and running quickly. Units can be converted from horizontal to vertical operation by simply repositioning the unit. Drain pan connections are duplicated on both sides of the unit. The filters, motor, drive, TXVs, and coil connections are all easily accessed by removing a single side panel.

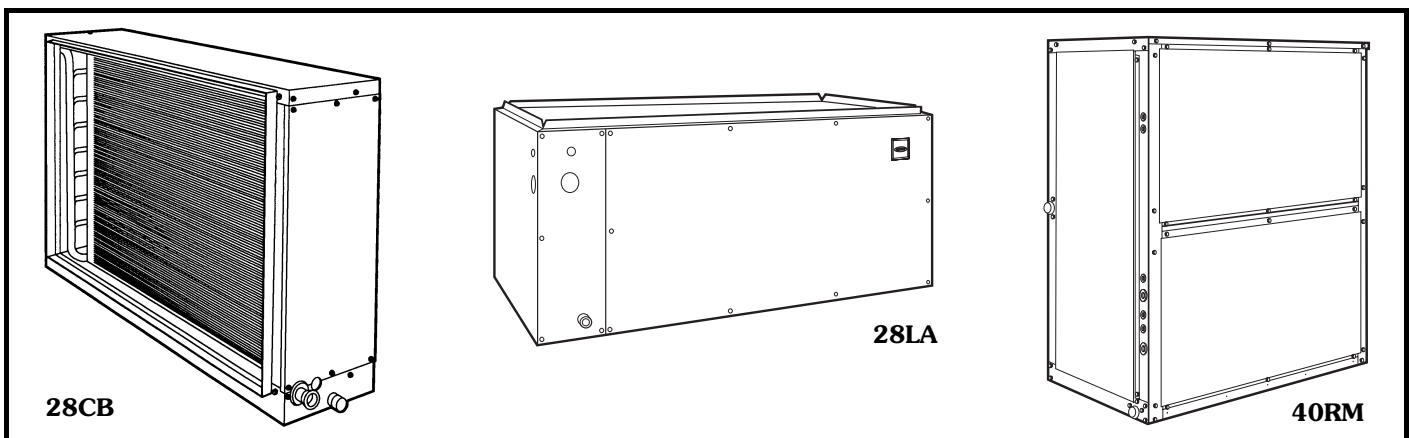

Features/Benefits (cont)



28CB and 28LA direct-expansion evaporator coils matched with 38AR and 38AKS units provide efficient cooling for furnace systems

If your light commercial application calls for direct-expansion evaporator coils in the popular 7½ to 10 ton nominal capacity range, consider Carrier's performance-proven 28CB and 28LA coils. Matched for use with Carrier's 38ARZ condensing units, these versatile coils can be used in

either new construction or renovation projects.

Whether the application is with a duct furnace, or an upflow or horizontal furnace, 28CB and 28LA coils offer cost-saving heat transfer performance. Coil enclosures are fully insulated to maximize cooling power and optimize operating economy.

The 28LA upflow coil offers a variety of piping possibilities...through the front access panel or at either end of the unit, whichever best suits the conditions at the jobsite. The coil includes

a factory-matched and installed thermostatic expansion valve for R-22.

The 28CB horizontal coil matches horizontal and duct furnaces, or can be applied within the duct.

System ratings using the 28CB and 28LA coils are ARI certified, and have been tabulated and selected for combinations that represent reliable, balanced cooling systems. The coils are easy to install; just gasket furnace-to-coil contacting surfaces and you are set to connect field piping in a matter of minutes.

Table of contents

	Page
Features/Benefits	1-3
ARI Capacity Ratings	4
Options and Accessories	5-9
Selection Procedure	10
Controls	11
Typical Control Wiring	12
Typical Wiring Schematic	13,14
38AR007-012	
Model Number Nomenclature	15
Physical Data	16
Dimensions	17,18
Performance Data	19-32
Electrical Data	33
Application Data	34
Typical Piping and Wiring	35
Guide Specifications	36-41
38ARD,AKS014-024	
Model Number Nomenclature	42
Physical Data	43,44
Dimensions	45-47
Performance Data	48-67
Electrical Data	68
Application Data	69-71
Typical Piping and Wiring	72,73
Guide Specifications	74-79
40RM007-028	
Model Number Nomenclature	80
Physical Data	81
Dimensions	82-84
Performance Data	85-90
Electrical Data	91-96
Application Data	97-100
Guide Specifications	101,102
28CB,LA008,012	
Model Number Nomenclature	103
Physical Data	103
Dimensions	104
Guide Specifications	105

ARI* capacity ratings



CONDENSING UNIT	AIR HANDLER/ INDOOR COIL	SYSTEM†			CONDENSING UNIT ONLY**		
		Net Cap. (Btuh)	EER	IPLV	Net Cap. (Btuh)	EER	IPLV
38ARZ007	28LA008	66,000	10.3	N/A	72,000	12.4	N/A
	40RM007††	69,000	11.0	N/A			
	40RM007H††	72,000	11.2	N/A			
	40RM008	71,000	10.8	N/A			
	40RM008H††	74,000	11.0	N/A			
38ARZ008	28CB012	88,000	10.3	N/A	100,000	12.7	N/A
	28LA012	88,000	10.3	N/A			
	40RM007	87,000	10.6	N/A			
	40RM007H††	91,000	11.3	N/A			
	40RM008	90,000	10.6	N/A			
	40RM008H††	94,000	11.2	N/A			
	40RM012	93,000	10.4	N/A			
40RM012H	98,000	10.8	N/A				
38ARZ012	40RM012	118,000	10.3	N/A	133,000	12.4	N/A
	40RM012H	125,000	10.4	N/A			
	40RM014	123,000	10.4	N/A			
	40RM014H	130,000	10.4	N/A			
38ARS012	40RM012	114,000	10.3	13.1	124,000	12.0	16.5
	40RM012H	119,000	10.3	13.6			
	40RM014	118,000	10.4	14.1			
	40RM014H	125,000	10.3	14.5			
38ARD012	40RM012	113,000	10.3	11.7	123,000	12.3	16.0
	40RM012H	118,000	10.5	12.4			
	40RM014	118,000	10.5	12.8			
	40RM014H	124,000	10.9	13.2			
38AKS014	40RM014	138,000	10.4	12.7	150,000	12.1	15.8
	40RM014H	144,000	10.6	13.0			
	40RM016	144,000	10.6	11.6			
	40RM016H	146,000	10.8	13.1			
38ARD014	40RM012	135,000	9.7	9.9	158,000	12.5	15.1
	40RM012H	143,000	10.2	10.3			
	40RM014	145,000	10.5	10.9			
	40RM014H	153,000	11.1	11.5			
	40RM016	152,000	10.8	11.0			
	40RM016H	161,000	11.3	11.5			
38AKS016	40RM016	176,000	9.8	12.3	198,000	11	14.9
	40RM016H	182,000	9.7	12.1			
	40RM024	184,000	9.8	12.2			
	40RM024H	196,000	10.0	12.5			
38ARD016	40RM014	176,000	10.0	10.4	204,000	11.9	13.9
	40RM014H	185,000	10.3	10.8			
	40RM016	187,000	10.2	10.5			
	40RM016H	198,000	10.6	10.9			
	40RM024	194,000	10.1	10.2			
	40RM024H	204,000	10.4	10.4			
38AKS024	40RM028H	244,000	9.5	11.8	248,000	10.5	13.9
38ARD024	40RM024H	243,000	9.6	9.8	259,000	11.2	13.1
	40RM028	242,000	9.6	9.9			
	40RM028H	252,000	9.7	9.9			

LEGEND

- EER — Energy Efficiency Ratio
- IPLV — Integrated Part Load Value
- N/A — Not Applicable
- SST — Saturated Suction Temperature

*Air Conditioning and Refrigeration Institute.

†Ratings in accordance with ARI Standard 210/240 or 360.

**Condensing unit only ratings are at 45 F SST and 95 F entering-air temperature.

††ENERGY STAR® compliant combinations of condensing unit with air handler/ indoor coil indicated.



SOUND LEVELS, dB

UNIT 38	SOUND RATING (60 Hz) dB (A)	OCTAVE BANDS								
		63	125	250	500	1000	2000	4000	8000	
ARZ	007	80.0	71.5	76.8	75.3	74.0	73.9	74.1	73.5	64.0
	008	84.0	84.1	84.5	80.4	78.6	77.2	76.9	78.8	72.5
	012	85.0	88.7	85.4	81.7	80.9	82.1	76.2	73.6	67.1
ARS	012	83.0	78.0	82.6	84.9	78.6	79.5	72.1	69.9	65.8
AKS	014	86.2	—	93.0	86.0	83.0	80.0	78.0	73.0	71.0
	016	86.2	—	93.0	86.0	83.0	80.0	78.0	73.0	71.0
	024	90.0	83.5	81.5	88.5	86.5	85.5	82.5	76.5	61.5
ARD	012	85.0	87.3	84.1	85.9	79.2	77.6	75.3	75.0	68.2
	014	86.9	—	90.9	86.1	83.1	84.0	73.5	71.7	66.7
	016	87.5	—	90.9	86.1	83.4	84.5	76.6	73.2	63.5
	024	88.0	—	90.9	86.1	83.8	84.5	79.2	74.3	65.5

Options and accessories



38AR, 38AKS factory-installed options

Enviro-Shield™ condenser options offer pre-coated coils that provide protection in mild coastal environments. Several options are available to match coil protection to site conditions for optimum durability. See the table below. Consult your Carrier representative for further information.

E-coated aluminum-fin coils have a flexible and durable epoxy coating uniformly applied to all coil surfaces. Unlike brittle phenolic dip and bake coatings, E-coating provides superior protection with unmatched flexibility, edge coverage, metal adhesion, thermal performance, and most importantly, corrosion resistance.

E-coated coils provide this protection since all coil surfaces are completely encapsulated from environmental contamination. This coating is especially suitable in industrial environments.

E-coated copper-fin coils have the same flexible and durable epoxy coating as E-coated aluminum-fin coils. However, this option combines the natural salt and environmental resistance of all-copper construction with high levels of corrosion protection. This coating is recommended for harsh combinations of coastal and industrial environments.

Pre-coated coils provide protection in mild coastal environments.

Copper fin/copper tube coils eliminate the bi-metallic bond found on standard coils.

-20 F low-ambient temperature kit option (Motormaster® 38ARZ,ARS007-012, 38ARD012-024) controls outdoor-fan motor operation to maintain the correct head pressure at low outdoor ambient temperatures.

115-v convenience outlet (38ARZ, 38ARS012 and 38ARD012-024) is used to power electric drills, lights, and refrigerant recovery machines. This means you are no longer required to run a separate 115-v power supply.

Non-fused disconnect switch (38ARZ, 38ARS012 and 38ARD012-024) is used to remove power locally at the condensing unit. This switch also includes a power lockout capability to protect the service person. This lockout switch saves the service person time and effort because there is no need to access a distant disconnect switch while servicing the unit.

38AR, 38AKS field-installed accessories

Electric unloader package (38ARS012, 38AKS014-024) includes hardware and solenoid valve to convert a pressure-operated unloader to electric unloading.

-20 F low-ambient temperature kit accessory (Motormaster) controls outdoor-fan motor operation to maintain the correct head pressure at low outdoor ambient temperatures.

Gage panel package provides a suction and a discharge pressure gage for the refrigerant circuit.

Hail guard package (38ARZ007-012, 38ARS012, 38ARD012) protects coils against damage from flying debris and hail.

Condenser coil grille package protects condensing unit coil from impact by large objects and vandalism.

Carrier's line of thermostats provide both programmable and non-programmable capability with the new **Debonair®** line of commercial programmable thermostats. The **Commercial Electronic** thermostats provide 7-day programmable capability for economical applications.

PremierLink™ Controller is a field retrofit split system control compatible with the Carrier Comfort Network (CCN) and other building automation systems (BAS). This control allows users the access and ability to change factory-defined settings, thus expanding the function of the standard unit.

CONDENSER COIL OPTIONS

COPPER-TUBE COILS WITH ENVIRO-SHIELD OPTION	ENVIRONMENT					
	Standard	Mild Coastal	Moderate Coastal	Severe Coastal	Industrial	Combined Industrial Coastal
Al Fins (Standard Coils)	X					
Cu Fins			X			
Al Fins, E-Coated					X	
Cu Fins, E-Coated				X		X
Al Fins, Pre-Coated		X				

LEGEND

Al — Aluminum
Cu — Copper

Options and accessories (cont)

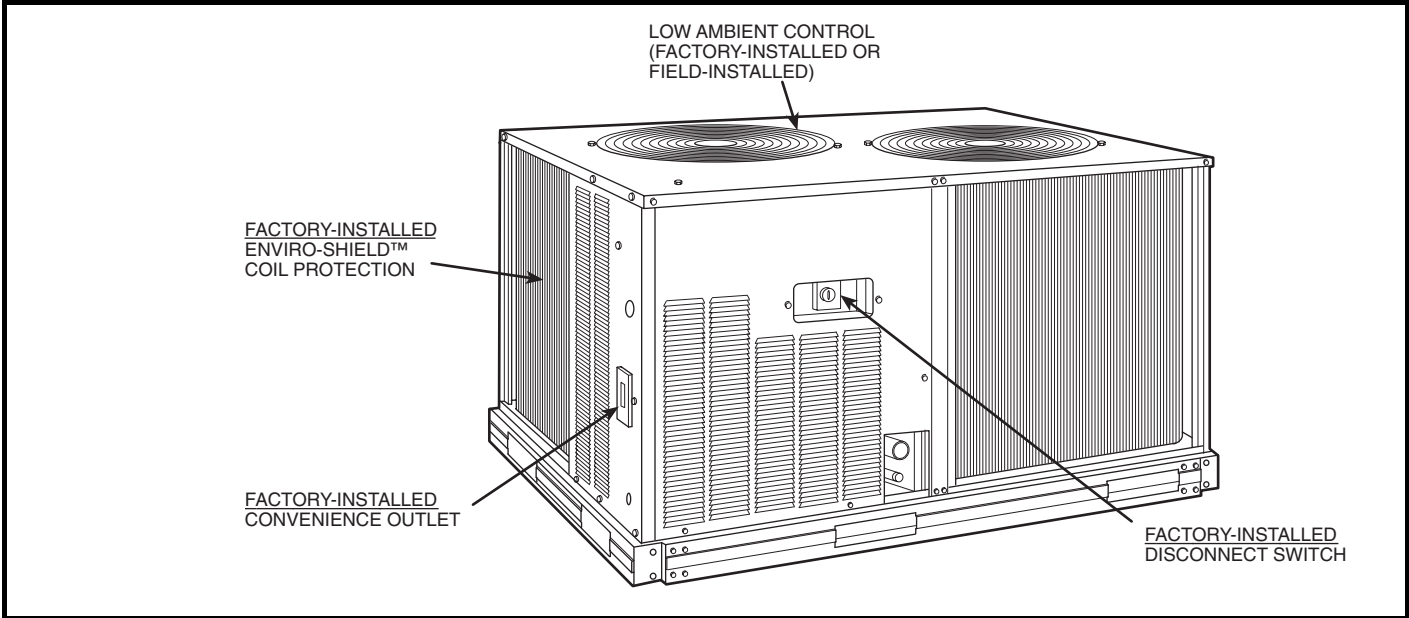



40RM factory-installed options

Alternate fan motors and drives are available to provide the widest possible range of performance.

High-capacity, 4-row evaporator coils are available to provide increased latent and sensible capacities.

Units constructed of prepainted steel are available from the factory for applications that require painted units. Unit color is American Sterling Gray.

40RM field-installed accessories

Two-row hot water coils have $\frac{5}{8}$ -in. diameter copper tubes mechanically bonded to aluminum plate fins. Coils have non-ferrous headers.

One-row steam coil has 1-in. OD copper tube and aluminum fins. The Inner Distributing Tube (IDT) design provides uniform temperatures across the coil face. The IDT steam coils are especially suited to applications where sub-freezing air enters the unit.

Electric resistance heat coils have an open-wire design and are mounted in a rigid frame. Safety cutouts for high temperature conditions are standard.

Economizer (enthalpy controlled) provides ventilation air and provides “free” cooling if the outside ambient temperature and humidity are suitable. The economizer can also be used in conjunction with Carrier Comfort System thermostats, PremierLink™ Controller and CO₂ sensors to help meet indoor air quality requirements.

Discharge plenum directs the air discharge into the occupied space; integral horizontal and vertical louvers enable redirection of airflow. This accessory is available unpainted or painted.

Return-air grille provides a protective barrier over the return-air opening and gives a finished appearance to units installed in the occupied space. This accessory is available unpainted or painted.

Subbase provides a stable, raised platform and room for condensate drain connection for floor-mounted units. This accessory is available unpainted or painted.

Overhead suspension package includes necessary brackets to support units in horizontal ceiling installations.

Condensate drain trap includes an overflow shutoff switch that can be wired to turn off the unit if the trap becomes plugged. The kit also includes a wire harness that can be connected to an alarm if desired. The transparent trap is designed for easy service and maintenance.

CO₂ sensors can be used in conjunction with the economizer accessory to help meet indoor air quality requirements. The sensor signals the economizer to open when the CO₂ level in the space exceeds the set point. A Carrier Comfort System programmable thermostat can also be used to override the sensor if the outside-air temperature is too high or too low.

UV-C germicidal lamps kill mold and fungus that may grow on evaporator coil and condensate pan surfaces. The use of UV-C germicidal lamps eliminates the foul odors that result from mold and fungus growth. These lamps also provide a self-cleaning function for the evaporator coil and drain pan.

Options and accessories (cont)



CARRIER CONTROLS

DEBONAIR® COMMERCIAL PROGRAMMABLE THERMOSTAT

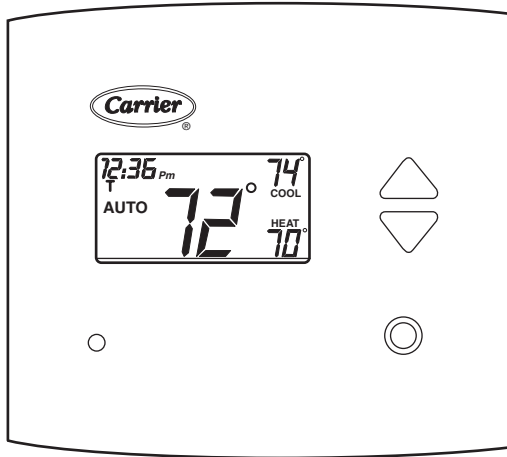

COMMERCIAL ELECTRONIC THERMOSTAT

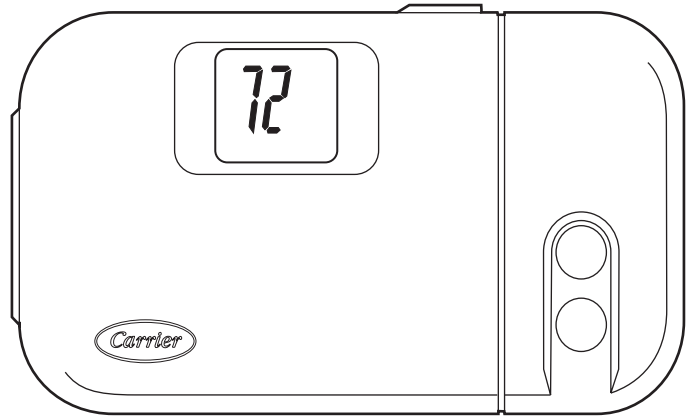

PREMIERLINK™ COMMUNICATING CONTROLS

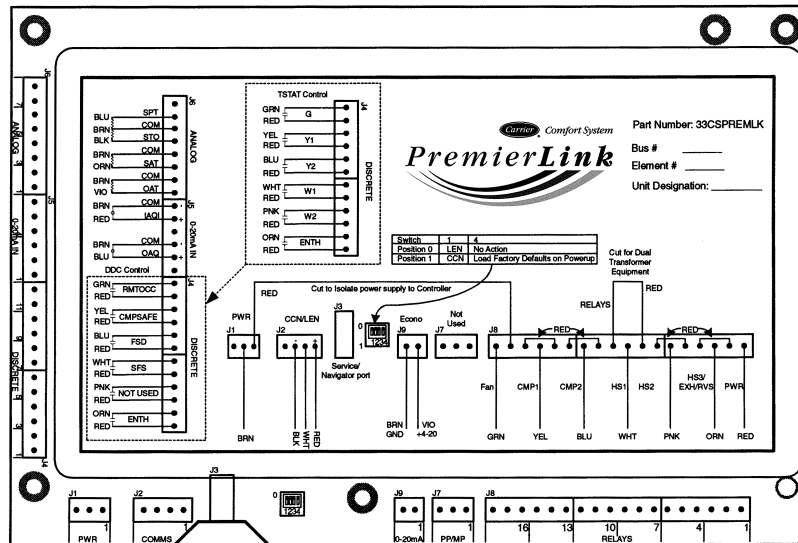

40RM WITH DISCHARGE PLENUM, RETURN GRILLE, AND SUBBASE

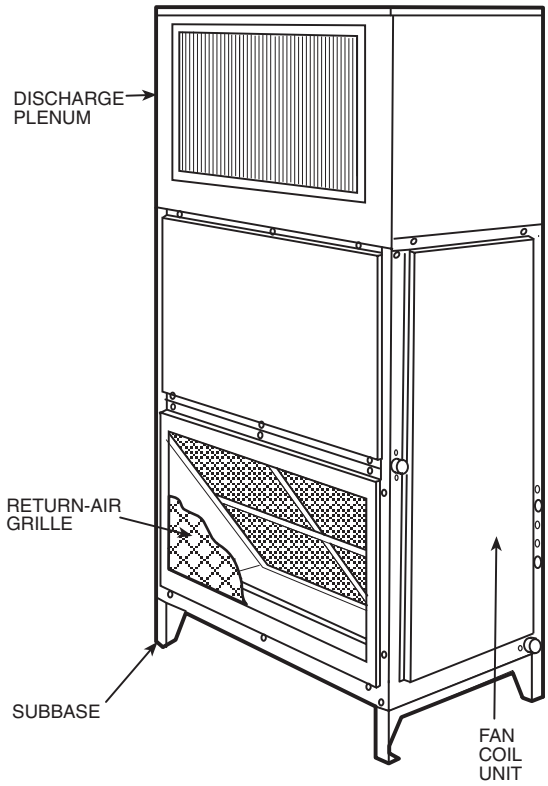

40RM WITH HOT WATER OR STEAM COIL



40RM WITH ECONOMIZER AND UV-C GERMICIDAL LAMPS

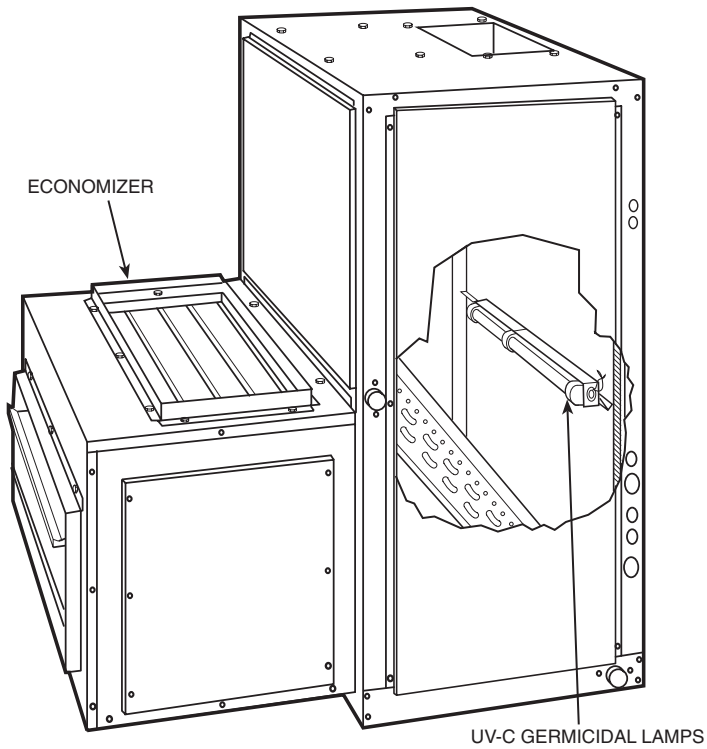

40RM WITH CONDENSATE TRAP

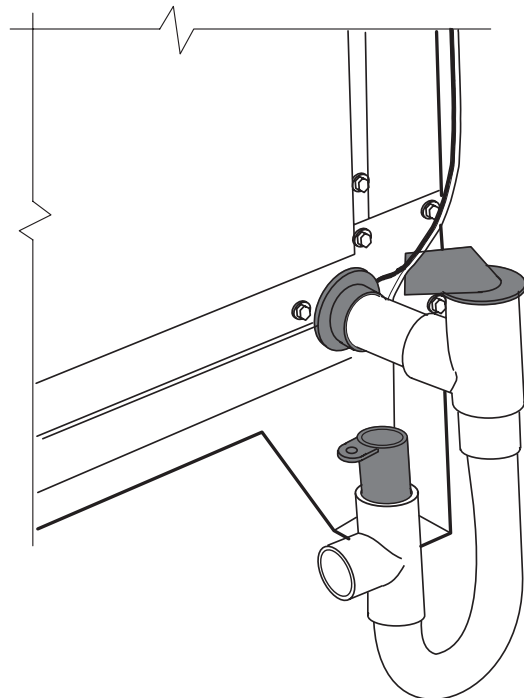

Selection procedure



Combination ratings for 38ARZ, 38ARS, 38AKS and 38ARD units matched with 40RM Series air handlers and 28 Series coils are in this book. If a unit is used with a 39L or 39NX air handler, use the Carrier Electronic Catalog AHU (Air-Handling Unit) selection program to obtain combined ratings.

I Determine cooling load, evaporator-air temperature, and quantity.

Given:

Total Cooling Capacity	
Required (TC)	127,000 Btuh
Sensible Heat Capacity	
Required (SHC)	95,000 Btuh
Compressor Type	Scroll
Temperature Air Entering	
Condenser (Edb)	95 F
Temperature Air Entering	
Evaporator (db/wb)	80 F db, 67 F wb
Evaporator Air Quantity	4,000 cfm
External Static Pressure	0.4 in. wg
Length of Interconnecting	
Refrigerant Piping	25 ft (Linear)
Power Supply (V-Ph-Hz)	208/230-3-60

II Select condensing unit air-handler combination.

For this example, select a 38ARZ012 matched with a 40RM012 with high-capacity 4-row coil. This 38ARZ012/40RM012 condensing unit air-handler combination provides 130,000 Btuh of total cooling capacity and 98,200 Btuh of sensible capacity at the given conditions. If other temperatures or air-flow values are required, interpolate the values from the combination ratings.

III Determine sizes of liquid and suction lines.

Enter Refrigerant Piping Sizes table. The sizes shown are based on an equivalent length of pipe. This equivalent length is equal to the linear length of pipe indicated at the top of each sizing column, plus a 50% allowance for fitting losses. (For a more accurate determination of actual equivalent length in place of using the estimated 50% value, refer to Carrier System Design Manual.) For this example, note in the linear length column that the proper pipe size is 3/8 in. for the liquid line and 1 3/8 in. for the suction line.

IV Determine fan rpm and bhp (brake horsepower).

At the Air Handler Fan Performance table enter at 40RM012 with high capacity coil at 4000 cfm and move to the External Static Pressure (ESP) column. Note that the conditions require 803 rpm at 1.77 bhp.

V Determine motor and drive.

Enter the Fan Motor Data tables and find the standard motor for 40RM012 unit rated at 2.4 Hp. Since the bhp required is 1.77, a standard motor satisfies the requirement and should be used.

Next, find the type of drive that satisfies the 803 rpm requirement in the Drive Data tables. For the 40RM012 unit, the Standard Drive table on shows an rpm range of 666-863. Since the rpm required is 803, the standard drive satisfies the requirement and should be used. Select the standard motor and standard drive combination (option code GC or ED).

Operating sequences

38ARZ007-012, 38ARS012 — At start-up, the thermostat calls for cooling. With all safety devices satisfied, the compressor contactor and fan contactor energize, causing the compressor and outdoor-fan motor to operate. Thermostat contacts energize, allowing the field-supplied and field-installed indoor-fan contactor to function. A field-supplied and field-installed liquid line valve also opens, allowing the system to function in Cooling mode. As cooling demand is satisfied, the thermostat contacts break, deenergizing the contactor and causing the system to shut off. The liquid line solenoid valve closes, minimizing the potential for refrigerant migration. The compressor does not restart until the thermostat again calls for cooling. The system is protected with a safety circuit so that the system will not start if a fault exists (i.e., high or low pressure fault). To reset the safety circuit, set the thermostat to eliminate the cooling demand, then return it to the original set point. This should be done only once, and if the system shuts down due to the same fault, determine the problem before attempting to restart the system.

38AKS014-024 — When the first stage of cooling thermostat closes, the timer starts. After approximately 3 seconds, the timer activates the compressor and fan motor no. 1 contactors. When the liquid pressure builds to approximately 257 psig, fan motor no. 2 is energized.

When there is demand for additional cooling capacity, the second stage of the cooling thermostat closes, energizing a field-supplied liquid line solenoid (LLS) valve, which opens. This increases the suction pressure, causing the compressor to operate at higher capacity (compressor loads).

When the fan switch is set at AUTO, the indoor-air fan cycles with the compressor. When the switch is set at CONT, the indoor-air fan runs continuously.

At shutdown, the Time Guard II timer prevents the compressor from restarting for approximately 5 minutes.

In addition, an LLS valve wired in parallel with the compressor contactor coil shuts off the liquid line to prevent refrigerant migration back to the compressor during the off cycle.

38ARD012 — When the thermostat calls for stage one cooling at start-up, and all safety devices are satisfied, the compressor contactor 1 (C1) energizes causing compressor no. 1 and outdoor-fan motor no. 1 to start (the indoor-fan contactor should be wired to start at the same time as the compressor). The liquid line solenoid (LLS) valve will open when compressor no. 1 starts, allowing refrigerant to flow in the system.

When the thermostat calls for stage two cooling, compressor contactor no. 2 (C2) energizes causing compressor no. 2 and outdoor-fan motor no. 2 to start. As the cooling demand decreases, stage two on the thermostat opens, causing compressor no. 2 and outdoor-fan motor no. 2 to shut down. As the cooling continues to decrease, stage one of the thermostat opens causing compressor no. 1 and outdoor-fan motor no. 1 to shut down. The LLS valve for each compressor will close when the associated

compressor stops, minimizing the potential for refrigerant migration during the off cycle.

The indoor-fan motor will stop if the thermostat is set to AUTO and will continue to operate if the thermostat is set to CONT. Each compressor is protected with a Cycle-LOC™ device so that the compressor will not operate if there is a high-pressure fault, low pressure fault, or a compressor is off due to internal line break overcurrent/over temperature protection. To reset the Cycle-LOC device, set the thermostat higher to remove the cooling demand, then return it to the original set point. This should be done only once. If the system shuts down with the same fault, the cause for the fault should be determined and corrected before the Cycle-LOC device is reset again.

38ARD014-024 — At start-up, when the thermostat calls for first stage cooling and all safety devices are satisfied, the compressor contactor (C1) energizes causing compressor no. 1 and fan motor no. 1 to start. Fan motor no. 2 will start when the fan cycling pressure switch (FCPS) closes as discharge pressure builds (refer to physical data table for FCPS specifications). With the indoor-fan contactor wired to TB2-4 and TB2-9 contacts on the terminal block, the indoor-fan will also start with the compressor. The liquid line solenoid (LLS) valve will open when compressor no. 1 starts, allowing refrigerant to flow in the system.

When the thermostat calls for stage two cooling, compressor contactor no. 2 (C2) energizes causing compressor no. 2 to start. As the cooling demand decreases, stage two on the thermostat opens, causing compressor no. 2 to shut down. As the cooling continues to decrease, stage one of the thermostat opens causing compressor no. 1 and the outdoor-fan motor to shut down. The LLS valve for each compressor will close when the associated compressor stops, minimizing the potential for refrigerant migration during the off cycle.

The indoor-fan motor will stop if the thermostat is set to AUTO and will continue to operate if the thermostat is set on CONT. Each compressor is controlled by the thermostat so they will not start until there is a demand from the thermostat. Each compressor is protected with a Cycle-LOC device so that the compressor will not operate if there is a high-pressure fault, low-pressure fault, or a compressor is off due to internal line break overcurrent/over temperature protection. To reset the Cycle-LOC device, set the thermostat higher to remove the cooling demand, then return it to the original set point. This should be done only once. If the system shuts down with the same fault, the cause for the fault should be determined and corrected before the Cycle-LOC device is reset again.

Typical control wiring

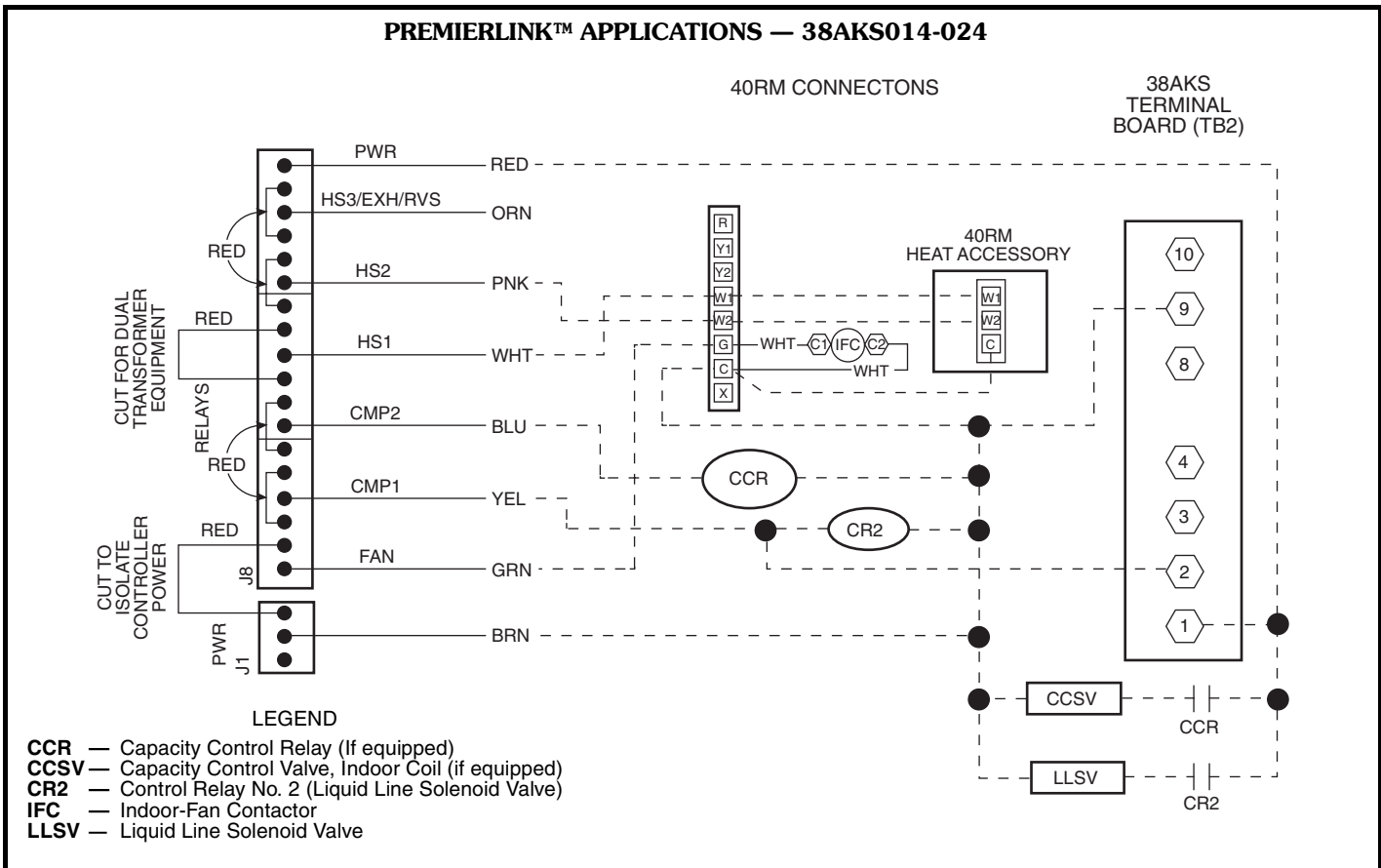
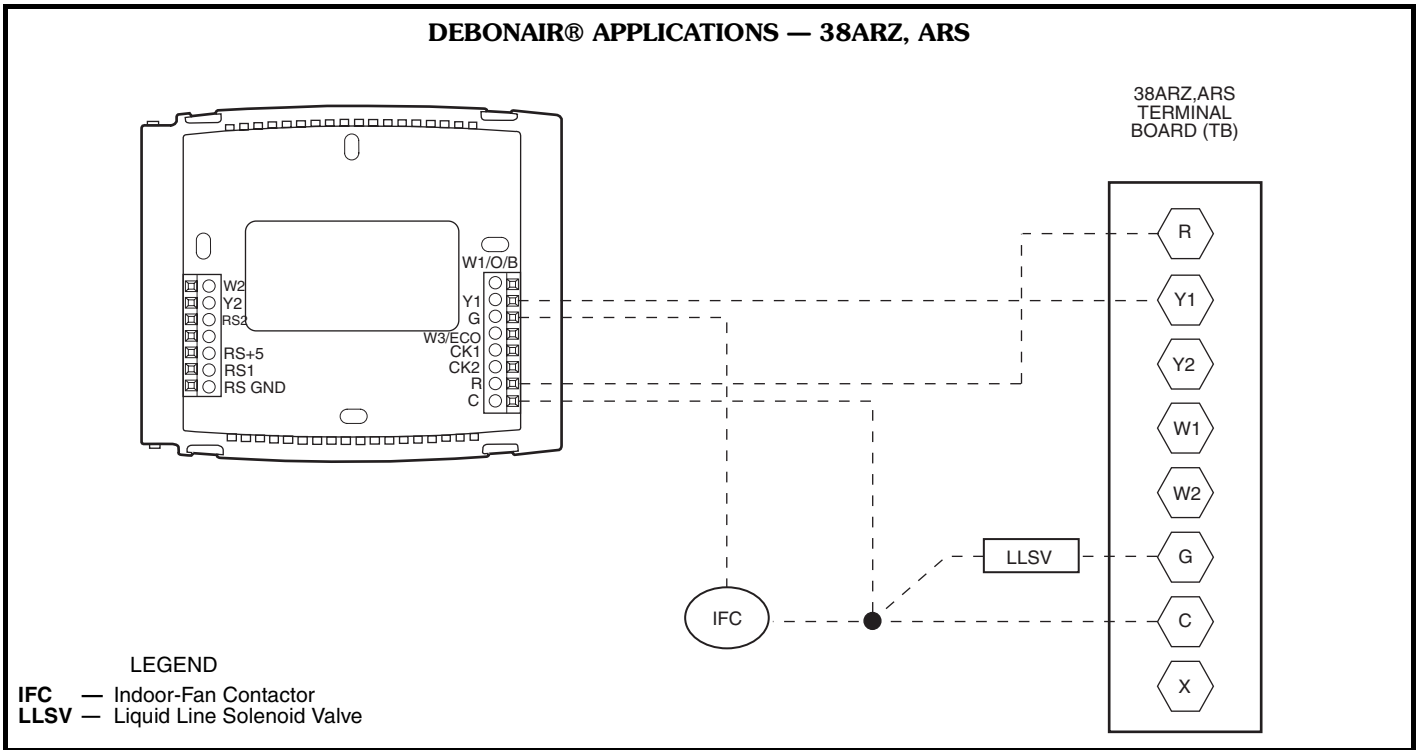

Typical wiring schematic



38ARZ008, 208/230-3-60, 400-3-50, 460-3-60

- NOTES:**
- IF ANY OF THE ORIGINAL WIRE FURNISHED MUST BE REPLACED, IT MUST BE REPLACED WITH TYPE 90°C WIRE OR ITS EQUIVALENT.
 - THERMOSTAT:**
 HH0TAT170, 172, 174 & P272-2783
SUBBASE:
 HH93AZ176, 178 & P272-1882, 1883
 OR: HH93AZ177 & 179
 - SEALED VA FOR IFC & LLSV IS NOT TO EXCEED 22.
 - USE COPPER CONDUCTORS ONLY.
 - TRAN IS WIRED FOR 230V UNIT. IF UNIT IS TO BE RUN WITH 200V POWER SUPPLY DISCONNECT BLK WIRE FROM 230V TAP AND CONNECT TO 200V TAP.
 - IF TRAN IS WIRED FOR 460-3-60V & UNIT IS TO BE RUN WITH 400-3-50V POWER SUPPLY DISCONNECT BLK WIRE FROM 460V TAP AND CONNECT TO 400V TAP.
 - THREE PHASE MOTORS ARE PROTECTED UNDER PRIMARY SINGLE PHASING CONDITIONS.

VOLTAGE RATING	CB MFG. PART NO.	MUST TRIP AMPS
24V	W28X-1024-3.2	3.2

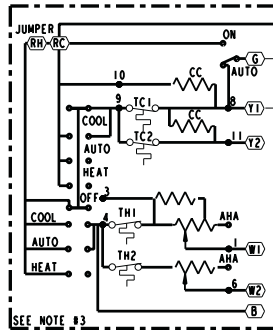
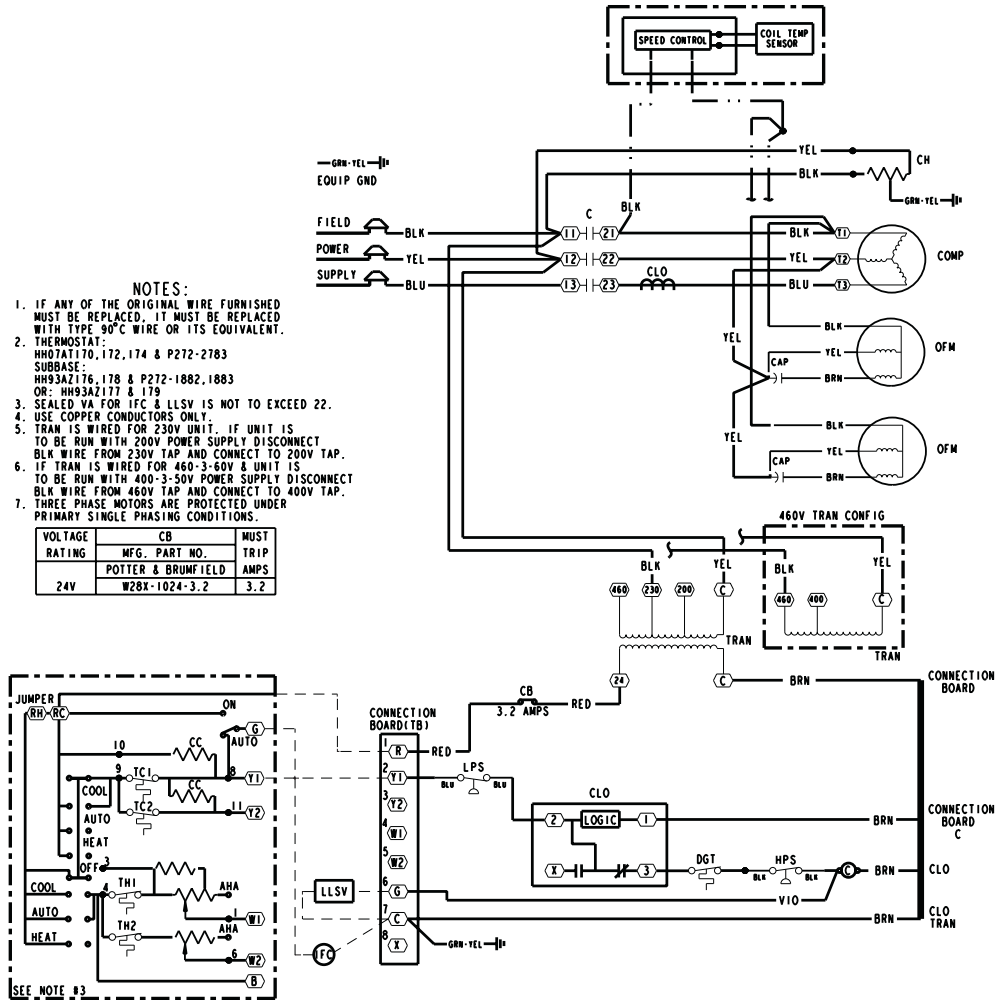

COMPONENT ARRANGEMENT

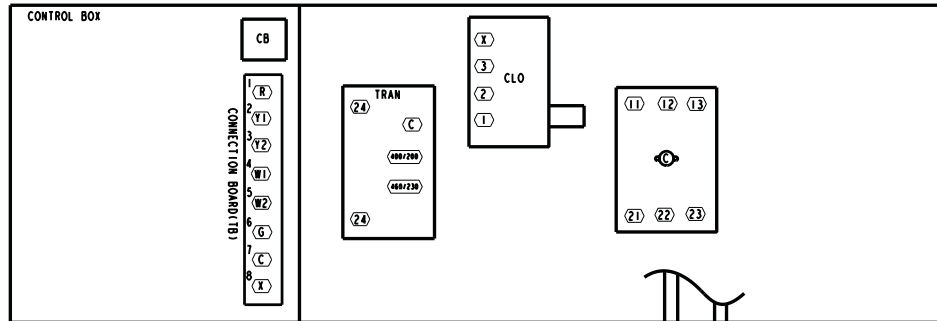

FIELD CONTROL WIRING

LEGEND

- FIELD SPLICE
- MARKED WIRE
- TERMINAL (MARKED)
- TERMINAL (UNMARKED)
- TERMINAL BLOCK
- SPLICE
- FACTORY WIRING
- FIELD CONTROL WIRING
- FIELD POWER WIRING
- ACCESSORY OR OPTIONAL WIRING
- TO INDICATE COMMON POTENTIAL ONLY, NOT TO REPRESENT WIRING
- AHA ADJUSTABLE HEAT ANTICIPATOR
- C CONTACTOR, COMPRESSOR
- CAP CAPACITOR, COMPRESSOR
- CB CIRCUIT BREAKER
- CC COOLING COMPENSATOR
- CH CRANKCASE HEATER
- CLO COMPRESSOR LOCKOUT
- COMP COMPRESSOR MOTOR
- DGT DISCHARGE GAS THERMOSTAT
- EQUIP EQUIPMENT
- GND GROUND
- HPS HIGH PRESSURE SWITCH
- IFC INDOOR FAN CONTACTOR
- LLSV LIQUID LINE SOLENOID VALVE
- LPS LOW PRESSURE SWITCH
- OFM OUTDOOR FAN MOTOR
- OT QUADRUPLE TERMINAL
- TB TERMINAL BLOCK
- TC THERMOSTAT-COOLING
- TH THERMOSTAT-HEATING
- TRAN TRANSFORMER

FIELD WIRING
DISCONNECT PER NEC

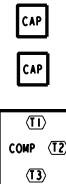

Typical wiring schematic (cont)



38ARS012, 208/230-3-60 AND 460-3-60 UNITS

- NOTES:**
- IF ANY OF THE ORIGINAL WIRE FURNISHED MUST BE REPLACED, IT MUST BE REPLACED WITH TYPE 90°C WIRE OR ITS EQUIVALENT.
 - THERMOSTAT:
HH07A1170, 172, 174 & P272-2783
SUBBASE:
HH93A2176, 178 & P272-1882, 1883
OR: HH93A2177 & 179
 - SEALED VA FOR IFC & LLSV IS NOT TO EXCEED 22.
 - USE COPPER CONDUCTORS ONLY.
 - UNIT IS WIRED FOR 230V UNIT. IF UNIT IS TO BE RUN WITH 200V POWER SUPPLY DISCONNECT, BLK WIRE FROM 230V TAP AND CONNECT TO 200V TAP.
 - IF TRAN IS WIRED FOR 460-3-60V & UNIT IS TO BE RUN WITH 400-3-50V POWER SUPPLY DISCONNECT, BLK WIRE FROM 460V TAP AND CONNECT TO 400V TAP.
 - THREE PHASE MOTORS ARE PROTECTED UNDER PRIMARY SINGLE PHASING CONDITIONS.

VOLTAGE RATING	CB MFG. PART NO.	MUST TRIP AMPS
24V	POTTER & BRUMFIELD W28X-1024-3.2	3.2

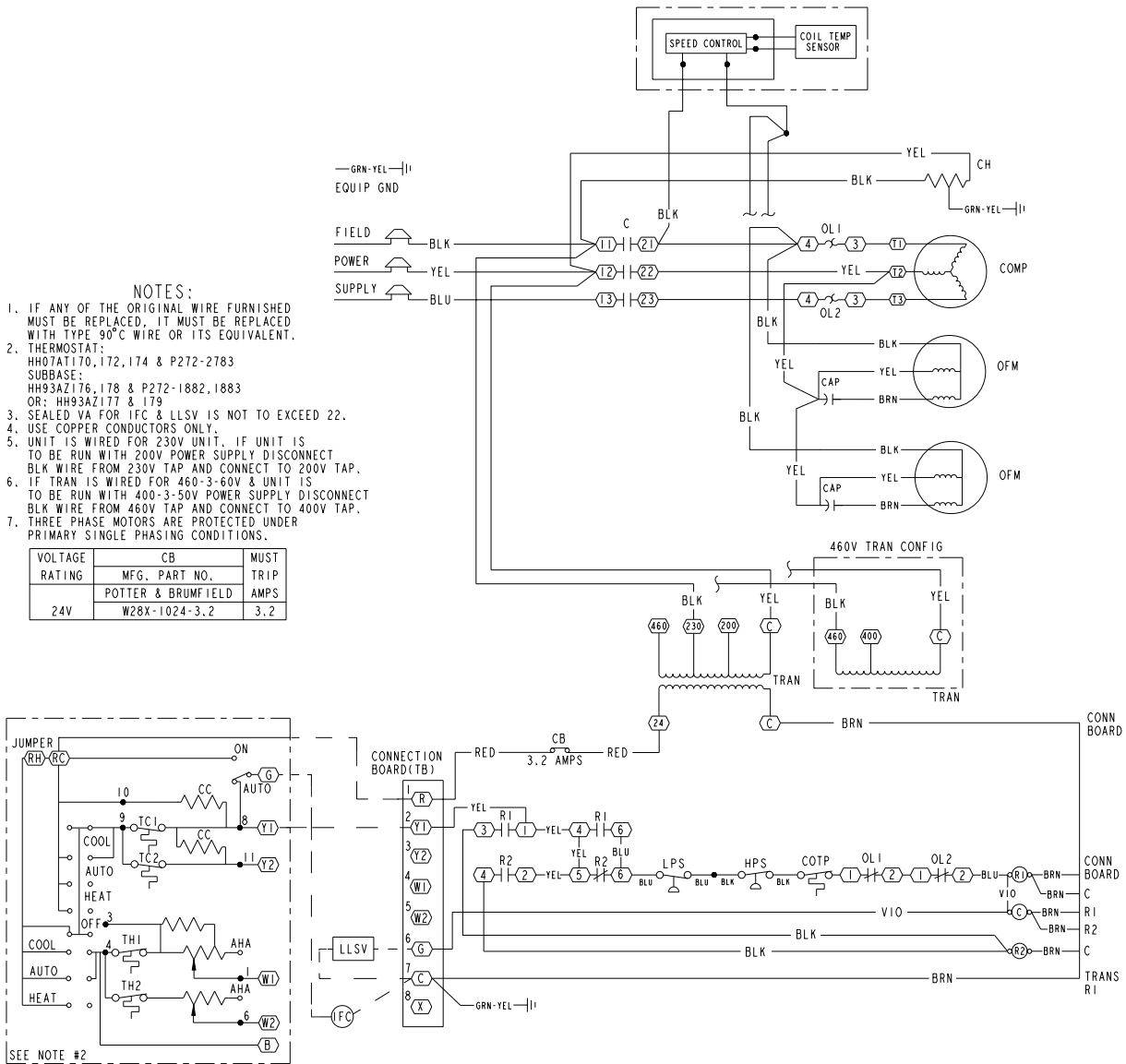

LEGEND

- AHA** — Adjustable Heat Anticipator
- C** — Contactor, Compressor
- CAP** — Capacitor
- CB** — Circuit Breaker
- CC** — Cooling Compensator
- CH** — Crankcase Heater
- COMP** — Compressor Motor
- COTP** — Compressor Over Temperature Protection
- EQUIP** — Equipment
- GND** — Ground
- HPS** — High-Pressure Switch
- IFC** — Indoor-Fan Contactor
- LLSV** — Liquid Line Solenoid Valve
- LPS** — Low-Pressure Switch
- OFM** — Outdoor-Fan Motor
- OL** — Overload Relay
- R** — Relay
- TB** — Terminal Block
- TC** — Thermostat-Cooling
- TH** — Thermostat-Heating
- TRAN** — Transformer

- Field Splice
- Marked Wire
- Terminal (Marked)
- Terminal (Unmarked)
- Terminal Block
- Splice
- Factory Wiring
- Field Control Wiring
- Field Power Wiring
- Accessory or Optional Wiring
- To Indicate Common Potential Only, Not Represent Wiring

Model number nomenclature — 38ARZ007-012, 38ARS012 and 38ARD012

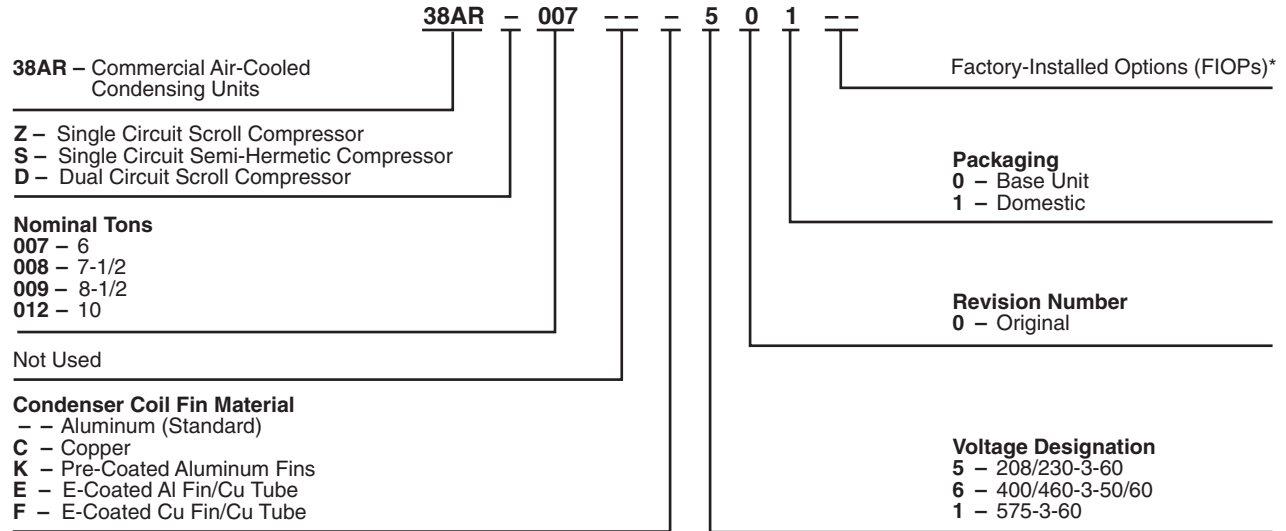

*Refer to 38AR price pages for FIOP codes or contact your local Carrier representative.

Quality Assurance

Certified to ISO 9001:2000

38AR007-012

Physical data



38ARZ007-012, 38ARS012, 38ARD012

38AR007-012

UNIT SIZE 38AR	Z007	Z008	Z012	S012	D012
NOMINAL CAPACITY (tons)	6	7 ¹ / ₂	10	10	10
OPERATING WEIGHT (lb)					
Aluminum Coils (Standard)	300	383	430	575	488
Copper Coils (Optional)	352	484	531	676	589
REFRIGERANT TYPE*	R-22				
Operating Charge, Typical (lb)†	12	20	22	24	11/Circuit
Shipping Charge (lb)	2.0	2.0	2.0	2.0	2.0
COMPRESSOR		Scroll		Reciprocating	Scroll
Qty...Model	1...SR_68	1...SR_94	1...ZR125	1...06DH825	2...SR_60
Oil Charge (oz)	88	90	110	128	72 (ea)
No. Cylinders		N/A		6	N/A
Speed (rpm)		3500		1750	3500
CONDENSER FAN					
Qty...Rpm	2...850	2...1100	2...1100	2...1100	2...1100
Motor HP	¹ / ₈	¹ / ₄	¹ / ₄	¹ / ₄	¹ / ₄
Diameter (in.)	22	22	22	22	22
Nominal Airflow (Cfm Total)	5400	6500	6500	6500	6500
Watts (Total)	340	570	570	570	570
CONDENSER COIL (Qty)		2		2	2
Face Area (sq ft total)		29.2		29.2	29.2
Rows...Fins/in.	1...17	2...17	2...17	2...17	2...17
Storage Capacity (lb)**	17.3	34.2	34.2	34.2	17.1 (ea)
CONTROLS					
Pressurestat Settings (psig)					
High Cutout		428 ± 10		428 ± 10	428 ± 10
Cut-in		320 ± 20		320 ± 20	320 ± 20
Low Cutout		27 ± 3		27 ± 3	27 ± 3
Cut-in		44 ± 5		44 ± 5	44 ± 5
DISCHARGE GAS THERMOSTAT (°F)					
Cutout	—	270 ± 9	—	—	—
Cut-in	—	190 ± 13	—	—	—
PRESSURE RELIEF					
Location	Suction Line				
Temperature (F)	200				
PIPING CONNECTIONS (in. ODM)					
Qty...Suction	1...1 ¹ / ₈	1...1 ¹ / ₈	1...1 ³ / ₈	1...1 ³ / ₈	2...1 ¹ / ₈
Qty...Liquid	1... ³ / ₈	1... ³ / ₈	1... ¹ / ₂	1... ¹ / ₂	2... ³ / ₈

*Unit is factory-supplied with holding charge only.

†Typical operating charge with 25 ft of interconnecting piping.

**Storage capacity of condenser coil with coil 80% full of liquid R-22 at 95 F.

NOTE: Unit 38ARS012 has one step of unloading. Full load is at 100% of capacity, and one step of unloading is 67% capacity. Unit 38ARS012 has the following unloader settings: load is 70 ± 1 psig and unload is 60 ± 2 psig.

38ARZ007-012, 38ARS012

UNIT 38AR	ELECTRICAL CHARACTERISTICS	ALUMINUM COIL										COPPER COILS													
		Std Unit Wt		Corner W		Corner X		Corner Y		Corner Z		Center of Gravity		Std Unit Wt		Corner W		Corner X		Corner Y		Corner Z		Center of Gravity	
		Lb	Kg	Lb	Kg	Lb	Kg	Lb	Kg	Lb	Kg	X mm [in.]	Y mm [in.]	Lb	Kg	Lb	Kg	Lb	Kg	Lb	Kg	Lb	Kg	X mm [in.]	Y mm [in.]
Z007	208/230-3-60, 400/460-3-50/60, 575-3-60	300	136	62	28	103	47	62	28	72	33	831.9 [32.75]	641.4 [25.25]	352	160	95	43	92	42	92	42	72	33	789.7 [31.09]	619.3 [24.38]
Z008	208/230-3-60, 400/460-3-50/60, 575-3-60	383	174	86	39	123	56	85	39	89	40	822.3 [32.38]	635.0 [25.00]	484	220	122	55	137	62	122	55	104	47	806.5 [31.75]	621.8 [24.48]
Z012	208/230-3-60, 400/460-3-50/60, 575-3-60	430	195	84	38	166	75	66	30	114	52	812.8 [32.00]	676.3 [26.63]	531	241	121	55	178	81	103	47	128	58	800.1 [31.50]	656.3 [25.84]
S012	208/230-3-60, 400/460-3-50/60, 575-3-60	575	261	55	25	265	120	88	40	167	76	927.1 [36.50]	647.7 [25.50]	676	307	94	43	276	125	127	58	179	81	900.2 [35.44]	636.3 [25.05]

SERVICE VALVE CONNECTIONS

Unit 38AR	Suction mm [in.]	Liquid mm [in.]
Z007	28.6 [1 ¹ / ₈]	9.5 [3 ⁷ / ₈]
Z008	28.6 [1 ¹ / ₈]	9.5 [3 ⁷ / ₈]
Z012	34.9 [1 ³ / ₈]	12.7 [1 ¹ / ₂]
S012	34.9 [1 ³ / ₈]	12.7 [1 ¹ / ₂]

NOTES:

- Minimum clearance (local codes or jurisdiction may prevail):
 - Bottom to combustible surfaces: 0 inches.
 - Outdoor coil, for proper airflow: 36 inches one side, 12 inches the other. The side getting the greater clearance is optional.
 - Overhead: 60 inches, to assure proper outdoor fan operation.
 - Between units: Control box side, 42 inches per NEC.
 - Between unit and ungrounded surfaces: Control box side, 36 inches per NEC.
 - Between unit and block or concrete walls and other grounded surfaces, control box side, 42 inches per NEC.
- With exception of the clearance for the outdoor coil as stated in Note 1B, a removal fence or barricade requires no clearance.
- Units may be installed on combustible floors made from wood or Class A, B or C roof covering material.

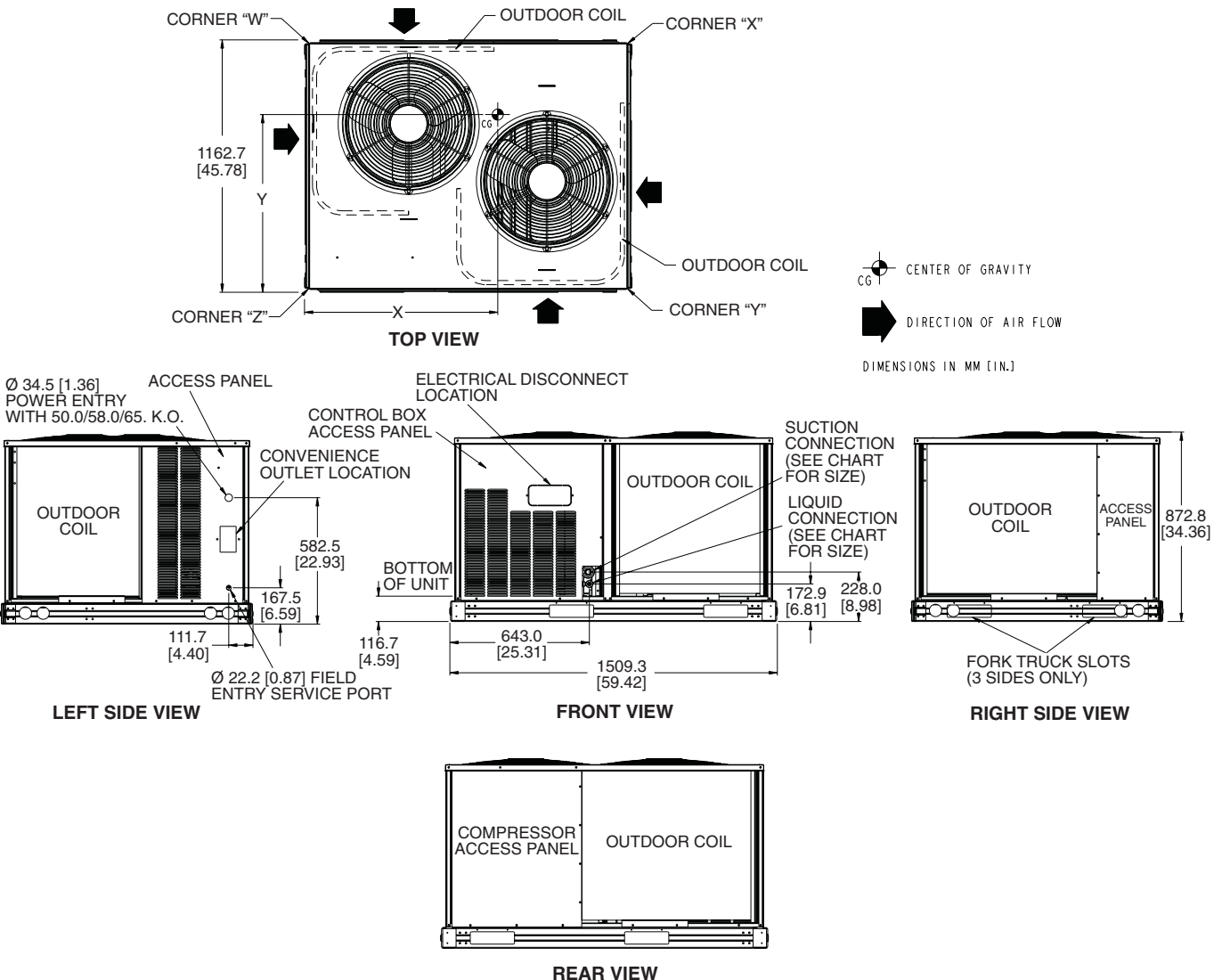

38AR007-012

Dimensions (cont)



38AR007-012

38ARD012

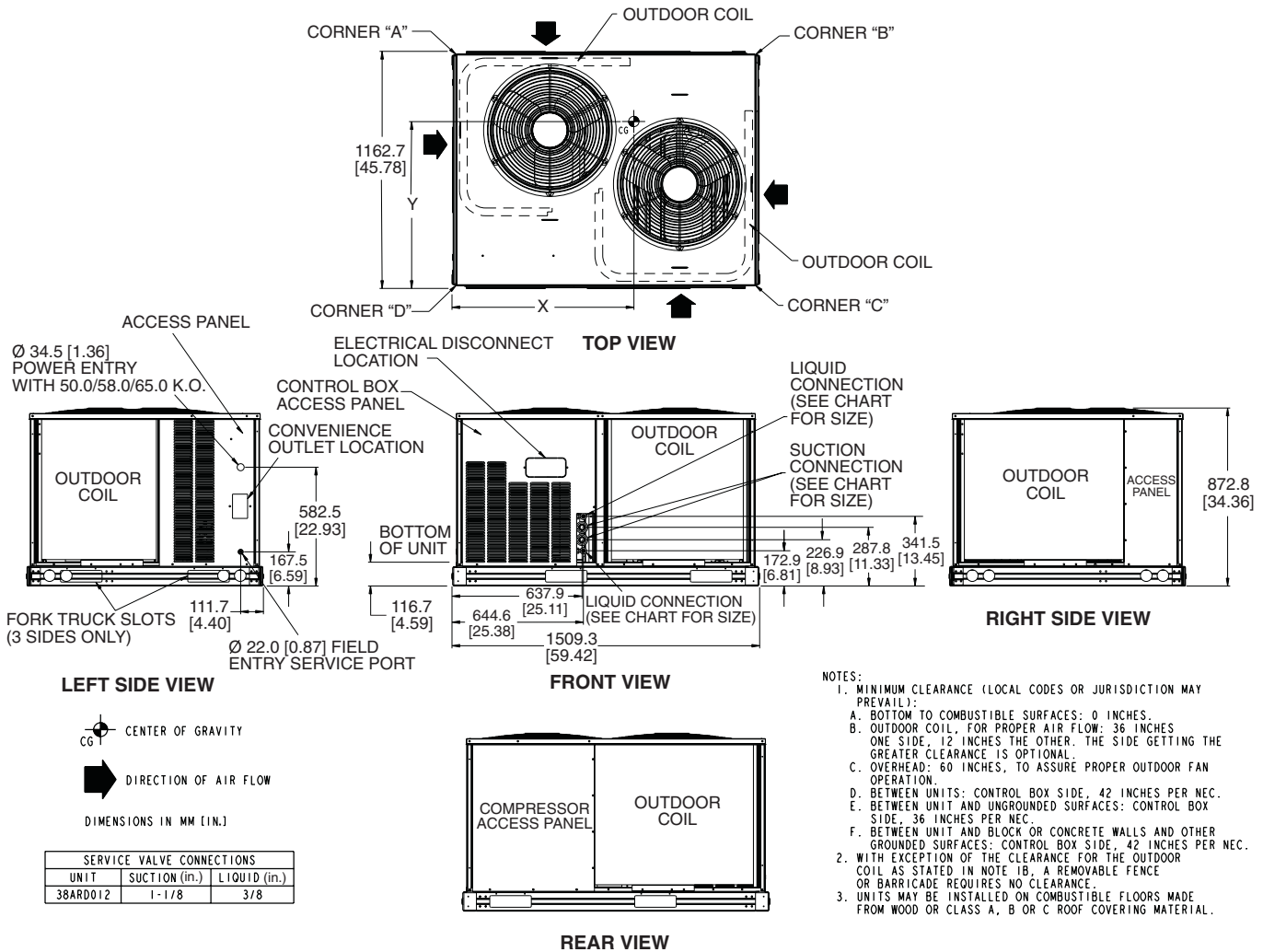

UNIT	ELECTRICAL CHARACTERISTICS	ALUMINUM COIL										COPPER COIL													
		Std. Unit Wt.		Corner A		Corner B		Corner C		Corner D		Center of Gravity		Std. Unit Wt.		Corner A		Corner B		Corner C		Corner D		Center of Gravity	
		lb	kg	lb	kg	lb	kg	lb	kg	lb	kg	X mm [in.]	Y mm [in.]	lb	kg	lb	kg	lb	kg	lb	kg	lb	kg	X mm [in.]	Y mm [in.]
38ARD012	208/230-3-60, 400/460-3-50/60, 575-3-60	488	221	102	46	143	65	139	63	104	47	873.8 [34.4]	591.8 [23.3]	589	267	129	59	166	75	164	74	130	59	845.8 [33.3]	579.1 [22.8]

Performance data



CONDENSING UNIT RATINGS

38ARZ007							
SST (F)		Air Temperature Entering Condenser (F)					
		80	85	95	100	105	115
25	TC	53.6	52.3	49.4	48.0	46.5	43.6
	kW	4.24	4.49	5.02	5.31	5.60	6.24
	SDT	101.0	106.0	115.0	120.0	125.0	135.0
30	TC	59.1	57.6	54.6	53.0	51.5	48.3
	kW	4.33	4.57	5.10	5.39	5.69	6.33
	SDT	102.0	107.0	117.0	122.0	126.0	136.0
35	TC	64.9	63.3	60.1	58.4	56.7	53.4
	kW	4.42	4.67	5.20	5.49	5.79	6.43
	SDT	104.0	109.0	118.0	123.0	128.0	138.0
40	TC	71.0	69.3	65.8	64.1	62.3	58.7
	kW	4.53	4.77	5.31	5.60	5.90	6.55
	SDT	106.0	110.0	120.0	125.0	129.0	139.0
45	TC	77.4	75.6	71.9	70.1	68.2	64.3
	kW	4.65	4.89	5.43	5.72	6.02	6.68
	SDT	107.0	112.0	122.0	126.0	131.0	141.0
50	TC	84.2	82.3	78.4	76.4	74.3	70.2
	kW	4.78	5.03	5.56	5.86	6.16	6.81
	SDT	109.0	114.0	123.0	128.0	133.0	142.0

38ARZ008							
SST (F)		Air Temperature Entering Condenser (F)					
		80	85	95	100	105	115
25	TC	73.9	71.7	67.0	64.6	62.1	57.0
	kW	5.81	6.14	6.84	7.21	7.58	8.36
	SDT	98.6	104.0	114.0	118.0	123.0	133.0
30	TC	82.0	79.7	74.9	72.4	69.9	64.7
	kW	5.88	6.21	6.90	7.28	7.65	8.46
	SDT	99.6	104.0	114.0	119.0	124.0	134.0
35	TC	90.4	88.0	83.0	80.4	77.8	72.4
	kW	5.98	6.31	7.02	7.40	7.78	8.59
	SDT	101.0	106.0	115.0	120.0	125.0	135.0
40	TC	99.2	96.7	91.4	88.7	85.9	80.3
	kW	6.09	6.43	7.14	7.53	7.92	8.74
	SDT	103.0	107.0	117.0	122.0	126.0	136.0
45	TC	109.0	106.0	100.0	97.4	94.5	88.6
	kW	6.22	6.56	7.28	7.68	8.07	8.91
	SDT	104.0	109.0	119.0	123.0	128.0	138.0
50	TC	118.0	116.0	110.0	107.0	104.0	97.2
	kW	6.36	6.70	7.43	7.83	8.23	9.09
	SDT	106.0	111.0	120.0	125.0	130.0	139.0

38ARZ012							
SST (F)		Air Temperature Entering Condenser (F)					
		80	85	95	100	105	115
25	TC	102.0	99.3	93.8	90.9	88.1	81.9
	kW	8.04	8.38	9.13	9.55	9.95	10.85
	SDT	101.0	106.0	116.0	121.0	126.0	136.0
30	TC	112.0	109.0	103.0	99.8	96.7	90.3
	kW	8.26	8.60	9.31	9.65	10.05	10.95
	SDT	103.0	107.0	117.0	12.02	127.0	136.0
35	TC	122.0	119.0	113.0	109.0	106.0	99.0
	kW	8.52	8.85	9.55	9.95	10.35	11.15
	SDT	104.0	109.0	118.0	123.0	128.0	137.0
40	TC	133.0	130.0	123.0	119.0	115.0	108.0
	kW	8.81	9.15	9.85	10.25	10.55	11.35
	SDT	106.0	110.0	120.0	125.0	129.0	139.0
45	TC	144.0	141.0	133.0	130.0	126.0	118.0
	kW	9.12	9.45	10.15	10.55	10.85	11.65
	SDT	108.0	112.0	122.0	126.0	131.0	140.0
50	TC	156.0	152.0	145.0	141.0	137.0	128.0
	kW	9.45	9.85	10.55	10.85	11.25	12.05
	SDT	109.0	114.0	123.0	128.0	133.0	142.0

38ARS012							
SST (F)		Air Temperature Entering Condenser (F)					
		80	85	95	100	105	115
25	TC	89.0	85.1	77.4	73.6	69.7	62.2
	kW	7.52	7.79	8.29	8.49	8.70	9.02
	SDT	103.0	108.0	118.0	123.0	128.0	138.0
30	TC	101.0	96.6	88.5	84.4	80.3	72.2
	kW	7.76	8.07	8.64	8.89	9.14	9.55
	SDT	104.0	108.0	118.0	123.0	128.0	138.0
35	TC	113.0	109.0	100.0	95.8	91.5	83.0
	kW	8.01	8.36	8.99	9.28	9.55	10.05
	SDT	105.0	109.0	119.0	124.0	128.0	138.0
40	TC	125.0	121.0	112.0	107.0	103.0	94.1
	kW	8.29	8.66	9.35	9.65	9.95	10.55
	SDT	106.0	111.0	120.0	125.0	129.0	139.0
45	TC	138.0	133.0	124.0	119.0	115.0	106.0
	kW	8.57	8.97	9.75	10.05	10.50	11.05
	SDT	108.0	113.0	122.0	127.0	131.0	140.0
50	TC	152.0	147.0	137.0	132.0	127.0	117.0
	kW	8.85	9.28	10.15	10.45	10.90	11.55
	SDT	111.0	115.0	124.0	129.0	133.0	142.0

38ARD012							
SST (F)		Air Temperature Entering Condenser (F)					
		80	85	95	100	105	115
25	TC	90.5	87.9	82.6	79.8	76.9	71.1
	kW	7.75	8.17	9.05	9.52	10.00	11.00
	SDT	100.0	105.0	115.0	120.0	125.0	135.0
30	TC	100.0	97.8	92.2	89.3	86.3	80.2
	kW	7.79	8.21	9.09	9.57	10.10	11.10
	SDT	101.0	106.0	116.0	120.0	125.0	135.0
35	TC	111.0	108.0	102	99.0	96.0	89.7
	kW	7.89	8.3	9.18	9.66	10.10	11.20
	SDT	102.0	107.0	116.0	121.0	126.0	136.0
40	TC	122.0	119.0	112	109.0	106.0	99.4
	kW	8.01	8.42	9.31	9.79	10.30	11.30
	SDT	104.0	108.0	118.0	123.0	127.0	137.0
45	TC	133.0	130.0	123	120.0	116.0	109.0
	kW	8.15	8.57	9.46	9.95	10.40	11.50
	SDT	105.0	110.0	120.0	124.0	129.0	138.0
50	TC	145.0	141.0	134	131.0	127.0	120.0
	kW	8.3	8.72	9.63	10.10	10.60	11.70
	SDT	107.0	112.0	121.0	126.0	131.0	140.0

LEGEND

- kW — Compressor Power
- SDT — Saturated Discharge Temperature at Compressor (F)
- SST — Saturated Suction Temperature (F)
- TC — Gross Cooling Capacity (1000 Btuh)

38AR007-012

Performance data (cont)



COMBINATION RATINGS

UNIT 38ARZ007*

38AR007-012

38ARZ007/40RM007H WITH HIGH-CAPACITY 4-ROW COIL

Temp (F) Air Entering Condenser (Edb)		Evaporator Air — Cfm											
		1800				2400				3000			
		Evaporator Air — Ewb (F)											
		57	62	67	72	57	62	67	72	57	62	67	72
80	TC	66.0	68.6	74.3	80.7	72.0	72.6	77.7	84.1	76.2	76.2	79.9	86.2
	SHC	66.0	60.9	51.0	40.8	72.0	70.5	58.6	45.5	76.2	76.2	65.7	50.0
	kW	4.45	4.49	4.60	4.71	4.55	4.57	4.66	4.78	4.63	4.63	4.70	4.82
85	TC	65.1	67.5	73.1	79.3	71.0	71.4	76.3	82.6	75.0	75.1	78.5	84.6
	SHC	65.1	60.3	50.5	40.3	71.0	69.8	58.1	45.0	75.0	75.1	65.2	49.5
	kW	4.72	4.76	4.87	4.99	4.83	4.84	4.93	5.05	4.91	4.90	4.97	5.09
95	TC	63.3	65.2	70.6	76.7	68.9	69.1	73.6	79.7	72.8	72.8	75.7	81.6
	SHC	63.3	59.2	49.4	39.3	68.9	68.3	57.0	44.0	72.8	72.8	64.0	48.5
	kW	5.26	5.30	5.41	5.53	5.37	5.38	5.47	5.60	5.45	5.45	5.51	5.64
100	TC	62.3	64.0	69.2	75.2	67.7	67.9	72.2	78.2	71.5	71.5	74.2	80.0
	SHC	62.3	58.6	48.9	38.8	67.7	67.4	56.5	43.5	71.5	71.5	63.4	47.9
	kW	5.57	5.61	5.71	5.84	5.68	5.68	5.78	5.90	5.76	5.76	5.82	5.95
105	TC	61.3	62.8	67.9	73.8	66.6	66.7	70.7	76.6	70.3	70.3	72.7	78.4
	SHC	61.3	58.0	48.3	38.2	66.6	66.6	55.9	42.9	70.3	70.3	62.8	47.4
	kW	5.88	5.91	6.02	6.15	5.99	5.99	6.08	6.21	6.07	6.08	6.12	6.26
115	TC	59.3	60.5	65.2	70.9	64.4	64.3	67.8	73.5	67.9	67.9	69.7	75.2
	SHC	59.3	56.8	47.2	37.2	64.4	64.3	54.8	41.9	67.9	67.9	61.6	46.4
	kW	6.51	6.53	6.63	6.77	6.61	6.61	6.70	6.83	6.69	6.70	6.74	6.88

38ARZ007/40RM007 WITH STANDARD 3-ROW COIL

Temp (F) Air Entering Condenser (Edb)		Evaporator Air — Cfm											
		1800				2400				3000			
		Evaporator Air — Ewb (F)											
		57	62	67	72	57	62	67	72	57	62	67	72
80	TC	63.4	66.1	71.7	77.8	69.0	69.8	74.9	81.1	72.9	72.9	76.9	83.1
	SHC	63.4	58.4	49.0	39.2	69.0	67.2	56.0	43.6	72.9	72.9	62.5	47.6
	kW	4.40	4.45	4.55	4.66	4.50	4.52	4.60	4.72	4.57	4.57	4.64	4.76
85	TC	62.5	65.1	70.5	76.6	68.0	68.7	73.6	79.7	71.9	71.9	75.6	81.7
	SHC	62.5	57.9	48.5	38.8	68.0	66.6	55.5	43.1	71.9	71.9	62.0	47.2
	kW	4.67	4.72	4.82	4.93	4.77	4.79	4.88	4.99	4.84	4.84	4.91	5.03
95	TC	60.8	62.9	68.2	74.1	66.1	66.5	71.1	77.0	69.7	69.8	73.1	78.9
	SHC	60.8	56.8	47.5	37.9	66.1	65.2	54.6	42.2	69.7	69.8	60.9	46.2
	kW	5.22	5.26	5.36	5.48	5.32	5.33	5.42	5.54	5.39	5.39	5.46	5.58
100	TC	59.9	61.8	67.0	72.8	65.1	65.4	69.8	75.6	68.6	68.6	71.7	77.4
	SHC	59.9	56.3	47.0	37.4	65.1	64.4	54.0	41.7	68.6	68.6	60.4	45.7
	kW	5.53	5.56	5.67	5.79	5.63	5.63	5.73	5.85	5.70	5.70	5.76	5.89
105	TC	59.0	60.7	65.7	71.4	64.0	64.2	68.5	74.1	67.5	67.5	70.3	75.9
	SHC	59.0	55.7	46.5	36.9	64.0	63.7	53.5	41.2	67.5	67.5	59.8	45.2
	kW	5.84	5.87	5.98	6.10	5.94	5.94	6.03	6.16	6.01	6.01	6.07	6.20
115	TC	57.1	58.4	63.3	68.7	61.9	61.9	65.8	71.3	65.2	65.2	67.4	72.9
	SHC	57.1	54.6	45.5	35.9	61.9	61.9	52.4	40.2	65.2	65.2	58.7	44.2
	kW	6.46	6.48	6.59	6.72	6.57	6.56	6.65	6.78	6.64	6.63	6.68	6.82

LEGEND

- Edb** — Entering Dry Bulb
- Ewb** — Entering Wet Bulb
- kW** — Compressor Motor Power Input
- SHC** — Sensible Heat Capacity (1000 Btuh) Gross
- TC** — Total Capacity (1000 Btuh) Gross

*Combinations shown in this page are ENERGY STAR® compliant.





COMBINATION RATINGS (cont)

UNIT 38ARZ007 (cont)

38ARZ007/40RM008H WITH HIGH-CAPACITY 4-ROW COIL*

Temp (F) Air Entering Condenser (Edb)		Evaporator Air — Cfm											
		2400				3000				3750			
		Evaporator Air — Ewb (F)											
		57	62	67	72	57	62	67	72	57	62	67	72
80	TC	71.9	72.9	78.3	84.8	77.7	77.7	81.3	87.6	81.6	81.6	83.4	89.4
	SHC	71.9	69.5	57.7	45.1	77.7	77.7	67.0	50.9	81.6	81.6	75.2	56.4
	kW	4.55	4.57	4.67	4.79	4.66	4.66	4.73	4.85	4.73	4.73	4.77	4.89
85	TC	70.9	71.7	76.9	83.3	76.5	76.5	79.8	86.1	80.3	80.3	81.9	87.8
	SHC	70.9	68.8	57.2	44.6	76.5	76.5	66.4	50.3	80.3	80.3	74.6	55.9
	kW	4.83	4.84	4.94	5.07	4.93	4.93	5.00	5.12	5.01	5.01	5.04	5.16
95	TC	68.8	69.3	74.2	80.4	74.1	74.1	76.9	82.9	77.7	77.8	79.0	84.5
	SHC	68.8	67.5	56.1	43.5	74.1	74.1	65.2	49.3	77.7	77.8	73.3	54.8
	kW	5.37	5.38	5.48	5.61	5.48	5.48	5.54	5.66	5.55	5.56	5.58	5.70
100	TC	67.7	68.0	72.8	78.8	72.8	72.9	75.4	81.3	76.4	76.4	77.4	82.8
	SHC	67.7	66.8	55.5	43.0	72.8	72.9	64.6	48.8	76.4	76.4	72.5	54.3
	kW	5.68	5.69	5.79	5.92	5.79	5.79	5.85	5.97	5.87	5.87	5.89	6.01
105	TC	66.5	66.8	71.3	77.3	71.6	71.6	73.9	79.6	75.0	75.0	75.9	81.1
	SHC	66.5	66.0	54.9	42.5	71.6	71.6	64.0	48.2	75.0	75.0	71.8	53.7
	kW	5.99	6.00	6.09	6.23	6.10	6.10	6.15	6.28	6.18	6.18	6.20	6.32
115	TC	64.3	64.3	68.4	74.2	69.0	69.1	70.8	76.2	72.3	72.3	72.7	77.7
	SHC	64.3	64.3	53.8	41.4	69.0	69.1	62.8	47.1	72.3	72.3	70.3	52.6
	kW	6.61	6.61	6.71	6.85	6.73	6.73	6.77	6.90	6.81	6.8	6.81	6.94

38AR007-012

38ARZ007/40RM008 WITH STANDARD 3-ROW COIL

Temp (F) Air Entering Condenser (Edb)		Evaporator Air — Cfm											
		2400				3000				3750			
		Evaporator Air — Ewb (F)											
		57	62	67	72	57	62	67	72	57	62	67	72
80	TC	68.4	69.5	74.8	81.0	73.6	73.6	77.6	83.8	77.3	77.3	79.5	85.5
	SHC	68.4	65.8	54.8	42.9	73.6	73.6	63.1	48.1	77.3	77.3	70.4	52.9
	kW	4.49	4.51	4.61	4.72	4.58	4.58	4.65	4.77	4.65	4.65	4.69	4.81
85	TC	67.4	68.4	73.6	79.7	72.6	72.6	76.3	82.4	76.1	76.1	78.2	84.0
	SHC	67.4	65.2	54.3	42.4	72.6	72.6	62.6	47.6	76.1	76.1	69.8	52.4
	kW	4.76	4.78	4.88	5.00	4.86	4.86	4.93	5.05	4.92	4.92	4.96	5.08
95	TC	65.5	66.2	71.1	77.1	70.4	70.5	73.7	79.5	73.8	73.8	75.5	81.1
	SHC	65.5	64.0	53.3	41.5	70.4	70.5	61.5	46.6	73.8	73.8	68.7	51.4
	kW	5.31	5.32	5.42	5.54	5.40	5.40	5.47	5.59	5.47	5.47	5.51	5.62
100	TC	64.5	65.1	69.7	75.6	69.3	69.3	72.3	78.0	72.6	72.6	74.0	79.5
	SHC	64.5	63.3	52.8	41.0	69.3	69.3	60.9	46.1	72.6	72.6	68.0	50.9
	kW	5.62	5.63	5.72	5.85	5.71	5.72	5.78	5.90	5.78	5.78	5.82	5.93
105	TC	63.4	63.9	68.4	74.1	68.1	68.1	70.9	76.5	71.4	71.4	72.6	77.9
	SHC	63.4	62.5	52.2	40.5	68.1	68.1	60.4	45.6	71.4	71.4	67.3	50.4
	kW	5.93	5.94	6.03	6.16	6.03	6.03	6.08	6.21	6.10	6.10	6.12	6.24
115	TC	61.4	61.6	65.8	71.2	65.9	65.8	68.0	73.4	68.9	68.9	69.7	74.8
	SHC	61.4	61.1	51.2	39.4	65.9	65.8	59.2	44.6	68.9	68.9	66.0	49.4
	kW	6.55	6.55	6.64	6.78	6.65	6.65	6.70	6.83	6.72	6.73	6.74	6.86

LEGEND

- Edb — Entering Dry Bulb
- Ewb — Entering Wet Bulb
- kW — Compressor Motor Power Input
- SHC — Sensible Heat Capacity (1000 Btuh) Gross
- TC — Total Capacity (1000 Btuh) Gross

*This combination (only) is ENERGY STAR® compliant.



Performance data (cont)



COMBINATION RATINGS (cont)

UNIT 38ARZ007 (cont)

38AR007-012

38ARZ007/28CB008													
Temp (F) Air Entering Condenser (Edb)		Evaporator Air — Cfm											
		1800				2400				3000			
		Evaporator Air — Ewb (F)											
		57	62	67	72	57	62	67	72	57	62	67	72
80	TC	60.7	64.2	69.9	76.0	66.1	67.7	73.2	79.4	70.0	70.3	75.4	81.6
	SHC	60.7	55.4	46.7	37.8	66.1	63.5	52.9	41.6	70.0	69.6	58.6	45.1
	kW	4.36	4.42	4.52	4.63	4.45	4.48	4.57	4.69	4.52	4.52	4.62	4.73
85	TC	59.9	63.2	68.8	74.8	65.2	66.6	72.0	78.1	69.0	69.3	74.2	80.2
	SHC	59.9	54.9	46.2	37.3	65.2	62.9	52.4	41.2	69.0	68.8	58.1	44.7
	kW	4.63	4.68	4.79	4.90	4.72	4.75	4.85	4.96	4.79	4.80	4.89	5.00
95	TC	58.3	61.2	66.6	72.4	63.4	64.5	69.7	75.4	67.1	67.1	71.6	77.4
	SHC	58.3	53.9	45.3	36.4	63.4	61.7	51.5	40.2	67.1	67.1	57.1	43.7
	kW	5.17	5.22	5.33	5.44	5.27	5.29	5.39	5.50	5.34	5.34	5.43	5.55
100	TC	57.5	60.1	65.5	71.1	62.5	63.3	68.4	74.1	66.0	66.1	70.3	76.0
	SHC	57.5	53.4	44.8	35.9	62.5	61.1	51.0	39.8	66.0	66.0	56.6	43.2
	kW	5.48	5.53	5.64	5.75	5.58	5.59	5.70	5.82	5.65	5.65	5.74	5.86
105	TC	56.6	59.0	64.3	69.8	61.5	62.2	67.1	72.7	65.0	65.0	68.9	74.6
	SHC	56.6	52.9	44.3	35.5	61.5	60.4	50.5	39.3	65.0	65.0	56.1	42.8
	kW	5.79	5.84	5.95	6.06	5.89	5.90	6.00	6.13	5.96	5.96	6.04	6.17
115	TC	54.9	56.9	61.9	67.3	59.6	59.9	64.6	70.0	62.9	62.8	66.3	71.8
	SHC	54.9	51.8	43.3	34.5	59.6	59.1	49.5	38.3	62.9	62.8	55.1	41.8
	kW	6.41	6.45	6.56	6.68	6.51	6.51	6.62	6.75	6.59	6.58	6.66	6.79

38ARZ007/28LA008													
Temp (F) Air Entering Condenser (Edb)		Evaporator Air — Cfm											
		1800				2400				3000			
		Evaporator Air — Ewb (F)											
		57	62	67	72	57	62	67	72	57	62	67	72
80	TC	61.7	65.0	70.7	76.8	67.2	68.5	74.1	80.3	71.1	71.3	76.2	82.4
	SHC	61.7	56.5	47.5	38.3	67.2	64.8	54.0	42.4	71.1	70.9	59.9	46.0
	kW	4.38	4.43	4.53	4.64	4.47	4.49	4.59	4.71	4.54	4.54	4.63	4.75
85	TC	60.9	64.0	69.6	75.6	66.3	67.4	72.8	78.9	70.1	70.3	74.9	81.0
	SHC	60.9	56.0	47.0	37.9	66.3	64.2	53.5	41.9	70.1	70.0	59.4	45.6
	kW	4.65	4.70	4.80	4.92	4.74	4.76	4.86	4.98	4.81	4.81	4.90	5.02
95	TC	59.2	61.9	67.4	73.2	64.4	65.3	70.4	76.2	68.2	68.2	72.3	78.2
	SHC	59.2	55.0	46.1	37.0	64.4	63.0	52.6	41.0	68.2	68.2	58.5	44.6
	kW	5.19	5.24	5.34	5.46	5.29	5.30	5.41	5.52	5.36	5.36	5.44	5.56
100	TC	58.4	60.8	66.2	71.9	63.5	64.1	69.1	74.8	67.1	67.1	71.0	76.7
	SHC	58.4	54.4	45.6	36.5	63.5	62.3	52.1	40.5	67.1	67.1	57.9	44.1
	kW	5.50	5.54	5.65	5.77	5.60	5.61	5.71	5.83	5.67	5.67	5.75	5.87
105	TC	57.5	59.8	65.0	70.6	62.5	63.0	67.8	73.5	66.0	66.0	69.6	75.3
	SHC	57.5	53.9	45.1	36.0	62.5	61.6	51.5	40.0	66.0	66.0	57.4	43.6
	kW	5.80	5.85	5.96	6.08	5.91	5.91	6.02	6.14	5.98	5.98	6.06	6.18
115	TC	55.8	57.6	62.6	68.0	60.5	60.7	65.2	70.7	63.9	63.8	66.9	72.4
	SHC	55.8	52.8	44.2	35.1	60.5	60.2	50.5	39.0	63.9	63.8	56.3	42.6
	kW	6.42	6.46	6.58	6.70	6.53	6.53	6.63	6.77	6.61	6.60	6.68	6.81

LEGEND

- Edb — Entering Dry Bulb
- Ewb — Entering Wet Bulb
- kW — Compressor Motor Power Input
- SHC — Sensible Heat Capacity (1000 Btuh) Gross
- TC — Total Capacity (1000 Btuh) Gross



COMBINATION RATINGS (cont)

UNIT 38ARZ008

38ARZ008/40RM007H WITH HIGH-CAPACITY 4-ROW COIL*

Temp (F) Air Entering Condenser (Edb)		Evaporator Air — Cfm											
		1800				2400				3000			
		Evaporator Air — Ewb (F)											
		57	62	67	72	57	62	67	72	57	62	67	72
80	TC	78.9	85.1	92.8	101.0	87.0	90.7	98.3	106.0	93.0	94.7	102.0	110.0
	SHC	77.9	69.0	59.0	48.7	87.0	79.9	66.9	53.6	93.0	89.3	74.2	58.0
	kW	5.75	5.78	5.85	5.94	5.79	5.83	5.91	6.01	5.85	5.87	5.96	6.06
85	TC	77.6	83.6	91.3	99.3	85.7	89.2	96.6	105.0	91.6	93.1	100.0	108.0
	SHC	77.0	68.3	58.3	48.0	85.7	79.1	66.3	52.9	91.6	88.4	73.5	57.4
	kW	6.10	6.13	6.20	6.30	6.14	6.18	6.26	6.37	6.20	6.22	6.31	6.41
95	TC	75.1	80.8	88.3	96.1	83.2	86.1	93.3	101.0	88.9	89.9	96.5	104.0
	SHC	75.1	66.8	56.9	46.7	83.2	77.6	64.9	51.6	88.9	86.7	72.2	56.1
	kW	6.80	6.82	6.90	7.00	6.85	6.87	6.96	7.08	6.91	6.92	7.01	7.12
100	TC	73.9	79.2	86.6	94.4	81.8	84.4	91.4	99.2	87.4	88.2	94.5	102.0
	SHC	73.8	66.0	56.2	46.1	81.8	76.7	64.1	50.9	87.4	85.7	71.4	55.3
	kW	7.20	7.21	7.29	7.40	7.24	7.26	7.36	7.47	7.30	7.31	7.40	7.52
105	TC	72.6	77.6	85.0	92.6	80.4	82.7	89.6	97.3	85.9	86.5	92.6	100.0
	SHC	72.6	65.3	55.5	45.4	80.4	75.9	63.4	50.2	85.9	84.7	70.7	54.6
	kW	7.59	7.60	7.68	7.79	7.64	7.66	7.75	7.87	7.70	7.71	7.80	7.92
115	TC	70.1	74.5	81.7	89.1	77.7	79.4	86.0	93.5	82.9	83.1	88.8	96.2
	SHC	70.1	63.7	54.0	44.0	77.7	74.3	61.9	48.8	82.9	82.7	69.2	53.2
	kW	8.38	8.38	8.47	8.58	8.43	8.44	8.53	8.66	8.48	8.49	8.58	8.71

38AR007-012

38ARZ008/40RM007 WITH STANDARD 3-ROW COIL

Temp (F) Air Entering Condenser (Edb)		Evaporator Air — Cfm											
		1800				2400				3000			
		Evaporator Air — Ewb (F)											
		57	62	67	72	57	62	67	72	57	62	67	72
80	TC	75.3	81.2	88.5	96.1	82.5	86.4	93.6	101.0	88.0	89.9	96.8	104.0
	SHC	74.3	65.8	56.3	46.4	82.5	75.7	63.5	50.9	88.0	84.1	70.0	54.9
	kW	5.77	5.82	5.91	6.00	5.84	5.88	5.97	6.07	5.90	5.93	6.01	6.12
85	TC	74.2	79.8	87.1	94.6	81.3	84.9	92.0	99.5	86.7	88.4	95.2	103.0
	SHC	73.4	65.2	55.6	45.8	81.3	75.0	62.8	50.2	86.7	83.3	69.4	54.3
	kW	6.12	6.18	6.27	6.37	6.20	6.24	6.33	6.44	6.26	6.28	6.38	6.48
95	TC	71.8	77.2	84.2	91.6	79.0	82.0	88.8	96.2	84.1	85.4	91.9	99.2
	SHC	71.6	63.8	54.3	44.6	79.0	73.6	61.5	49.0	84.1	81.7	68.1	53.0
	kW	6.83	6.89	6.98	7.10	6.91	6.95	7.05	7.17	6.99	7.00	7.10	7.22
100	TC	70.6	75.7	82.6	89.9	77.7	80.4	87.1	94.4	82.7	83.8	90.0	97.3
	SHC	70.5	63.1	53.6	43.9	77.7	72.8	60.8	48.3	82.7	80.7	67.4	52.3
	kW	7.22	7.28	7.38	7.50	7.31	7.35	7.45	7.58	7.39	7.40	7.51	7.63
105	TC	69.4	74.2	81.1	88.3	76.4	78.8	85.4	92.6	81.3	82.2	88.2	95.4
	SHC	69.4	62.4	53.0	43.3	76.4	72.0	60.1	47.7	81.3	79.8	66.7	51.7
	kW	7.61	7.67	7.78	7.91	7.70	7.75	7.86	7.99	7.79	7.80	7.91	8.04
115	TC	67.0	71.3	78.0	85.0	73.8	75.6	82.0	89.0	78.5	78.9	84.6	91.7
	SHC	67.0	60.9	51.6	41.9	73.8	70.5	58.7	46.4	78.5	77.9	65.3	50.3
	kW	8.39	8.45	8.59	8.73	8.49	8.54	8.66	8.80	8.59	8.60	8.71	8.86

LEGEND

- Edb — Entering Dry Bulb
- Ewb — Entering Wet Bulb
- kW — Compressor Motor Power Input
- SHC — Sensible Heat Capacity (1000 Btuh) Gross
- TC — Total Capacity (1000 Btuh) Gross

*This combination (only) is ENERGY STAR® compliant.



Performance data (cont)



COMBINATION RATINGS (cont)

UNIT 38ARZ008 (cont)

38AR007-012

38ARZ008/40RM008H WITH HIGH-CAPACITY 4-ROW COIL*													
Temp (F) Air Entering Condenser (Edb)		Evaporator Air — Cfm											
		2205				3000				3750			
		Evaporator Air — Ewb (F)											
		57	62	67	72	57	62	67	72	57	62	67	72
80	TC	86.0	90.4	98.0	106.0	94.1	95.7	103.0	111.0	96.9	97.8	104.0	112.0
	SHC	86.0	78.0	65.6	52.8	94.1	90.3	75.0	58.5	96.9	94.8	79.3	61.1
	kW	5.78	5.83	5.91	6.01	5.86	5.88	5.97	6.07	5.90	5.91	5.98	6.09
85	TC	84.8	88.9	96.4	104.0	92.7	94.1	101.0	109.0	95.4	96.2	102.0	110.0
	SHC	84.8	77.3	64.9	52.2	92.7	89.4	74.2	57.8	95.4	93.7	78.5	60.5
	kW	6.14	6.18	6.26	6.37	6.22	6.23	6.32	6.42	6.25	6.26	6.34	6.44
95	TC	82.3	85.8	93.1	101.0	90.0	90.9	97.3	105.0	92.6	93.1	98.7	106.0
	SHC	82.3	75.8	63.5	50.9	90.0	87.7	72.8	56.5	92.6	91.4	77.1	59.2
	kW	6.85	6.88	6.96	7.07	6.92	6.93	7.02	7.13	6.96	6.96	7.04	7.15
100	TC	81.0	84.2	91.3	99.1	88.5	89.2	95.4	103.0	91.0	91.4	96.8	104.0
	SHC	81.0	75.0	62.8	50.2	88.5	86.7	72.1	55.8	91.0	90.1	76.4	58.5
	kW	7.24	7.26	7.36	7.47	7.32	7.33	7.41	7.53	7.35	7.36	7.43	7.55
105	TC	79.6	82.5	89.6	97.2	87.0	87.5	93.5	101.0	89.5	89.7	94.9	102.0
	SHC	79.6	74.1	62.1	49.5	87.0	85.7	71.4	55.2	89.5	88.8	75.6	57.8
	kW	7.63	7.65	7.75	7.87	7.71	7.72	7.81	7.93	7.75	7.75	7.83	7.95
115	TC	77.0	79.2	86.0	93.5	83.9	84.1	89.8	97.2	86.3	86.4	91.0	98.3
	SHC	77.0	72.5	60.6	48.1	83.9	83.7	69.9	53.8	86.3	86.2	74.1	56.4
	kW	8.41	8.42	8.53	8.66	8.50	8.50	8.60	8.73	8.54	8.54	8.62	8.75

38ARZ008/40RM008 WITH STANDARD 3-ROW COIL													
Temp (F) Air Entering Condenser (Edb)		Evaporator Air — Cfm											
		2205				3000				3750			
		Evaporator Air — Ewb (F)											
		57	62	67	72	57	62	67	72	57	62	67	72
80	TC	81.7	85.9	93.2	101.0	89.0	90.8	97.5	105.0	91.6	92.6	98.8	106.0
	SHC	81.7	74.2	62.4	50.2	89.0	85.2	70.9	55.4	91.6	89.4	74.7	57.7
	kW	5.83	5.88	5.97	6.07	5.92	5.94	6.02	6.12	5.95	5.96	6.04	6.14
85	TC	80.6	84.5	91.6	99.2	87.7	89.3	95.8	103.0	90.2	91.1	97.1	105.0
	SHC	80.6	73.5	61.7	49.6	87.7	84.5	70.2	54.8	90.2	88.4	74.1	57.1
	kW	6.19	6.23	6.33	6.43	6.28	6.30	6.39	6.49	6.31	6.32	6.40	6.51
95	TC	78.3	81.7	88.5	95.9	85.2	86.3	92.5	99.9	87.6	88.2	93.8	101.0
	SHC	78.3	72.1	60.4	48.4	85.2	82.9	69.0	53.6	87.6	86.4	72.8	55.9
	kW	6.90	6.95	7.05	7.17	7.00	7.02	7.11	7.23	7.04	7.05	7.13	7.25
100	TC	77.0	80.1	86.9	94.2	83.7	84.7	90.7	98.0	86.1	86.6	91.9	99.1
	SHC	77.0	71.3	59.8	47.7	83.7	81.9	68.3	52.9	86.1	85.2	72.1	55.2
	kW	7.30	7.34	7.45	7.57	7.40	7.42	7.52	7.64	7.44	7.45	7.54	7.66
105	TC	75.7	78.6	85.2	92.4	82.3	83.0	88.9	96.1	84.6	85.0	90.1	97.2
	SHC	75.7	70.6	59.1	47.0	82.3	80.9	67.6	52.2	84.6	83.9	71.4	54.6
	kW	7.69	7.74	7.86	7.98	7.80	7.82	7.92	8.05	7.84	7.85	7.94	8.07
115	TC	73.2	75.4	81.9	88.8	79.5	79.8	85.3	92.3	81.7	81.8	86.4	93.3
	SHC	73.2	69.0	57.7	45.7	79.5	79.0	66.1	50.9	81.7	81.4	70.0	53.2
	kW	8.48	8.53	8.67	8.79	8.61	8.61	8.73	8.87	8.65	8.65	8.75	8.89

LEGEND

- Edb — Entering Dry Bulb
- Ewb — Entering Wet Bulb
- kW — Compressor Motor Power Input
- SHC — Sensible Heat Capacity (1000 Btuh) Gross
- TC — Total Capacity (1000 Btuh) Gross

*This combination only is ENERGY STAR® compliant.





COMBINATION RATINGS (cont)

UNIT 38ARZ008 (cont)

38ARZ008/40RM012H WITH HIGH-CAPACITY 4-ROW COIL													
Temp (F) Air Entering Condenser (Edb)		Evaporator Air — Cfm											
		3000				4000				5000			
		Evaporator Air — Ewb (F)											
		57	62	67	72	57	62	67	72	57	62	67	72
80	TC	97.3	98.8	106.0	114.0	105.0	105.0	110.0	118.0	110.0	110.0	113.0	120.0
	SHC	97.3	93.4	77.5	60.5	105.0	105.0	89.7	67.9	110.0	110.0	101.0	75.1
	kW	5.90	5.92	6.01	6.12	6.00	6.00	6.06	6.16	6.06	6.06	6.09	6.20
85	TC	95.8	97.1	104.0	112.0	103.0	103.0	108.0	116.0	108.0	108.0	111.0	118.0
	SHC	95.8	92.5	76.8	59.8	103.0	103.0	88.9	67.2	108.0	108.0	99.6	78.4
	kW	6.25	6.27	6.36	6.47	6.35	6.35	6.41	6.52	6.42	6.42	6.45	6.55
95	TC	92.9	93.8	100.0	108.0	100.0	100.0	104.0	112.0	105.0	105.0	107.0	114.0
	SHC	92.9	90.7	75.3	58.4	100.0	100.0	87.4	65.9	105.0	105.0	97.9	73.0
	kW	6.96	6.97	7.07	7.18	7.06	7.06	7.12	7.23	7.13	7.13	7.16	7.26
100	TC	91.3	92.0	98.3	106.0	98.3	98.3	102.0	109.0	103.0	103.0	105.0	111.0
	SHC	91.3	89.7	74.5	57.6	98.3	98.3	86.5	65.2	103.0	103.0	96.9	72.2
	kW	7.35	7.37	7.46	7.57	7.46	7.46	7.51	7.63	7.53	7.53	7.55	7.66
105	TC	89.7	90.2	96.3	104.0	96.5	96.6	99.8	107.0	101.0	101.0	102.0	109.0
	SHC	89.7	88.7	73.7	56.9	96.5	96.6	85.7	64.5	101.0	101.0	96.0	71.5
	kW	7.75	7.76	7.85	7.98	7.86	7.86	7.91	8.03	7.93	7.93	7.95	8.06
115	TC	86.6	86.6	92.3	99.9	93.0	93.0	95.6	103.0	97.4	97.3	98.2	105.0
	SHC	86.6	86.6	72.1	55.4	93.0	93.0	84.0	63.0	97.4	97.3	94.0	70.1
	kW	8.54	8.55	8.64	8.77	8.65	8.65	8.70	8.83	8.73	8.73	8.74	8.86

38AR007-012

38ARZ008/40RM012 WITH STANDARD 3-ROW COIL													
Temp (F) Air Entering Condenser (Edb)		Evaporator Air — Cfm											
		3000				4000				5000			
		Evaporator Air — Ewb (F)											
		57	62	67	72	57	62	67	72	57	62	67	72
80	TC	91.6	93.2	100.0	108.0	98.4	98.4	104.0	111.0	103.0	103.0	106.0	113.0
	SHC	91.6	87.9	73.0	57.0	98.4	98.4	83.9	63.6	103.0	103.0	93.5	69.7
	kW	5.95	5.97	6.06	6.16	6.04	6.04	6.10	6.21	6.10	6.10	6.14	6.24
85	TC	90.2	91.6	98.2	106.0	96.9	96.9	102.0	109.0	101.0	101.0	104.0	111.0
	SHC	90.2	87.0	72.3	56.4	96.9	96.9	83.1	63.0	101.0	101.0	92.6	69.1
	kW	6.31	6.33	6.42	6.53	6.40	6.40	6.47	6.58	6.47	6.46	6.50	6.61
95	TC	87.5	88.5	94.7	102.0	93.9	93.9	98.1	105.0	98.3	98.2	100.0	107.0
	SHC	87.5	85.3	70.9	55.0	93.9	93.9	81.7	61.7	98.3	98.2	91.0	67.8
	kW	7.03	7.05	7.14	7.27	7.13	7.13	7.20	7.32	7.20	7.20	7.24	7.35
100	TC	86.0	86.8	92.8	100.0	92.3	92.3	96.1	103.0	96.5	96.5	98.4	105.0
	SHC	86.0	84.3	70.2	54.3	92.3	92.3	81.0	61.0	96.5	96.5	90.1	67.1
	kW	7.44	7.45	7.55	7.68	7.54	7.54	7.61	7.73	7.61	7.61	7.65	7.76
105	TC	84.6	85.1	91.0	98.3	90.7	90.7	94.2	101.0	94.8	94.8	96.4	103.0
	SHC	84.6	83.3	69.5	53.6	90.7	90.7	80.2	60.3	94.8	94.8	89.2	66.4
	kW	7.84	7.86	7.96	8.09	7.95	7.95	8.02	8.14	8.03	8.03	8.05	8.17
115	TC	81.6	81.8	87.3	94.3	87.4	87.4	90.3	97.1	91.3	91.4	92.4	98.7
	SHC	81.6	81.3	68.1	52.2	87.4	87.4	78.8	58.9	91.3	91.4	87.4	65.1
	kW	8.65	8.66	8.77	8.9	8.77	8.77	8.83	8.97	8.85	8.85	8.87	9.00

LEGEND

- Edb — Entering Dry Bulb
- Ewb — Entering Wet Bulb
- kW — Compressor Motor Power Input
- SHC — Sensible Heat Capacity (1000 Btuh) Gross
- TC — Total Capacity (1000 Btuh) Gross

Performance data (cont)



COMBINATION RATINGS (cont)

UNIT 38ARZ008 (cont)

38AR007-012

38ARZ008/28CB012													
Temp (F) Air Entering Condenser (Edb)		Evaporator Air — Cfm											
		2250				3000				3750			
		Evaporator Air — Ewb (F)											
		57	62	67	72	57	62	67	72	57	62	67	72
80	TC	80.3	86.3	94.0	102.0	88.0	91.3	99.0	107.0	93.5	94.8	102.0	110.0
	SHC	80.3	72.1	61.1	50.0	88.0	82.7	69.0	54.9	93.5	91.4	76.0	59.1
	kW	5.81	5.88	5.98	6.08	5.90	5.94	6.04	6.15	5.97	5.99	6.09	6.19
85	TC	79.2	84.9	92.5	100.0	86.7	89.7	97.4	105.0	92.2	93.2	100.0	108.0
	SHC	79.2	71.4	60.5	49.4	86.7	82.0	68.4	54.2	92.2	90.5	75.4	58.5
	kW	6.15	6.22	6.32	6.43	6.25	6.28	6.39	6.50	6.32	6.33	6.44	6.55
95	TC	76.9	81.9	89.3	97.0	84.1	86.5	93.9	102.0	89.3	90.0	96.8	104.0
	SHC	76.9	70.0	59.1	48.0	84.1	80.4	66.9	52.9	89.3	88.5	74.0	57.2
	kW	6.88	6.95	7.06	7.18	6.98	7.02	7.13	7.25	7.06	7.07	7.18	7.30
100	TC	75.7	80.4	87.7	95.2	82.7	84.8	92.1	99.6	87.9	88.3	94.9	102.0
	SHC	75.7	69.2	58.4	47.3	82.7	79.5	66.2	52.2	87.9	87.4	73.2	56.4
	kW	7.27	7.34	7.46	7.58	7.38	7.41	7.53	7.66	7.46	7.47	7.58	7.71
105	TC	74.4	78.7	86.0	93.4	81.3	83.1	90.2	97.7	86.3	86.6	93.0	100.0
	SHC	74.4	68.5	57.7	46.6	81.3	78.6	65.5	51.5	86.3	86.1	72.5	55.7
	kW	7.68	7.74	7.87	8.00	7.79	7.82	7.94	8.08	7.87	7.88	7.99	8.13
115	TC	71.8	75.3	82.3	89.6	78.4	79.5	86.3	93.6	83.1	83.1	88.9	96.1
	SHC	71.8	66.8	56.1	45.2	78.4	76.7	63.9	50.0	83.1	83.1	70.9	54.2
	kW	8.52	8.60	8.73	8.88	8.65	8.68	8.82	8.97	8.75	8.75	8.87	9.02
125	TC	68.9	71.7	78.5	85.5	75.2	75.8	82.2	89.1	79.7	79.7	84.5	91.5
	SHC	68.9	65.1	54.6	43.7	75.2	74.4	62.3	48.4	79.7	79.7	69.3	52.7
	kW	9.43	9.50	9.66	9.83	9.58	9.60	9.75	9.92	9.69	9.69	9.81	9.98

38ARZ008/28LA012													
Temp (F) Air Entering Condenser (Edb)		Evaporator Air — Cfm											
		2250				3000				3750			
		Evaporator Air — Ewb (F)											
		57	62	67	72	57	62	67	72	57	62	67	72
80	TC	80.6	86.3	94.0	102.0	88.2	91.2	98.9	107.0	93.8	94.8	102.0	110.0
	SHC	80.6	72.7	61.5	50.1	88.2	83.3	69.4	55.1	93.8	92.0	76.6	59.5
	kW	5.82	5.88	5.98	6.08	5.90	5.94	6.04	6.15	5.97	5.99	6.08	6.20
85	TC	79.5	84.8	92.5	100.0	87.0	89.7	97.2	105.0	92.4	93.2	100.0	108.0
	SHC	79.5	72.0	60.9	49.5	87.0	82.5	68.8	54.4	92.4	91.0	75.9	58.8
	kW	6.16	6.22	6.32	6.43	6.25	6.29	6.39	6.50	6.32	6.33	6.43	6.54
95	TC	77.3	81.9	89.2	96.9	84.4	86.4	93.7	101.0	89.5	89.9	96.5	104.0
	SHC	77.3	70.5	59.5	48.2	84.4	80.9	67.3	53.0	89.5	88.8	74.5	57.4
	kW	6.89	6.95	7.06	7.18	6.99	7.02	7.13	7.25	7.07	7.07	7.18	7.30
100	TC	76.0	80.3	87.6	95.1	83.1	84.8	91.8	99.5	88.0	88.3	94.6	102.0
	SHC	76.0	69.8	58.7	47.5	83.1	80.1	66.6	52.3	88.0	87.7	73.7	56.7
	kW	7.27	7.34	7.46	7.58	7.38	7.41	7.53	7.66	7.46	7.47	7.57	7.70
105	TC	74.8	78.8	85.9	93.3	81.7	83.1	90.0	97.5	86.6	86.7	92.6	100.0
	SHC	74.8	69.0	58.0	46.8	81.7	79.2	65.9	51.6	86.6	86.4	73.0	56.0
	kW	7.68	7.75	7.86	8.00	7.80	7.82	7.94	8.07	7.88	7.88	7.99	8.12
115	TC	72.2	75.4	82.3	89.5	78.7	79.7	86.2	93.3	83.4	83.4	88.6	95.8
	SHC	72.2	67.4	56.6	45.3	78.7	77.2	64.4	50.2	83.4	83.4	71.5	54.5
	kW	8.53	8.59	8.73	8.88	8.66	8.68	8.81	8.96	8.76	8.76	8.86	9.01
125	TC	69.4	71.9	78.6	85.5	75.6	76.1	82.1	89.0	80.0	80.0	84.3	91.3
	SHC	69.4	65.7	55.0	43.9	75.6	75.0	62.9	48.7	80.0	80.0	69.9	53.0
	kW	9.44	9.50	9.66	9.83	9.59	9.61	9.75	9.92	9.70	9.70	9.80	9.97

LEGEND

- Edb — Entering Dry Bulb
- Ewb — Entering Wet Bulb
- kW — Compressor Motor Power Input
- SHC — Sensible Heat Capacity (1000 Btuh) Gross
- TC — Total Capacity (1000 Btuh) Gross



COMBINATION RATINGS (cont)

UNIT 38ARZ012

38ARZ012/40RM012H WITH HIGH-CAPACITY 4-ROW COIL

Temp (F) Air Entering Condenser (Edb)		Evaporator Air — Cfm											
		3000				4000				5000			
		Evaporator Air — Ewb (F)											
		57	62	67	72	57	62	67	72	57	62	67	72
80	TC	117.0	122.0	132.0	142.0	127.0	129.0	138.0	148.0	134.0	134.0	141.0	151.0
	SHC	117.0	106.0	88.4	70.9	127.0	122.0	101.0	78.6	134.0	134.0	113.0	85.9
	kW	8.34	8.48	8.74	9.02	8.61	8.66	8.89	9.18	8.81	8.80	9.00	9.28
85	TC	115.0	120.0	129.0	140.0	125.0	127.0	135.0	145.0	132.0	132.0	139.0	148.0
	SHC	115.0	104.0	87.5	70.0	125.0	121.0	100.0	77.6	132.0	132.0	112.0	84.9
	kW	8.72	8.85	9.11	9.40	8.99	9.04	9.27	9.56	9.19	9.19	9.38	9.67
95	TC	112.0	116.0	125.0	135.0	121.0	122.0	130.0	140.0	128.0	128.0	134.0	143.0
	SHC	112.0	102.0	85.5	68.2	121.0	119.0	98.2	75.8	128.0	128.0	110.0	83.1
	kW	9.49	9.60	9.86	10.20	9.76	9.79	10.00	10.30	9.96	9.95	10.10	10.40
100	TC	110.0	113.0	122.0	132.0	119.0	120.0	127.0	137.0	125.0	125.0	131.0	140.0
	SHC	110.0	101.0	84.4	67.1	119.0	117.0	97.1	74.8	125.0	125.0	109.0	82.1
	kW	9.90	10.00	10.30	10.60	10.20	10.20	10.40	10.70	10.40	10.40	10.50	10.80
105	TC	108.0	111.0	120.0	129.0	117.0	117.0	125.0	134.0	123.0	123.0	128.0	137.0
	SHC	108.0	100.0	83.3	66.1	117.0	116.0	96.0	73.7	123.0	123.0	108.0	81.0
	kW	10.30	10.40	10.70	11.00	10.60	10.60	10.80	11.10	10.80	10.80	10.90	11.20
115	TC	104.0	106.0	114.0	124.0	112.0	112.0	119.0	128.0	118.0	118.0	122.0	131.0
	SHC	104.0	97.7	81.2	64.0	112.0	112.0	93.8	71.7	118.0	118.0	105.0	78.9
	kW	11.10	11.20	11.50	11.70	11.40	11.40	11.60	11.90	11.60	11.60	11.70	12.00

38AR007-012

38ARZ012/40RM012 WITH STANDARD 3-ROW COIL

Temp (F) Air Entering Condenser (Edb)		Evaporator Air — Cfm											
		3000				4000				5000			
		Evaporator Air — Ewb (F)											
		57	62	67	72	57	62	67	72	57	62	67	72
80	TC	110.0	115.0	124.0	134.0	119.0	121.0	130.0	139.0	126.0	126.0	133.0	143.0
	SHC	110.0	99.4	83.3	66.8	119.0	114.0	94.6	73.6	126.0	125.0	105.0	79.9
	kW	8.19	8.32	8.55	8.82	8.41	8.48	8.70	8.96	8.59	8.60	8.80	9.06
85	TC	108.0	113.0	122.0	132.0	117.0	119.0	128.0	137.0	124.0	124.0	131.0	140.0
	SHC	108.0	98.4	82.4	66.0	117.0	113.0	93.7	72.8	124.0	123.0	104.0	79.0
	kW	8.57	8.70	8.93	9.20	8.80	8.85	9.08	9.35	8.97	8.98	9.17	9.44
95	TC	105.0	110.0	118.0	127.0	114.0	115.0	123.0	132.0	120.0	120.0	126.0	135.0
	SHC	105.0	96.6	80.7	64.3	114.0	111.0	91.9	71.1	120.0	120.0	102.0	77.3
	kW	9.34	9.45	9.69	9.96	9.57	9.61	9.83	10.10	9.73	9.74	9.93	10.20
100	TC	104.0	107.0	116.0	125.0	112.0	113.0	121.0	130.0	118.0	118.0	124.0	132.0
	SHC	104.0	95.5	79.7	63.4	112.0	109.0	90.9	70.2	118.0	118.0	101.0	76.4
	kW	9.76	9.86	10.10	10.40	9.98	10.00	10.20	10.50	10.10	10.10	10.30	10.60
105	TC	102.0	105.0	114.0	122.0	110.0	111.0	118.0	127.0	116.0	116.0	121.0	130.0
	SHC	102.0	94.4	78.7	62.4	110.0	108.0	89.9	69.2	116.0	116.0	100.0	75.5
	kW	10.20	10.30	10.5	10.80	10.40	10.40	10.60	10.90	10.60	10.60	10.70	11.00
115	TC	98.4	101.0	109.0	117.0	106.0	106.0	113.0	122.0	111.0	111.0	116.0	124.0
	SHC	98.4	92.2	76.7	60.5	106.0	105.0	87.8	67.3	111.0	111.0	97.9	73.6
	kW	11.00	11.10	11.30	11.60	11.20	11.20	11.40	11.70	11.40	11.40	11.50	11.80

LEGEND

- Edb — Entering Dry Bulb
- Ewb — Entering Wet Bulb
- kW — Compressor Motor Power Input
- SHC — Sensible Heat Capacity (1000 Btuh) Gross
- TC — Total Capacity (1000 Btuh) Gross

Performance data (cont)



COMBINATION RATINGS (cont)

UNIT 38ARZ012 (cont)

38AR007-012

38ARZ012/40RM014H WITH HIGH-CAPACITY 4-ROW COIL													
Temp (F) Air Entering Condenser (Edb)		Evaporator Air — Cfm											
		3750				5000				6250			
		Evaporator Air — Ewb (F)											
		57	62	67	72	57	62	67	72	57	62	67	72
80	TC	126.0	129.0	138.0	149.0	136.0	136.0	143.0	153.0	142.0	142.0	147.0	156.0
	SHC	126.0	119.0	98.7	77.4	136.0	135.0	114.0	86.5	142.0	142.0	127.0	95.0
	kW	8.60	8.68	8.94	9.23	8.87	8.87	9.08	9.37	9.06	9.05	9.18	9.46
85	TC	124.0	127.0	136.0	146.0	134.0	134.0	141.0	151.0	140.0	140.0	144.0	154.0
	SHC	124.0	118.0	97.7	76.5	134.0	133.0	113.0	85.6	140.0	140.0	126.0	94.1
	kW	8.98	9.05	9.31	9.61	9.25	9.25	9.46	9.76	9.44	9.44	9.56	9.84
95	TC	120.0	122.0	131.0	141.0	129.0	129.0	136.0	145.0	136.0	136.0	139.0	148.0
	SHC	120.0	116.0	95.7	74.6	129.0	129.0	111.0	83.8	136.0	136.0	124.0	92.3
	kW	9.74	9.80	10.10	10.40	10.00	10.00	10.20	10.50	10.20	10.20	10.30	10.60
100	TC	118.0	120.0	128.0	138.0	127.0	127.0	133.0	142.0	133.0	133.0	136.0	145.0
	SHC	118.0	114.0	94.6	73.6	127.0	127.0	109.0	82.7	133.0	133.0	123.0	91.2
	kW	10.20	10.20	10.50	10.80	10.40	10.40	10.60	10.90	10.60	10.60	10.70	11.00
105	TC	116.0	117.0	126.0	135.0	125.0	125.0	130.0	139.0	130.0	130.0	133.0	142.0
	SHC	116.0	113.0	93.5	72.6	125.0	125.0	108.0	81.6	130.0	130.0	121.0	90.1
	kW	10.60	10.60	10.90	11.20	10.80	10.80	11.00	11.30	11.00	11.00	11.10	11.40
115	TC	112.0	112.0	120.0	129.0	120.0	120.0	124.0	133.0	125.0	125.0	127.0	135.0
	SHC	112.0	110.0	91.4	70.5	120.0	120.0	106.0	79.5	125.0	125.0	119.0	87.9
	kW	11.40	11.40	11.70	12.00	11.60	11.70	11.80	12.10	11.80	11.80	11.90	12.20

38ARZ012/40RM014 WITH STANDARD 3-ROW COIL													
Temp (F) Air Entering Condenser (Edb)		Evaporator Air — Cfm											
		3750				5000				6250			
		Evaporator Air — Ewb (F)											
		57	62	67	72	57	62	67	72	57	62	67	72
80	TC	119.0	123.0	132.0	142.0	128.0	129.0	137.0	147.0	135.0	135.0	140.0	150.0
	SHC	119.0	112.0	93.2	73.4	128.0	127.0	106.0	81.4	135.0	135.0	118.0	88.6
	kW	8.42	8.51	8.77	9.05	8.66	8.68	8.90	9.18	8.84	8.84	8.99	9.27
85	TC	118.0	121.0	130.0	140.0	126.0	127.0	135.0	144.0	133.0	133.0	138.0	147.0
	SHC	118.0	111.0	92.3	72.5	126.0	126.0	105.0	80.5	133.0	133.0	117.0	87.8
	kW	8.80	8.89	9.14	9.43	9.05	9.06	9.28	9.56	9.22	9.22	9.37	9.65
95	TC	114.0	116.0	125.0	135.0	122.0	123.0	130.0	139.0	128.0	128.0	133.0	142.0
	SHC	114.0	109.0	90.4	70.7	122.0	122.0	103.0	78.7	128.0	128.0	115.0	86.0
	kW	9.57	9.64	9.89	10.20	9.81	9.81	10.00	10.30	9.99	9.99	10.10	10.40
100	TC	112.0	114.0	123.0	132.0	120.0	120.0	127.0	136.0	126.0	126.0	130.0	139.0
	SHC	112.0	108.0	89.3	69.7	120.0	120.0	102.0	77.7	126.0	126.0	114.0	85.0
	kW	9.98	10.00	10.30	10.60	10.20	10.20	10.40	10.70	10.40	10.40	10.50	10.80
105	TC	110.0	112.0	120.0	129.0	118.0	118.0	124.0	133.0	123.0	123.0	127.0	136.0
	SHC	110.0	106.0	88.2	68.7	118.0	118.0	101.0	76.7	123.0	123.0	113.0	84.0
	kW	10.40	10.40	10.70	11.00	10.60	10.60	10.80	11.10	10.80	10.80	10.90	11.20
115	TC	106.0	107.0	115.0	124.0	114.0	113.0	119.0	127.0	119.0	119.0	121.0	130.0
	SHC	106.0	104.0	86.1	66.6	114.0	113.0	99.1	74.6	119.0	119.0	110.0	81.9
	kW	11.20	11.20	11.50	11.80	11.40	11.40	11.60	11.90	11.60	11.60	11.70	12.00

LEGEND

- Edb — Entering Dry Bulb
- Ewb — Entering Wet Bulb
- kW — Compressor Motor Power Input
- SHC — Sensible Heat Capacity (1000 Btuh) Gross
- TC — Total Capacity (1000 Btuh) Gross



COMBINATION RATINGS (cont)

UNIT 38ARS012

38ARS012/40RM012H WITH HIGH-CAPACITY 4-ROW COIL													
Temp (F) Air Entering Condenser (Edb)		Evaporator Air — Cfm											
		3000				4000				5000			
		Evaporator Air — Ewb (F)											
		57	62	67	72	57	62	67	72	57	62	67	72
80	TC	113.0	118.0	129.0	141.0	124.0	126.0	135.0	147.0	132.0	132.0	139.0	151.0
	SHC	113.0	104.0	87.4	70.5	124.0	121.0	101.0	78.8	132.0	132.0	113.0	86.6
	kW	8.00	8.12	8.35	8.61	8.26	8.29	8.49	8.75	8.43	8.43	8.58	8.82
85	TC	111.0	115.0	126.0	137.0	122.0	123.0	132.0	144.0	129.0	129.0	136.0	148.0
	SHC	111.0	102.0	86.1	69.3	122.0	119.0	99.5	77.6	129.0	129.0	112.0	85.4
	kW	8.39	8.51	8.76	9.05	8.67	8.69	8.91	9.20	8.86	8.86	9.01	9.28
95	TC	106.0	110.0	120.0	131.0	117.0	117.0	125.0	137.0	124.0	124.0	129.0	140.0
	SHC	106.0	99.8	83.7	66.9	117.0	116.0	96.9	75.1	124.0	124.0	109.0	82.9
	kW	9.17	9.28	9.58	9.93	9.49	9.51	9.76	10.10	9.72	9.72	9.88	10.20
100	TC	104.0	107.0	117.0	128.0	114.0	114.0	122.0	133.0	121.0	121.0	126.0	137.0
	SHC	104.0	98.4	82.4	65.7	114.0	114.0	95.6	73.9	121.0	121.0	108.0	81.7
	kW	9.55	9.65	9.98	10.40	9.90	9.90	10.20	10.50	10.10	10.10	10.30	10.60
105	TC	102.0	104.0	114.0	124.0	112.0	112.0	119.0	130.0	118.0	118.0	122.0	133.0
	SHC	102.0	97.0	81.1	64.5	112.0	112.0	94.3	72.7	118.0	118.0	106.0	80.5
	kW	9.93	10.00	10.40	10.80	10.30	10.30	10.60	11.00	10.60	10.60	10.70	11.10
115	TC	97.2	98.6	107.0	118.0	106.0	106.0	112.0	122.0	113.0	113.0	116.0	125.0
	SHC	97.2	94.2	78.6	62.1	106.0	106.0	91.7	70.2	113.0	113.0	104.0	78.0
	kW	10.70	10.80	11.20	11.60	11.10	11.10	11.40	11.80	11.40	11.40	11.50	12.00

38AR007-012

38ARS012/40RM012 WITH STANDARD 3-ROW COIL													
Temp (F) Air Entering Condenser (Edb)		Evaporator Air — Cfm											
		3000				4000				5000			
		Evaporator Air — Ewb (F)											
		57	62	67	72	57	62	67	72	57	62	67	72
80	TC	107.0	112.0	123.0	134.0	118.0	119.0	129.0	140.0	125.0	125.0	133.0	144.0
	SHC	107.0	98.8	83.3	67.2	118.0	114.0	95.5	74.8	125.0	125.0	107.0	81.8
	kW	7.91	8.03	8.25	8.49	8.14	8.18	8.38	8.62	8.30	8.30	8.46	8.71
85	TC	105.0	110.0	120.0	131.0	115.0	117.0	126.0	137.0	122.0	122.0	129.0	141.0
	SHC	105.0	97.5	82.2	66.1	115.0	113.0	94.3	73.7	122.0	122.0	105.0	80.6
	kW	8.29	8.40	8.65	8.92	8.54	8.57	8.79	9.06	8.71	8.71	8.88	9.15
95	TC	101.0	105.0	114.0	125.0	111.0	111.0	120.0	131.0	117.0	117.0	123.0	134.0
	SHC	101.0	95.0	79.8	63.9	111.0	109.0	92.0	71.4	117.0	117.0	103.0	78.4
	kW	9.04	9.15	9.44	9.78	9.34	9.36	9.61	9.94	9.54	9.54	9.72	10.00
100	TC	98.9	102.0	111.0	122.0	108.0	109.0	117.0	127.0	115.0	115.0	120.0	131.0
	SHC	98.9	93.7	78.7	62.8	108.0	108.0	90.8	70.3	115.0	115.0	102.0	77.3
	kW	9.41	9.51	9.83	10.20	9.73	9.74	10.00	10.40	9.94	9.95	10.10	10.50
105	TC	96.8	99.4	108.0	119.0	106.0	106.0	113.0	124.0	112.0	112.0	117.0	127.0
	SHC	96.8	92.3	77.5	61.6	106.0	106.0	89.5	69.2	112.0	112.0	100.0	76.1
	kW	9.78	9.87	10.0	10.60	10.10	10.10	10.40	10.80	10.30	10.30	10.50	10.90
115	TC	92.5	94.1	103.0	113.0	101.0	101.0	107.0	117.0	107.0	107.0	110.0	120.0
	SHC	92.5	89.7	75.1	59.4	101.0	101.0	87.1	67.0	107.0	107.0	97.7	73.9
	kW	10.50	10.60	11.00	11.40	10.90	10.90	11.20	11.60	11.20	11.20	11.30	11.80

LEGEND

- Edb — Entering Dry Bulb
- Ewb — Entering Wet Bulb
- kW — Compressor Motor Power Input
- SHC — Sensible Heat Capacity (1000 Btuh) Gross
- TC — Total Capacity (1000 Btuh) Gross

Performance data (cont)



COMBINATION RATINGS (cont)

UNIT 38ARS012 (cont)

38AR007-012

38ARS012/40RM014H WITH HIGH-CAPACITY 4-ROW COIL													
Temp (F) Air Entering Condenser (Edb)		Evaporator Air — Cfm											
		3750				5000				6250			
		Evaporator Air — Ewb (F)											
		57	62	67	72	57	62	67	72	57	62	67	72
80	TC	122.0	125.0	135.0	147.0	133.0	133.0	141.0	153.0	141.0	141.0	145.0	157.0
	SHC	122.0	117.0	97.7	77.1	133.0	133.0	113.0	86.9	141.0	141.0	127.0	96.0
	kW	8.23	8.28	8.51	8.77	8.47	8.47	8.64	8.88	8.62	8.62	8.72	8.95
85	TC	120.0	122.0	132.0	144.0	130.0	130.0	138.0	149.0	138.0	138.0	142.0	153.0
	SHC	120.0	116.0	96.5	76.0	130.0	130.0	112.0	85.6	138.0	138.0	126.0	94.7
	kW	8.64	8.69	8.94	9.22	8.90	8.90	9.07	9.35	9.07	9.07	9.16	9.42
95	TC	115.0	116.0	126.0	137.0	125.0	125.0	131.0	142.0	132.0	132.0	135.0	145.0
	SHC	115.0	113.0	93.9	73.6	125.0	125.0	109.0	83.2	132.0	132.0	123.0	92.3
	kW	9.46	9.50	9.78	10.10	9.76	9.76	9.95	10.30	9.97	9.97	10.10	10.40
100	TC	113.0	113.0	123.0	134.0	122.0	122.0	128.0	139.0	129.0	129.0	131.0	141.0
	SHC	113.0	111.0	92.6	72.4	122.0	122.0	108.0	82.0	129.0	129.0	121.0	91.1
	kW	9.86	9.89	10.20	10.60	10.20	10.20	10.40	10.70	10.40	10.40	10.50	10.80
105	TC	110.0	111.0	119.0	130.0	119.0	119.0	124.0	135.0	126.0	126.0	128.0	138.0
	SHC	110.0	109.0	91.4	71.1	119.0	119.0	107.0	80.8	126.0	126.0	120.0	89.9
	kW	10.30	10.30	10.60	11.00	10.60	10.60	10.80	11.20	10.80	10.80	10.90	11.30
115	TC	105.0	105.0	113.0	123.0	114.0	114.0	117.0	127.0	120.0	120.0	121.0	130.0
	SHC	105.0	105.0	88.8	68.7	114.0	114.0	104.0	78.4	120.0	120.0	117.0	87.4
	kW	11.10	11.10	11.40	11.90	11.50	11.50	11.60	12.10	11.70	11.70	11.80	12.20

38ARS012/40RM014 WITH STANDARD 3-ROW COIL													
Temp (F) Air Entering Condenser (Edb)		Evaporator Air — Cfm											
		3750				5000				6250			
		Evaporator Air — Ewb (F)											
		57	62	67	72	57	62	67	72	57	62	67	72
80	TC	115.0	118.0	129.0	140.0	125.0	126.0	134.0	146.0	132.0	132.0	138.0	149.0
	SHC	115.0	110.0	92.3	73.1	125.0	125.0	106.0	81.7	132.0	132.0	119.0	89.6
	kW	8.08	8.14	8.37	8.62	8.30	8.30	8.48	8.74	8.45	8.45	8.57	8.81
85	TC	113.0	116.0	126.0	137.0	123.0	123.0	131.0	142.0	130.0	130.0	134.0	146.0
	SHC	113.0	109.0	91.1	71.9	123.0	123.0	105.0	80.5	130.0	130.0	117.0	88.5
	kW	8.47	8.53	8.78	9.06	8.71	8.72	8.91	9.18	8.88	8.88	8.99	9.26
95	TC	109.0	110.0	120.0	131.0	118.0	118.0	124.0	136.0	124.0	124.0	128.0	139.0
	SHC	109.0	106.0	88.7	69.6	118.0	118.0	102.0	78.2	124.0	124.0	114.0	86.1
	kW	9.25	9.31	9.60	9.94	9.54	9.54	9.75	10.10	9.73	9.74	9.85	10.20
100	TC	106.0	108.0	116.0	127.0	115.0	115.0	121.0	132.0	121.0	121.0	124.0	135.0
	SHC	106.0	104.0	87.5	68.5	115.0	115.0	101.0	77.0	121.0	121.0	113.0	84.9
	kW	9.64	9.68	9.99	10.40	9.95	9.95	10.10	10.50	10.20	10.20	10.30	10.60
105	TC	104.0	105.0	113.0	124.0	112.0	113.0	118.0	129.0	118.0	118.0	121.0	131.0
	SHC	104.0	103.0	86.2	67.3	112.0	113.0	99.7	75.8	118.0	118.0	111.0	83.8
	kW	10.00	10.10	10.40	10.80	10.40	10.40	10.60	10.90	10.60	10.60	10.70	11.00
115	TC	99.2	99.3	107.0	117.0	107.0	107.0	111.0	121.0	113.0	113.0	114.0	124.0
	SHC	99.2	99.3	83.7	64.9	107.0	107.0	97.1	73.5	113.0	113.0	108.0	81.4
	kW	10.80	10.80	11.20	11.60	11.20	11.20	11.40	11.80	11.40	11.40	11.50	11.90

LEGEND

- Edb — Entering Dry Bulb
- Ewb — Entering Wet Bulb
- kW — Compressor Motor Power Input
- SHC — Sensible Heat Capacity (1000 Btuh) Gross
- TC — Total Capacity (1000 Btuh) Gross



COMBINATION RATINGS (cont)

UNIT 38ARD012

38ARD012/40RM012H WITH HIGH-CAPACITY 4-ROW COIL													
Temp (F) Air Entering Condenser (Edb)		Evaporator Air — Cfm											
		3000				4000				5000			
		Evaporator Air — Ewb (F)											
		57	62	67	72	57	62	67	72	57	62	67	72
80	TC	112.0	116.0	126.0	136.0	122.0	123.0	131.0	142.0	129.0	129.0	135.0	146.0
	SHC	112.0	102.0	85.9	68.8	122.0	119.0	98.8	76.7	129.0	129.0	111.0	84.2
	kW	7.90	7.94	8.06	8.19	8.01	8.03	8.13	8.27	8.10	8.10	8.18	8.32
85	TC	110.0	114.0	123.0	134.0	120.0	121.0	129.0	140.0	127.0	127.0	133.0	143.0
	SHC	110.0	102.0	85.0	67.9	120.0	118.0	97.9	75.8	127.0	127.0	110.0	83.3
	kW	8.35	8.39	8.51	8.65	8.46	8.47	8.58	8.72	8.55	8.55	8.63	8.77
95	TC	107.0	110.0	119.0	130.0	116.0	117.0	124.0	135.0	123.0	123.0	128.0	138.0
	SHC	107.0	99.6	83.2	66.3	116.0	115.0	96.1	74.1	123.0	123.0	108.0	81.6
	kW	9.24	9.28	9.40	9.56	9.36	9.37	9.48	9.63	9.46	9.46	9.53	9.69
100	TC	105.0	108.0	117.0	127.0	114.0	115.0	122.0	132.0	121.0	121.0	125.0	135.0
	SHC	105.0	98.6	82.3	65.4	114.0	114.0	95.1	73.2	121.0	121.0	107.0	80.7
	kW	9.74	9.78	9.91	10.10	9.87	9.87	9.98	10.10	9.97	9.97	10.00	10.20
105	TC	103.0	106.0	115.0	125.0	112.0	113.0	119.0	129.0	119.0	119.0	123.0	132.0
	SHC	103.0	97.5	81.3	64.4	112.0	112.0	94.1	72.3	119.0	119.0	106.0	79.8
	kW	10.20	10.30	10.40	10.60	10.40	10.40	10.50	10.70	10.50	10.50	10.50	10.70
115	TC	99.7	102.0	110.0	120.0	108.0	108.0	115.0	124.0	115.0	114.0	118.0	127.0
	SHC	99.7	95.5	79.5	62.6	108.0	108.0	92.2	70.5	115.0	114.0	104.0	78.0
	kW	11.20	11.30	11.40	11.60	11.40	11.40	11.50	11.70	11.50	11.50	11.60	11.70

38AR007-012

38ARD012/40RM012 WITH STANDARD 3-ROW COIL													
Temp (F) Air Entering Condenser (Edb)		Evaporator Air — Cfm											
		3000				4000				5000			
		Evaporator Air — Ewb (F)											
		57	62	67	72	57	62	67	72	57	62	67	72
80	TC	106.0	110.0	119.0	130.0	115.0	116.0	125.0	135.0	121.0	121.0	128.0	138.0
	SHC	106.0	97.2	81.5	65.3	115.0	112.0	93.2	72.4	121.0	121.0	104.0	79.0
	kW	7.83	7.89	7.98	8.11	7.94	7.95	8.05	8.17	8.01	8.01	8.09	8.22
85	TC	104.0	108.0	117.0	127.0	113.0	114.0	123.0	133.0	120.0	120.0	126.0	136.0
	SHC	104.0	96.3	80.7	64.5	113.0	111.0	92.3	71.7	120.0	120.0	103.0	78.2
	kW	8.28	8.33	8.43	8.56	8.38	8.40	8.49	8.63	8.46	8.46	8.54	8.67
95	TC	101.0	105.0	114.0	123.0	110.0	111.0	118.0	128.0	116.0	116.0	122.0	131.0
	SHC	101.0	94.5	79.1	63.0	110.0	108.0	90.7	70.2	116.0	116.0	101.0	76.7
	kW	9.18	9.21	9.33	9.47	9.28	9.29	9.39	9.54	9.36	9.36	9.44	9.58
100	TC	99.7	103.0	111.0	121.0	108.0	109.0	116.0	126.0	114.0	114.0	119.0	129.0
	SHC	99.7	93.6	78.3	62.2	108.0	107.0	89.8	69.3	114.0	114.0	100.0	75.9
	kW	9.67	9.71	9.83	9.97	9.78	9.79	9.90	10.00	9.87	9.87	9.94	10.1
105	TC	98.1	101.0	109.0	119.0	106.0	107.0	114.0	123.0	112.0	112.0	117.0	126.0
	SHC	98.1	92.6	77.4	61.3	106.0	106.0	89.0	68.5	112.0	112.0	99.3	75.1
	kW	10.20	10.20	10.30	10.50	10.30	10.30	10.40	10.60	10.40	10.40	10.40	10.60
115	TC	94.9	97.1	105.0	114.0	103.0	103.0	110.0	119.0	108.0	108.0	112.0	121.0
	SHC	94.9	90.6	75.7	59.7	103.0	103.0	87.3	66.8	108.0	108.0	97.5	73.4
	kW	11.20	11.20	11.30	11.50	11.30	11.30	11.40	11.60	11.40	11.40	11.50	11.60

LEGEND

- Edb — Entering Dry Bulb
- Ewb — Entering Wet Bulb
- kW — Compressor Motor Power Input
- SHC — Sensible Heat Capacity (1000 Btuh) Gross
- TC — Total Capacity (1000 Btuh) Gross

Performance data (cont)



COMBINATION RATINGS (cont)

UNIT 38ARD012 (cont)

38AR007-012

38ARD012/40RM014H WITH HIGH-CAPACITY 4-ROW COIL													
Temp (F) Air Entering Condenser (Edb)		Evaporator Air — Cfm											
		3750				5000				6250			
		Evaporator Air — Ewb (F)											
		57	62	67	72	57	62	67	72	57	62	67	72
80	TC	121.0	123.0	132.0	143.0	131.0	131.0	138.0	148.0	140.0	138.0	143.0	153.0
	SHC	121.0	116.0	96.4	75.6	131.0	131.0	112.0	85.1	140.0	138.0	127.0	94.5
	kW	8.00	8.03	8.14	8.29	8.12	8.12	8.21	8.36	8.24	8.22	8.28	8.42
85	TC	119.0	121.0	130.0	141.0	129.0	129.0	135.0	146.0	138.0	137.0	140.0	150.0
	SHC	119.0	115.0	95.5	74.8	129.0	129.0	111.0	84.3	138.0	137.0	126.0	93.6
	kW	8.45	8.48	8.59	8.74	8.58	8.58	8.67	8.82	8.70	8.68	8.73	8.88
95	TC	115.0	117.0	125.0	136.0	125.0	125.0	131.0	141.0	134.0	133.0	135.0	145.0
	SHC	115.0	112.0	93.7	73.1	125.0	125.0	109.0	82.5	134.0	133.0	124.0	91.9
	kW	9.35	9.37	9.50	9.66	9.49	9.49	9.57	9.73	9.62	9.60	9.64	9.80
100	TC	113.0	115.0	123.0	133.0	123.0	123.0	128.0	138.0	131.0	131.0	132.0	142.0
	SHC	113.0	111.0	92.8	72.1	123.0	123.0	108.0	81.6	131.0	131.0	123.0	91.0
	kW	9.86	9.87	10.0	10.20	10.00	9.99	10.10	10.20	10.10	10.10	10.10	10.30
105	TC	112.0	113.0	121.0	131.0	121.0	121.0	125.0	135.0	129.0	129.0	130.0	139.0
	SHC	112.0	110.0	91.8	71.2	121.0	121.0	107.0	80.7	129.0	129.0	122.0	90.0
	kW	10.40	10.40	10.50	10.70	10.50	10.50	10.60	10.80	10.60	10.60	10.70	10.80
115	TC	108.0	108.0	116.0	126.0	116.0	116.0	120.0	130.0	124.0	124.0	124.0	133.0
	SHC	108.0	107.0	89.9	69.4	116.0	116.0	105.0	78.9	124.0	123.0	120.0	88.2
	kW	11.40	11.40	11.50	11.70	11.50	11.50	11.60	11.80	11.70	11.70	11.70	11.90

38ARD012/40RM014 WITH STANDARD 3-ROW COIL													
Temp (F) Air Entering Condenser (Edb)		Evaporator Air — Cfm											
		3750				5000				6250			
		Evaporator Air — Ewb (F)											
		57	62	67	72	57	62	67	72	57	62	67	72
80	TC	114.0	117.0	126.0	137.0	124.0	124.0	131.0	142.0	132.0	130.0	136.0	146.0
	SHC	114.0	109.0	91.1	71.7	124.0	124.0	105.0	80.0	132.0	130.0	118.0	88.2
	kW	7.93	7.96	8.07	8.20	8.03	8.04	8.13	8.27	8.14	8.12	8.19	8.33
85	TC	113.0	115.0	124.0	134.0	122.0	122.0	129.0	139.0	130.0	129.0	133.0	144.0
	SHC	113.0	108.0	90.2	70.8	122.0	122.0	104.0	79.2	130.0	129.0	117.0	87.4
	kW	8.37	8.40	8.51	8.65	8.49	8.49	8.58	8.72	8.59	8.57	8.64	8.78
95	TC	109.0	111.0	120.0	130.0	118.0	118.0	124.0	135.0	126.0	125.0	129.0	139.0
	SHC	109.0	106.0	88.5	69.2	118.0	118.0	102.0	77.6	126.0	125.0	115.0	85.8
	kW	9.27	9.29	9.41	9.56	9.39	9.39	9.48	9.63	9.51	9.48	9.55	9.70
100	TC	107.0	109.0	117.0	127.0	116.0	116.0	122.0	132.0	124.0	123.0	126.0	136.0
	SHC	107.0	105.0	87.6	68.3	116.0	116.0	101.0	76.7	124.0	123.0	114.0	84.9
	kW	9.77	9.79	9.91	10.10	9.90	9.89	9.99	10.10	10.00	9.99	10.10	10.20
105	TC	106.0	107.0	115.0	125.0	114.0	114.0	119.0	129.0	122.0	121.0	124.0	133.0
	SHC	106.0	103.0	86.7	67.4	114.0	114.0	100.0	75.8	122.0	121.0	113.0	84.0
	kW	10.30	10.30	10.40	10.60	10.40	10.40	10.50	10.70	10.50	10.50	10.60	10.70
115	TC	102.0	103.0	110.0	120.0	110.0	110.0	114.0	124.0	118.0	117.0	118.0	128.0
	SHC	102.0	101.0	84.8	65.7	110.0	110.0	98.1	74.1	118.0	117.0	111.0	82.3
	kW	11.30	11.30	11.40	11.60	11.40	11.40	11.50	11.70	11.50	11.50	11.60	11.70

LEGEND

- Edb — Entering Dry Bulb
- Ewb — Entering Wet Bulb
- kW — Compressor Motor Power Input
- SHC — Sensible Heat Capacity (1000 Btuh) Gross
- TC — Total Capacity (1000 Btuh) Gross

Electrical data



38ARZ007-012, 38ARS012, 38ARD012

UNIT SIZE 38AR	NOMINAL VOLTAGE V-Ph-Hz	VOLTAGE RANGE*		COMPRESSOR		FAN MOTORS (Qty 2)		FACTORY-INSTALLED OPTION	POWER SUPPLY	
		MIN	MAX	RLA	LRA	FLA (ea)	LRA (ea)		MCA	MOCP
Z007	208/230-3-60	187	254	19.2	146	0.9	1.6	NONE OR DISCONNECT	25.8	35
								CONVENIENCE OUTLET	30.6	35
	460-3-60	418	506	9.6	73	0.4	0.9	NONE OR DISCONNECT	12.8	20
								CONVENIENCE OUTLET	15.0	20
	575-3-60	523	632	7.7	58.4	0.4	0.9	NONE OR DISCONNECT	10.2	15
								CONVENIENCE OUTLET	12.0	15
	400-3-50	360	440	9.6	73	0.4	0.9	NONE OR DISCONNECT	12.8	20
								CONVENIENCE OUTLET	15.0	20
Z008	208/230-3-60	187	254	25.6	190	1.5	3.1	NONE OR DISCONNECT	35.0	60
								CONVENIENCE OUTLET	39.8	60
	460-3-60	418	506	12.8	95	0.7	1.9	NONE OR DISCONNECT	17.4	30
								CONVENIENCE OUTLET	19.6	30
	575-3-60	523	632	10.2	76	0.7	1.9	NONE OR DISCONNECT	13.8	20
								CONVENIENCE OUTLET	15.5	20
	400-3-50	360	440	12.8	95	0.7	1.9	NONE OR DISCONNECT	17.4	30
								CONVENIENCE OUTLET	19.6	30
Z012	208/230-3-60	187	254	37.8	239	1.5	3.1	NONE OR DISCONNECT	50.3	60
								CONVENIENCE OUTLET	55.1	70
	460-3-60	418	506	17.2	125	0.7	1.9	NONE OR DISCONNECT	22.9	30
								CONVENIENCE OUTLET	25.1	30
	575-3-60	523	632	13.4	80	0.7	1.9	NONE OR DISCONNECT	17.8	25
								CONVENIENCE OUTLET	19.5	25
	400-3-50	360	440	17.2	125	0.7	1.9	NONE OR DISCONNECT	22.9	30
								CONVENIENCE OUTLET	25.1	30
S012	208/230-3-60	187	254	36	198	1.5	3.1	NONE OR DISCONNECT	48.0	60
								CONVENIENCE OUTLET	52.8	70
	460-3-60	418	506	18	99	0.7	1.9	NONE OR DISCONNECT	23.9	35
								CONVENIENCE OUTLET	26.1	35
	575-3-60	523	632	14	79	0.7	1.9	NONE OR DISCONNECT	18.6	30
								CONVENIENCE OUTLET	20.3	30
	400-3-50	360	440	18	99	0.7	1.9	NONE OR DISCONNECT	23.9	35
								CONVENIENCE OUTLET	26.1	35
D012	208/230-3-60	187	254	16 ea.	125 ea.	1.5	3.1	NONE OR DISCONNECT	39.0	50
								CONVENIENCE OUTLET	43.8	50
	460-3-60	418	506	8 ea.	66.5 ea.	0.7	1.9	NONE OR DISCONNECT	19.4	25
								CONVENIENCE OUTLET	21.6	25
	575-3-60	523	632	6.4 ea.	50 ea.	0.7	1.9	NONE OR DISCONNECT	15.8	20
								CONVENIENCE OUTLET	17.5	20
	400-3-50	360	440	8 ea.	66.5 ea.	0.7	1.9	NONE OR DISCONNECT	19.4	25
								CONVENIENCE OUTLET	21.6	25

LEGEND

- FLA** — Full Load Amps
- LRA** — Locked Rotor Amps
- MCA** — Minimum Circuit Amps
- MOCP** — Maximum Overcurrent Protection
- NEC** — National Electrical Code
- RLA** — Rated Load Amps



*Units are suitable for use on electrical systems where voltage supplied to the unit terminals is not below or above the listed limits.

NOTES:

1. The MCA and MOCP values are calculated in accordance with the NEC, Article 440.
2. Motor RLA and LRA values are established in accordance with Underwriters' Laboratories (UL), Standard 1995.
3. The 575-v units are UL, Canada-listed only.
4. Convenience outlet is available as either a factory-installed option or a field-installed accessory and is 115-v, 1 ph, 60 Hz.

38AR007-012

Application data



Operating limits

Maximum outdoor temperature	115 F
Minimum return-air temperature	55 F
Maximum return-air temperature	95 F
Range of acceptable saturation suction temperature.	25 to 55 F
Maximum discharge temperature	275 F
Minimum discharge superheat	60 F

NOTES:

1. Select air handler at no less than 300 cfm/ton (nominal condensing unit capacity).
2. Total combined draw of the field-supplied liquid line solenoid valve and air handler fan contactor must not exceed 22 va. If the specified va must be exceeded, use a remote relay to control the load.

Liquid line

For applications with liquid lift greater than 20 ft, use 1/2-in. liquid line where 3/8 in. is shown; use 5/8-in. liquid line where 1/2 in. is shown. The maximum liquid lift is 60 ft.

MAXIMUM REFRIGERANT CHARGE

UNIT 38AR	R-22 (lb)
Z007	17.3
Z008	34.2
Z012	34.2
S012	34.2
D012	(2) 17.1

MINIMUM OUTDOOR-AIR OPERATING TEMPERATURE

UNIT 38AR	COND TEMP (F)	MINIMUM OUTDOOR TEMP (F)	
		Std	With Motormaster® Control
Z007	90	35	-20
Z008	90	35	
Z012	90	35	
S012*	90	35	
	80	35	
D012	90	35	

*Unit has one step of unloading.

Refrigerant piping

It is recommended that the refrigerant piping for all commercial split systems include a liquid line solenoid valve, a liquid line filter drier and a sight glass.

For refrigerant lines longer than 75 lineal ft, a liquid line solenoid and a suction accumulator are required. Refer to the Refrigerant Specialties table.

REFRIGERANT PIPING SIZES

UNIT 38AR	LINEAR LENGTH OF PIPING — FT							
	0-25		25-50		50-75		75-100	
	Line Size (in. OD)							
	L	S	L	S	L	S	L	S
Z007	3/8	1 1/8	3/8	1 1/8	3/8	1 1/8	3/8	1 1/8
Z008	3/8	1 1/8	1/2	1 1/8	1/2	1 1/8	1/2	1 1/8
Z012	1/2	1 3/8	1/2	1 3/8	1/2	1 3/8	1/2	1 3/8
S012	1/2	1 3/8	1/2	1 3/8	1/2	1 3/8	1/2	1 3/8
D012	(2) 3/8	(2) 1 1/8	(2) 3/8	(2) 1 1/8	(2) 3/8	(2) 1 1/8	(2) 3/8	(2) 1 1/8

LEGEND

L — Liquid Line S — Suction Line

NOTES:

1. Pipe sizes are based on a 2° F loss for liquid and suction lines.
2. Pipe sizes are based on the maximum linear length, shown for each column, plus a 50% allowance for fittings.
3. Charge units with R-22 in accordance with unit installation instructions.

THERMOSTATIC EXPANSION VALVE (TXV), DISTRIBUTOR, AND NOZZLE DATA

CONDENSING UNIT 38AR	INDOOR COIL	TXV PART NO.	NOZZLE CODE
Z007	28LA008 28CB008	Included P530-FE0750HCD	G8* J5†
Z008	28LA012 28CB012	Included P530-FE1000HC35D	E10* G8†

*Nozzles are factory installed and are correct for these applications.

†Replace factory-installed nozzle with part number in Nozzle Code column.

NOTE: See page 97 for 40RM TXV, distributor, and nozzle data.

FACTORY-INSTALLED NOZZLE AND DISTRIBUTOR DATA

INDOOR COIL	EVAPORATOR SECTION	COIL FACE AREA (sq ft)	SPORLAN NOZZLE PART NO.	DISTRIBUTOR* CONNECTION (in.)
28LA008	Single	7.44	G8	5/8 ODF
28LA012	Single	9.79	E10	5/8 ODF
28CB008	Single	7.37	J5	5/8 Flare
28CB012	Single	10.35	G8	7/8 ODF

LEGEND

ODF — Outside Diameter, Female

ODM — Outside Diameter, Male

*Sporlan distributors are factory installed and require Sporlan nozzles.

NOTE: See page 97 for 40RM TXV, distributor, and nozzle data.

REFRIGERANT SPECIALTIES PART NUMBERS

UNIT	LIQUID LINE SIZE (in.)	LIQUID LINE SOLENOID VALVE (LLSV)	LLSV COIL	SIGHT GLASS	FILTER DRIER	SUCTION LINE ACCUMULATOR
38ARZ007	3/8	200RB5T3M	AMG/24V	AMI-1TT3	P502-8304S*	S-7063S*
38ARZ008	3/8	200RB5T3M	AMG/24V	AMI-1TT3	P502-8304S*	S-7063S*
	1/2	200RB5T4M	AMG/24V	AMI-1TT4	P502-8304S	S-7063S*
38ARZ012	1/2	200RB6T4M	AMG/24V	AMI-1TT4	P502-8307S*	S-7063
38ARS012	1/2	200RB6T4M	AMG/24V	AMI-1TT4	P502-8307S*	S-7063
38ARD012	3/8	200RB5T3M Qty 2	AMG/24V Qty 2	AMI-1TT4 Qty 2	P502-8304S* Qty 2	S-7061 Qty 2

*Bushings required.

38AR007-012

Typical piping and wiring



ROOFTOP INSTALLATION — 38ARZ007-012, 38ARS012, 38ARD012

38AR007-012

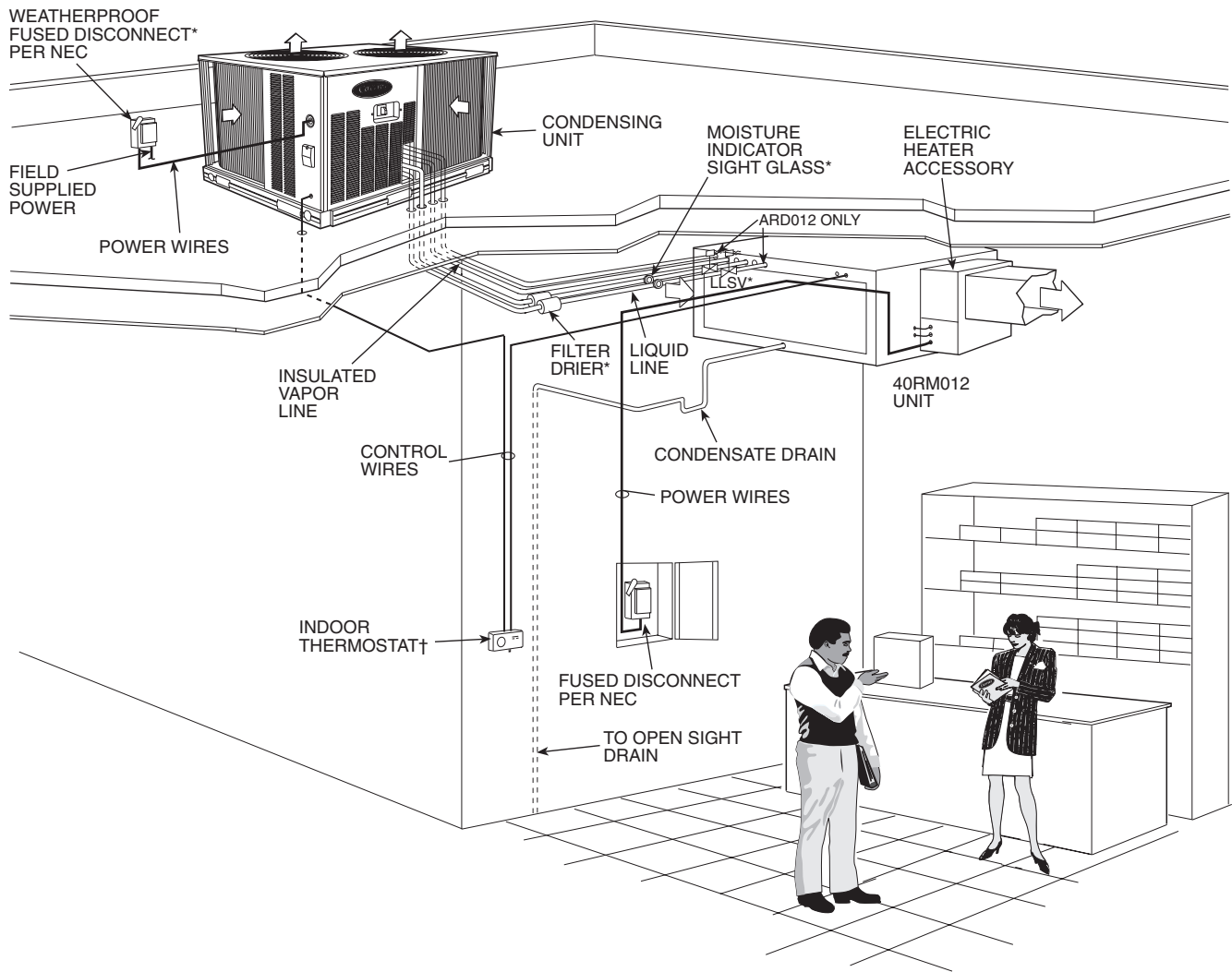

LEGEND

- LLSV** — Liquid Line Solenoid Valve
- NEC** — National Electrical Code
- TXV** — Thermostatic Expansion Valve

*Field supplied. (See Refrigerant Specialties table on page 34).

†Accessory item.

NOTES:

1. All piping must follow standard refrigerant piping techniques. Refer to Carrier System Design Manual for details.
2. All wiring must comply with the applicable local and national codes.
3. Wiring and piping shown are general points-of-connection guides only and are not intended for, or to include all details for, a specific installation.
4. Liquid line solenoid valve (solenoid drop control) is recommended to prevent refrigerant migration to the compressor.
5. Internal factory-supplied TXVs not shown.

Guide specifications — 38ARZ007-012, 38ARS012



Commercial Air-Cooled Condensing Units

HVAC Guide Specifications

Size Range: **6 to 10 Tons, Nominal**

Carrier Model Numbers: **38ARZ, Sizes 007-012**
38ARS, Size 012

Part 1 — General

1.01 SYSTEM DESCRIPTION

Outdoor-mounted, air-cooled condensing unit suitable for on-the-ground or rooftop installation. Unit shall consist of a reciprocating or scroll air-conditioning compressor assembly, an air-cooled coil, propeller-type condenser fans, and a control box. Unit shall discharge supply air upward as shown on contract drawings. Unit shall be used in a refrigeration circuit matched with a packaged air-handling unit.

1.02 QUALITY ASSURANCE

- A. Unit shall be rated in accordance with ARI Standard 210/240, 1994.
- B. Unit construction shall comply with ANSI/ASHRAE 15 safety code latest revision and comply with NEC.
- C. Unit shall be constructed in accordance with UL 1995 standard and shall carry the UL and UL, Canada label.
- D. Unit cabinet shall be capable of withstanding 500-hour salt spray exposure per ASTM B117 (scribed specimen).
- E. Air-cooled condenser coils for semi-hermetic compressor units (38ARS) shall be leak tested at 150 psig and pressure tested at 480 psig. Air-cooled condenser coils for hermetic compressor units (38ARZ) shall be leak tested at 200 psig, and pressure tested at 428 psig.
- F. Unit shall be manufactured in a facility registered to ISO 9001:2000 manufacturing quality standard.

1.03 DELIVERY, STORAGE, AND HANDLING

Unit shall be shipped as single package only, and shall be stored and handled according to unit manufacturer's recommendations.

1.04 WARRANTY (FOR INCLUSION BY SPECIFYING ENGINEER.)

Part 2 — Products

2.01 EQUIPMENT

A. General:

Factory-assembled, single piece, air-cooled condensing unit. Contained within the unit enclosure shall be all factory wiring, piping, controls, compressor, holding charge (R-22), and special features required prior to field start-up.

B. Unit Cabinet:

1. Unit cabinet shall be constructed of galvanized steel, bonderized and coated with a prepainted baked enamel finish.

2. A heavy-gage roll-formed perimeter base rail with forklift slots and lifting holes shall be provided to facilitate rigging.

C. Fans:

1. Condenser fans shall be direct driven, propeller-type, discharging air vertically upward.
2. Fan blades shall be balanced.
3. Condenser fan discharge openings shall be equipped with PVC coated steel wire safety guards.
4. Condenser fan and motor shaft shall be corrosion resistant.

D. Compressor:

1. Compressor shall be of the hermetic scroll type (ARZ) or semi-hermetic reciprocating type (ARS).
2. Compressor shall be mounted on vibration isolators.
3. Compressors shall include overload protection.
4. Compressors shall be equipped with a crank-case heater.
5. Compressor shall be equipped with internal high discharge temperature protection (38ARZ007 and 012 only).
6. Compressor shall unload using suction cutoff unloading (38ARS012). Electric solenoid unloading available as an accessory.

E. Condenser Coil:

1. Condenser coil shall be air-cooled and circuited for integral subcooler.
2. Coil shall be constructed of aluminum fins (copper fins optional) mechanically bonded to internally grooved seamless copper tubes which are then cleaned, dehydrated, and sealed.

F. Refrigeration Components:

Refrigeration circuit components shall include liquid line service valve, suction line service valve, a full charge of compressor oil, and a holding charge of refrigerant. Units with semi-hermetic compressors (38ARS) shall have oil-level sight glass and muffler.

G. Controls and Safeties:

1. Minimum control functions shall include:
 - a. Control wire terminal blocks.
 - b. Compressor lockout on auto-reset safety until reset from thermostat.
2. Minimum safety devices which are equipped with automatic reset (after resetting first at thermostat), shall include:
 - a. High discharge pressure cutout.
 - b. Low pressure cutout.
 - c. High discharge temperature cutout (38ARZ008 only).



H. Operating Characteristics:

1. The capacity of the condensing unit shall meet or exceed _____ Btuh at a suction temperature of _____ F. The power consumption at full load shall not exceed _____ kW.
2. The combination of the condensing unit and the evaporator or fan coil unit shall have a total net cooling capacity of _____ Btuh or greater at conditions of _____ cfm entering-air temperature at the evaporator at _____ F wet bulb and _____ F dry bulb, and air entering the condensing unit at _____ F.
3. The system shall have an EER of _____ Btuh/Watt or greater at standard ARI conditions.

I. Electrical Requirements:

1. Nominal unit electrical characteristics shall be _____ v, 3-ph, 60 Hz. The unit shall be capable of satisfactory operation within voltage limits of _____ v to _____ v.
2. Unit electrical power shall be single-point connection.
3. Unit control circuit shall contain a 24-v transformer for unit control.

J. Special Features:

1. Low-Ambient Temperature Control:

A low-ambient temperature control shall be available as a factory-installed option or as a field-installed accessory. This low-ambient control shall regulate speed of the condenser-fan motors in response to the saturated condensing temperature of the unit. The control shall maintain correct condensing pressure at outdoor temperatures down to -20 F.

2. Gage Panel Package:

Gage panel package shall include a suction and discharge pressure gage.

3. Optional Condenser Coil Materials:

a. Pre-Coated Aluminum-Fin Coils:

Shall have a durable epoxy-phenolic coating to provide protection in mildly corrosive coastal environments. Coating shall be applied to the aluminum fin stock prior to the fin stamping process to create an inert barrier between the aluminum fin and copper tube. Epoxy-phenolic barrier shall minimize galvanic action between dissimilar metals.

b. Copper-Fin Coils:

Shall be constructed of copper-fins mechanically bonded to copper-tubes and copper tube sheets. Galvanized steel tube sheets shall not be acceptable. A polymer strip shall prevent coil assembly from contacting sheet metal coil pan to minimize potential for galvanic corrosion between the coil and pan.

All copper construction shall provide protection in moderate coastal environments.

c. E-Coated Aluminum-Fin Coils:

Shall have a flexible epoxy polymer coating uniformly applied to all coil surface areas without material bridging between fins. Coating process shall ensure complete coil encapsulation. Color shall be high gloss black with gloss requirements of 60° of 65 to 90% per ASTM D523-89. Uniform dry film thickness from 0.8 to 1.2 mil on all surface areas including fin edges. Superior hardness characteristics of 2H per ASTM D3363-92A and cross hatch adhesion of 4B-5B per ASTM D3359-93. Impact resistance shall be up to 160 in./lb (ASTM D2794-93). Humidity and water immersion resistance shall be up to a minimum of 1000 and 250 hours respectively (ASTM D2247-92 and ASTM D870-92). Corrosion durability shall be confirmed through testing to no less than 1000 hours salt spray per ASTM B117-90. Coil construction shall be aluminum fins mechanically bonded to copper tubes.

d. E-Coated Copper-Fin Coils:

Shall have a flexible epoxy polymer coating uniformly applied to all coil surface areas without material bridging between fins. Coating process shall ensure complete coil encapsulation. Color shall be high gloss black with gloss requirements of 60° of 65 to 90% per ASTM D523-89. Uniform dry film thickness from 0.8 to 1.2 mil on all surface areas including fin edges. Superior hardness characteristics of 2H per ASTM D3363-92A and cross hatch adhesion of 4B-5B per ASTM D3359-93. Impact resistance shall be up to 160 in./lb (ASTM D2794-93). Humidity and water immersion resistance shall be up to a minimum of 1000 and 250 hours respectively (ASTM D2247-92 and ASTM D870-92). Corrosion durability shall be confirmed through testing to no less than 1000 hours salt spray per ASTM B117-90. Coil construction shall be copper-fins mechanically bonded to copper-tubes with copper tube sheets. Galvanized steel tube sheets shall not be acceptable. A polymer strip shall prevent coil assembly from contacting sheet metal coil pan to maintain coating integrity and minimize corrosion potential between the coil and pan.

4. Unit-Mounted, Non-Fused Disconnect Switch:

Shall be factory-installed, internally mounted. NEC and UL approved non-fused switch shall provide unit power shutoff. Shall be accessible from outside the unit and shall provide power off lockout capability.

Guide specifications — 38ARZ007-012, 38ARS012 (cont)



38AR007-012

5. Convenience Outlet:

Shall be factory-installed and internally mounted with easily accessible 115-v female receptacle. Shall include 15 amp GFI receptacle with independent fuse protection. Voltage required to operate convenience outlet shall be provided by a factory-installed step-down transformer. Shall be accessible from outside the unit.

6. Thermostat Controls:

a. Programmable multi-stage thermostat with 7-day clock, holiday scheduling, large backlit display, remote sensor capability, and Title 24 compliance.

b. Commercial Electronic Thermostat with 7-day timeclock, auto-changeover, multi-stage capability, and large LCD temperature display.

c. Carrier PremierLink™ Controller:

This control will function with CCN and ComfortVIEW™ software. It shall also be compatible with *ComfortLink*™ controllers. It shall be ASHRAE 62-99 compliant and Internet ready. It shall accept a CO₂ sensor in the conditioned space and be Demand Control Ventilation (DCV) ready. The communication rate must be 38.4K or faster. It shall include an integrated economizer controller.

7. Hail Guard Package:

Hail guard package shall protect coils against damage from hail and other flying debris.

8. Condenser Coil Grille:

Grille shall add decorative appearance to unit and protect condenser coil after installation.

9. Electric Solenoid Unloader:

Electric unloader valve piston, coil, and hardware shall be supplied to convert the pressure-operated compressor unloader to electric unloading (38ARS012 only).

Commercial Air-Cooled Condensing Units

HVAC Guide Specifications

Size Range: **10 Tons, Nominal**

Carrier Model Number: **38ARD, Size 012**

Part 1 — General

1.01 SYSTEM DESCRIPTION

Outdoor-mounted, air-cooled condensing unit suitable for on-the-ground or rooftop installation. Unit shall have 2 independent refrigeration circuits. Unit shall consist of dual scroll compressors, air-cooled coils, propeller-type condenser fans, and a control box. Unit shall discharge supply air upward as shown on contract drawings. Unit shall be used in a refrigeration circuit matched with a packaged air-handling unit.

1.02 QUALITY ASSURANCE

- A. Unit shall be rated in accordance with ARI Standard 210/240, latest revision.
- B. Unit construction shall comply with ANSI/ASHRAE 15 safety code latest revision and comply with NEC.
- C. Unit shall be constructed in accordance with UL 1995 standard and shall carry the UL and UL, Canada label.
- D. Unit cabinet shall be capable of withstanding 500-hour salt spray exposure per ASTM B117 (scribed specimen).
- E. Air-cooled condenser coils shall be leak tested at 200 psig, and pressure tested at 428 psig.
- F. Unit shall be manufactured in a facility registered to ISO 9001:2000 manufacturing quality standard.

1.03 DELIVERY, STORAGE, AND HANDLING

Unit shall be shipped as single package only, and shall be stored and handled according to unit manufacturer's recommendations.

1.04 WARRANTY (FOR INCLUSION BY SPECIFYING ENGINEER.)

Part 2 — Products

2.01 EQUIPMENT

A. General:

Factory-assembled, single piece, air-cooled condensing unit. Contained within the unit enclosure shall be all factory wiring, piping, controls, compressor, holding charge (R-22), and special features required prior to field start-up.

B. Unit Cabinet:

1. Unit cabinet shall be constructed of galvanized steel, bonderized and coated with a prepainted baked enamel finish.
2. A heavy-gage roll-formed perimeter base rail with forklift slots and lifting holes shall be provided to facilitate rigging.

C. Fans:

1. Condenser fans shall be direct driven, propeller-type, discharging air vertically upward.
2. Fan blades shall be balanced.
3. Condenser fan discharge openings shall be equipped with PVC coated steel wire safety guards.
4. Condenser fan and motor shaft shall be corrosion resistant.

D. Compressor:

1. Compressors shall be of the hermetic scroll type.
2. Compressors shall be mounted on vibration isolators.
3. Compressors shall include overload protection.
4. Compressors shall be equipped with a crank-case heater.
5. Compressors shall be equipped with high discharge temperature protection.

E. Condenser Coil:

1. Condenser coil shall be air-cooled and circuited for integral subcooler.
2. Coil shall be constructed of aluminum fins (copper fins optional) mechanically bonded to internally grooved seamless copper tubes which are then cleaned, dehydrated, and sealed.

F. Refrigeration Components:

Refrigeration circuit components shall include liquid line service valve, suction line service valve, a full charge of compressor oil, and a holding charge of refrigerant.

G. Controls and Safeties:

1. Minimum control functions shall include:
 - a. Control wire terminal blocks.
 - b. Compressor lockout on auto-reset safety until reset from thermostat.
2. Minimum safety devices which are equipped with automatic reset (after resetting first at thermostat), shall include:
 - a. High discharge pressure cutout.
 - b. Low pressure cutout.

H. Operating Characteristics:

1. The capacity of the condensing unit shall meet or exceed ____ Btuh at a suction temperature of ____ F. The power consumption at full load shall not exceed ____ kW.
2. The combination of the condensing unit and the evaporator or fan coil unit shall have a total net cooling capacity of ____ Btuh or greater at conditions of ____ cfm entering-air temperature at the evaporator at ____ F wet bulb and ____ F dry bulb, and air entering the condensing unit at ____ F.



3. The system shall have an EER of _____ Btuh/Watt or greater at standard ARI conditions.

I. Electrical Requirements:

1. Nominal unit electrical characteristics shall be _____ v, 3-ph, 60 Hz. The unit shall be capable of satisfactory operation within voltage limits of _____ v to _____ v.
2. Unit electrical power shall be single-point connection.
3. Unit control circuit shall contain a 24-v transformer for unit control.

J. Special Features:

1. Low-Ambient Temperature Control:

A low-ambient temperature control shall be available as a factory-installed option or as a field-installed accessory. This low-ambient control shall regulate speed of the condenser-fan motors in response to the saturated condensing temperature of the unit. The control shall maintain correct condensing pressure at outdoor temperatures down to -20 F.

2. Gage Panel Package:

Gage panel package shall include a suction and discharge pressure gage.

3. Optional Condenser Coil Materials:

a. Pre-Coated Aluminum-Fin Coils:

Shall have a durable epoxy-phenolic coating to provide protection in mildly corrosive coastal environments. Coating shall be applied to the aluminum fin stock prior to the fin stamping process to create an inert barrier between the aluminum fin and copper tube. Epoxy-phenolic barrier shall minimize galvanic action between dissimilar metals.

b. Copper-Fin Coils:

Shall be constructed of copper-fins mechanically bonded to copper-tubes and copper tube sheets. Galvanized steel tube sheets shall not be acceptable. A polymer strip shall prevent coil assembly from contacting sheet metal coil pan to minimize potential for galvanic corrosion between the coil and pan. All copper construction shall provide protection in moderate coastal environments.

c. E-Coated Aluminum-Fin Coils:

Shall have a flexible epoxy polymer coating uniformly applied to all coil surface areas without material bridging between fins. Coating process shall ensure complete coil encapsulation. Color shall be high gloss black with gloss requirements of 60° of 65 to 90% per ASTM D523-89. Uniform dry film thickness from 0.8 to 1.2 mil on all surface areas including fin edges. Superior hardness characteristics of 2H per ASTM D3363-92A and cross hatch adhesion of

4B-5B per ASTM D3359-93. Impact resistance shall be up to 160 in./lb (ASTM D2794-93). Humidity and water immersion resistance shall be up to a minimum of 1000 and 250 hours respectively (ASTM D2247-92 and ASTM D870-92). Corrosion durability shall be confirmed through testing to no less than 1000 hours salt spray per ASTM B117-90. Coil construction shall be aluminum fins mechanically bonded to copper tubes.

d. E-Coated Copper-Fin Coils:

Shall have a flexible epoxy polymer coating uniformly applied to all coil surface areas without material bridging between fins. Coating process shall ensure complete coil encapsulation. Color shall be high gloss black with gloss requirements of 60° of 65 to 90% per ASTM D523-89. Uniform dry film thickness from 0.8 to 1.2 mil on all surface areas including fin edges. Superior hardness characteristics of 2H per ASTM D3363-92A and cross hatch adhesion of 4B-5B per ASTM D3359-93. Impact resistance shall be up to 160 in./lb (ASTM D2794-93). Humidity and water immersion resistance shall be up to a minimum of 1000 and 250 hours respectively (ASTM D2247-92 and ASTM D870-92). Corrosion durability shall be confirmed through testing to no less than 1000 hours salt spray per ASTM B117-90. Coil construction shall be copper-fins mechanically bonded to copper tubes with copper tube sheets. Galvanized steel tube sheets shall not be acceptable. A polymer strip shall prevent coil assembly from contacting sheet metal coil pan to maintain coating integrity and minimize corrosion potential between the coil and pan.

4. Thermostat Controls:

a. Programmable multi-stage thermostat with 7-day clock, holiday scheduling, large backlit display, remote sensor capability, and Title 24 compliance.

b. Commercial Electronic Thermostat with 7-day timeclock, auto-changeover, multi-stage capability, and large LCD temperature display.

c. Carrier PremierLink™ Controls:

This control will function with CCN and ComfortVIEW™ software. It shall also be compatible with ComfortLink™ controllers. It shall be ASHRAE 62-99 compliant and Internet ready. It shall accept a CO₂ sensor in the conditioned space and be Demand Control Ventilation (DCV) ready. The communication rate must be 38.4K or faster. It shall include an integrated economizer controller.



5. Hail Guard Package:
Hail guard package shall protect coils against damage from hail and other flying debris.
6. Unit-Mounted, Non-Fused Disconnect Switch:
Shall be factory-installed, internally mounted. NEC and UL approved non-fused switch shall provide unit power shutoff. Shall be accessible from outside the unit and shall provide power off lockout capability.

7. Convenience Outlet:
Shall be factory-installed and internally mounted with easily accessible 115-v female receptacle. Shall include 15 amp GFI receptacle with independent fuse protection. Voltage required to operate convenience outlet shall be provided by a factory-installed step-down transformer. Shall be accessible from outside the unit.

38AR007-012

Model number nomenclature — 38ARD,AKS014-024 units



38AKS 014 -- - 5 0 1 --

38ARD – Commercial Air-Cooled
Condensing Units Dual
Circuit Scroll Compressor
38AKS – Commercial Air-Cooled
Condensing Units (Semi-Hermetic)

Nominal Tons
014 – 12-1/2
016 – 15
024 – 20

Not Used

Condenser Coil Fin Material
– – Aluminum (Standard)
C – Copper
K – Pre-Coated Aluminum Fins
E – E-Coated Al Fin/Cu Tube
F – E-Coated Cu Fin/Cu Tube

LEGEND

Al – Aluminum
Cu – Copper

Factory-Installed Options

Packaging
0 – Base Unit
1 – Domestic
3 – Export

Revision Number
0 – Original

Voltage Designation
5 – 208/230-3-60
6 – 460-3-60
1 – 575-3-60
2 – 380-3-60 (AKS Units-Export Only)

38ARD,AKS014-024

Quality Assurance

Certified to ISO 9001:2000

Physical data



38ARD014-024

UNIT SIZE 38AR	D014	D016	D024
NOMINAL CAPACITY (tons)	12 ¹ / ₂	15	20
OPERATING WEIGHTS (lb)			
Aluminum-Fin Coil (Standard)	676	740	764
Copper-Fin Coil (Optional)	822	886	904
REFRIGERANT TYPE*		R-22	
Operating Charge, Typical (lb)†	23	23	28
Shipping Charge (lb)	3.1	3.1	3.1
COMPRESSOR		Scroll	
Qty...Model	2...ZR72	2...ZR94	2...ZR125
Speed (rpm)	3500	3500	3500
Oil Charge (oz)	60 (ea)	85 (ea)	110 (ea)
Crankcase Heater Watts		70	
CONDENSER FANS		2...1075	
Qty...Rpm		26	
Diameter (in.)		1 ¹ / ₂	
Nominal Hp		11,000	
Nominal Airflow (cfm, total)		1460	
Watts (total)			
CONDENSER COIL		3...15	
Rows...Fins/in.		29.2	
Face Area (sq ft)		48	
Storage Capacity (lb)**			
CONTROLS			
Pressurestat (psig)			
High Pressure			
Cutout		426 ± 7	
Cut-in		320 ± 20	
Low Pressure			
Cutout		27 ± 4	
Cut-in		67 ± 7	
FAN CYCLING CONTROLS			
Operating Pressure (psig)			
No. 2 Fan, Close		255 ± 10	
Open		160 ± 10	
PRESSURE RELIEF			
Location		Liquid Line	
Temperature (F)		200	
PIPING CONNECTIONS (in. ODM)			
Suction		(2) 1 ³ / ₈	
Liquid		(2) 1 ¹ / ₂	
Hot Gas Stub		3 ³ / ₈	

*Unit is factory-supplied with holding charge only.

†Typical operating charge with 25 ft of interconnecting piping. Operating charge is approximate for maximum system capacity.

**Storage capacity is measured at liquid saturated temperatures of 120 F.

38ARD,AKS014-024

Physical data (cont)



38AKS014-024

UNIT SIZE 38AK	S014	S016	S024
NOMINAL CAPACITY (tons)	12½	15	20
OPERATING WEIGHTS (lb)			
Aluminum-Fin Coil (Standard)	779	789	929
Copper-Fin Coil (Optional)	919	929	1040
REFRIGERANT TYPE*		R-22	
Operating Charge, Typical (lb)†	23	23	28
Shipping Charge (lb)	3.1	3.1	3.1
COMPRESSOR		Reciprocating, Semi-Hermetic	
Qty...Model	1...06DD328	1...06DD537	1...06E4250
No. Cylinders	6	6	4
Speed (rpm)		1750	
Oil Charge (pt)	10	10	15.5
Capacity Steps			
Accessory Standard	33**, 66, 100	33**, 66, 100	—
Standard	66, 100	66, 100	50, 100
Unloader Setting (psig)			
Load		70 ± 1	
Unload		60 ± 2	
Crankcase Heater Watts		125	
CONDENSER FANS		Axial Flow, Direct Drive	
Qty...Rpm		2...1075	
Diameter (in.)		26	
Nominal Hp		½	
Nominal Airflow (cfm, total)		11,000	
Watts (total)		1460	
CONDENSER COIL		Copper Tubes, Aluminum Fins	
Rows...Fins/in.	3...15	3...15	3...15
Face Area (sq ft)	29.2	29.2	29.2
Storage Capacity (lb)††	48	48	48
CONTROLS			
Pressurestat (psig)			
High Pressure			
Cutout		395 ± 10	
Cut-in		295 ± 20	
Low Pressure			
Cutout		27 ± 4	
Cut-in		67 ± 7	
FAN CYCLING CONTROLS			
Operating Pressure (psig)			
No. 2 Fan, Close		255 ± 10	
Open		160 ± 10	
PRESSURE RELIEF			
Location		Liquid Line	
Temperature (F)		200	
PIPING CONNECTIONS (in. ODM)			
Suction	1¾	1¾	1⅝
Liquid		⅝	
Hot Gas Stub		⅜	

*Unit is factory-supplied with holding charge only.

†Typical operating charge with 25 ft of interconnecting piping. Operating charge is approximate for maximum system capacity.

**Indicates capacity step (%) with electric unloader accessory.

††Storage capacity is measured at liquid saturated temperatures of 120 F.

38ARD_AKS014-024

Dimensions



38AKS014-024

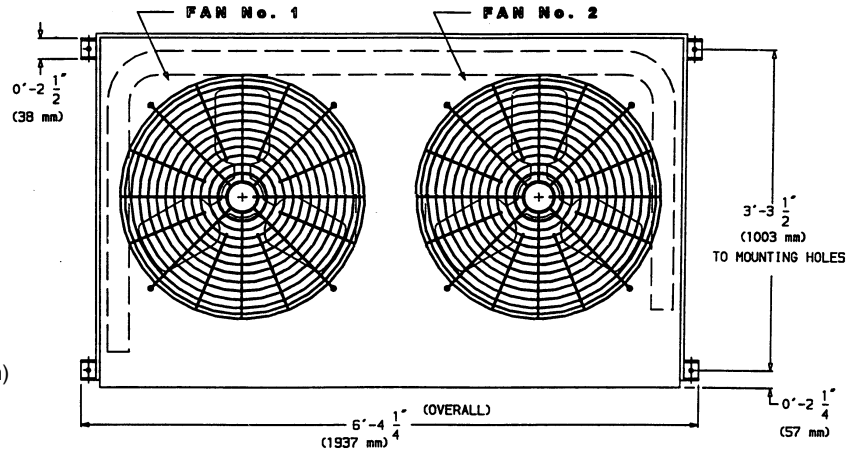

TOP VIEW

NOTES:

- Service clearances are as follows:
 Side (compressor) — 3 1/2 ft (1067 mm)
 Side (opposite compressor) — 3 ft (914 mm)
 Ends — 2 ft (610 mm)
 Top — 5 ft (1524 mm)
- See page 47 for corner weights and unit center of gravity.

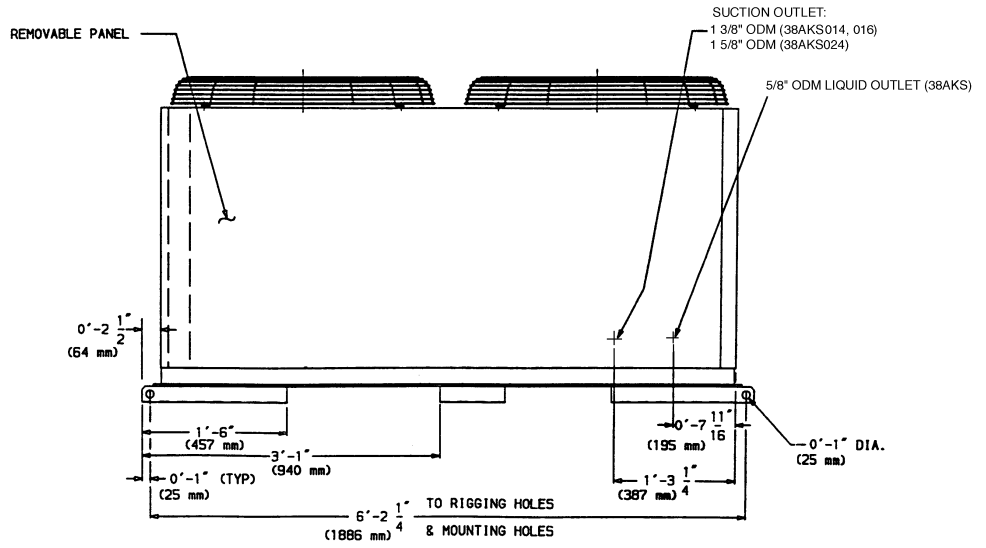

SIDE VIEW

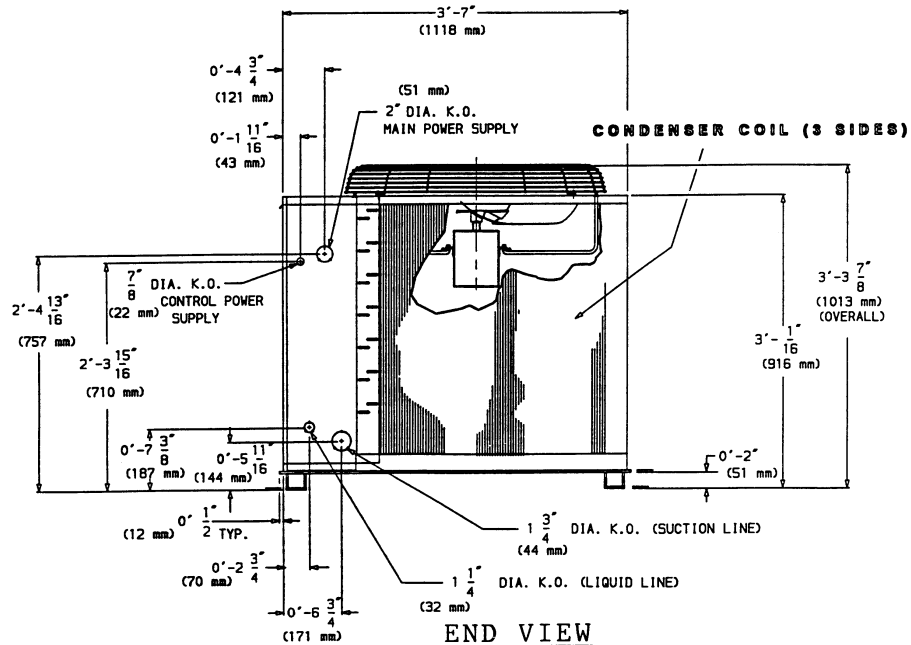

END VIEW

38AKS014-024

Dimensions (cont)



38ARD014-024

NOTES:

- Service clearances are as follows:
 Side (compressor) — 3 1/2 ft (1067 mm)
 Side (opposite compressor) — 3 ft (914 mm)
 Ends — 2 ft (610 mm)
 Top — 5 ft (1524 mm)
- See page 47 for corner weights and unit center of gravity.

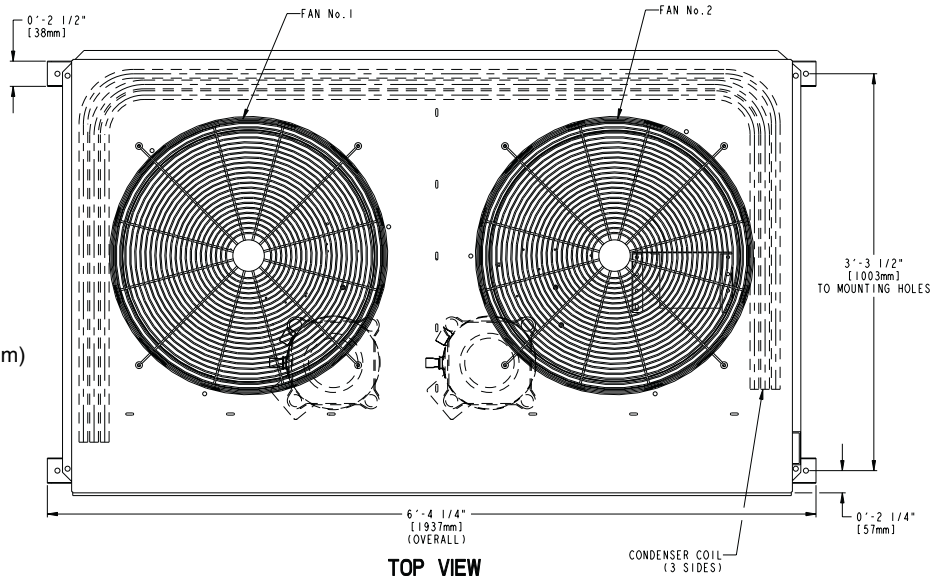

TOP VIEW

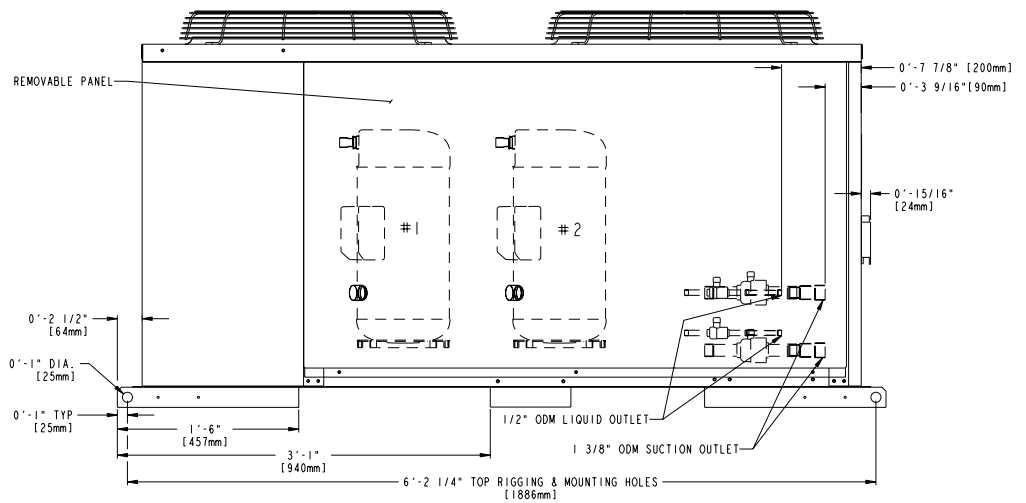

SIDE VIEW

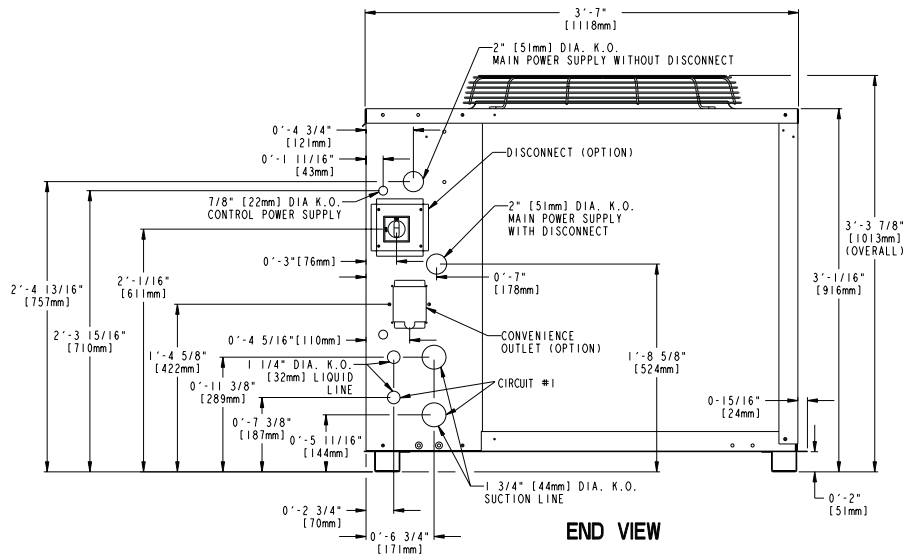

END VIEW

38ARD_AKS014-024

38ARD014-024, 38AKS014-024

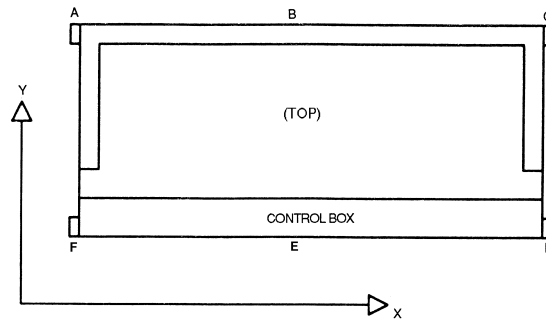

38AKS014-024

UNIT 38AKS	ALUMINUM COIL							COPPER COIL						
	Standard Weight (lb)	Operational Weight Points (lb)						Standard Weight (lb)	Operational Weight Points (lb)					
		A	B	C	D	E	F		A	B	C	D	E	F
014	779	70	177	68	100	261	103	919	99	224	96	114	268	118
016	789	70	180	69	101	265	104	929	99	228	96	115	273	118
024	900	84	234	82	108	310	111	1040	110	283	107	116	305	119

UNIT 38AKS	CENTER OF GRAVITY (in.)			
	Aluminum Coil		Copper Coil	
	X	Y	X	Y
014	38	16	38	18
016	38	16	38	18
024	37	17	37	19

38ARD014-024

UNIT 38ARD	ALUMINUM COIL							COPPER COIL						
	Standard Weight (lb)	Operational Weight Points (lb)						Standard Weight (lb)	Operational Weight Points (lb)					
		A	B	C	D	E	F		A	B	C	D	E	F
014	676	84	168	72	78	183	91	822	118	219	103	90	190	102
016	740	86	186	71	82	216	99	886	119	238	102	95	221	111
024	764	87	192	72	85	226	102	904	120	243	102	96	230	113

UNIT 38ARD	CENTER OF GRAVITY (in.)			
	Aluminum Coil		Copper Coil	
	X	Y	X	Y
014	35	19	35	21
016	35	18	35	21
024	35	18	35	20

NOTES:

1. Corner weights are approximate.
2. Actual support weights depend on level of unit and evenness of support posts.
3. Total weights represent approximate unit weights without shipping package.
4. Bottom or top skid is NOT included in the weights.

38ARD,AKS014-024

Performance data



CONDENSING UNIT RATINGS

38ARD014							
SST (F)		Air Temperature Entering Condenser (F)					
		80	85	95	100	105	115
20	TC	102.0	99.1	93.2	90.3	87.3	81.1
	kW	9.04	9.58	10.80	11.40	12.10	13.50
	SDT	103.0	108.0	118.0	123.0	128.0	138.0
25	TC	114.0	111.0	105.0	102.0	98.8	92.2
	kW	9.09	9.64	10.90	11.50	12.20	13.60
	SDT	103.0	108.0	118.0	123.0	128.0	138.0
30	TC	127.0	124.0	117.0	114.0	110.0	103.0
	kW	9.14	9.70	10.90	11.50	12.20	13.70
	SDT	103.0	108.0	118.0	123.0	128.0	138.0
35	TC	140.0	137.0	130.0	126.0	123.0	115.0
	kW	9.19	9.75	11.00	11.60	12.30	13.70
	SDT	103.0	108.0	118.0	123.0	128.0	138.0
40	TC	155.0	151.0	144.0	140.0	136.0	128.0
	kW	9.26	9.81	11.00	11.70	12.30	13.80
	SDT	103.0	108.0	118.0	123.0	128.0	138.0
45	TC	170.0	166.0	158.0	154.0	150.0	141.0
	kW	9.37	9.90	11.10	11.70	12.40	13.90
	SDT	103.0	108.0	118.0	123.0	128.0	138.0
50	TC	186.0	182.0	173.0	169.0	164.0	155.0
	kW	9.55	10.10	11.30	11.90	12.60	14.00
	SDT	104.0	109.0	119.0	124.0	129.0	139.0

38ARD024							
SST (F)		Air Temperature Entering Condenser (F)					
		80	85	95	100	105	115
20	TC	184.0	179.0	170.0	165.0	160.0	148.0
	kW	16.20	17.00	18.50	19.40	20.20	21.70
	SDT	105.0	110.0	119.0	124.0	129.0	139.0
25	TC	202.0	197.0	186.0	181.0	176.0	163.0
	kW	16.80	17.50	19.00	19.80	20.60	22.20
	SDT	107.0	112.0	121.0	126.0	131.0	140.0
30	TC	220.0	214.0	203.0	197.0	191.0	179.0
	kW	17.30	18.00	19.50	20.30	21.10	22.70
	SDT	109.0	113.0	123.0	127.0	132.0	141.0
35	TC	239.0	233.0	220.0	214.0	208.0	194.0
	kW	18.00	18.60	20.10	20.80	21.60	23.20
	SDT	111.0	116.0	125.0	129.0	134.0	143.0
40	TC	259.0	253.0	239.0	232.0	225.0	211.0
	kW	18.70	19.30	20.70	21.50	22.20	23.80
	SDT	113.0	118.0	127.0	131.0	136.0	145.0
45	TC	280.0	273.0	259.0	252.0	244.0	229.0
	kW	19.40	20.10	21.50	22.20	22.90	24.50
	SDT	116.0	120.0	129.0	134.0	138.0	147.0
50	TC	302.0	295.0	280.0	272.0	264.0	247.0
	kW	20.20	20.90	22.30	23.00	23.70	25.20
	SDT	118.0	123.0	132.0	136.0	140.0	149.0

LEGEND

- kW — Compressor Power
- SDT — Saturated Discharge Temperature at Compressor (F)
- SST — Saturated Suction Temperature (F)
- TC — Gross Cooling Capacity (1000 Btuh)

38ARD016							
SST (F)		Air Temperature Entering Condenser (F)					
		80	85	95	100	105	115
20	TC	141.0	137.0	129.0	124.0	120.0	110.0
	kW	12.01	12.60	13.70	14.30	14.90	16.10
	SDT	101.0	105.0	115.0	120.0	125.0	135.0
25	TC	156.0	152.0	143.0	138.0	133.0	123.0
	kW	12.40	12.90	14.00	14.60	15.20	16.40
	SDT	102.0	107.0	116.0	121.0	126.0	136.0
30	TC	171.0	166.0	157.0	152.0	147.0	136.0
	kW	12.70	13.20	14.30	14.90	15.50	16.70
	SDT	104.0	108.0	118.0	123.0	127.0	137.0
35	TC	187.0	182.0	172.0	166.0	161.0	150.0
	kW	13.10	13.60	14.70	15.30	15.90	17.10
	SDT	105.0	110.0	119.0	12.04	129.0	138.0
40	TC	203.0	198.0	187.0	181.0	176.0	164.0
	kW	13.50	14.00	15.10	15.70	16.30	17.50
	SDT	107.0	112.0	121.0	126.0	130.0	140.0
45	TC	221.0	215.0	204.0	198.0	192.0	179.0
	kW	13.90	14.50	15.60	16.10	16.70	17.90
	SDT	109.0	114.0	123.0	127.0	132.0	141.0
50	TC	239.0	233.0	221.0	215.0	208.0	195.0
	kW	14.40	14.90	16.10	16.70	17.20	18.40
	SDT	111.0	116.0	125.0	129.0	134.0	143.0

38ARD_AKS014-024



CONDENSING UNIT RATINGS (cont)

38AKS014							
SST (F)		Air Temperature Entering Condenser (F)					
		80	85	95	100	105	115
25	TC	101.0	97.6	90.0	86.0	82.2	74.7
	kW	8.56	8.90	9.55	9.85	10.20	10.70
	SDT	94.6	99.4	109.0	114.0	119.0	129.0
30	TC	118.0	113.0	105.0	101.0	96.7	88.5
	kW	8.80	9.17	9.90	10.20	10.60	11.20
	SDT	96.6	101.0	111.0	116.0	121.0	131.0
35	TC	134.0	129.0	120.0	116.0	111.0	102.0
	kW	9.03	9.44	10.20	10.60	11.00	11.70
	SDT	98.6	103.0	113.0	117.0	122.0	132.0
40	TC	150.0	145.0	135.0	130.0	126.0	116.0
	kW	9.26	9.71	10.60	11.00	11.40	12.20
	SDT	101.0	105.0	115.0	119.0	124.0	134.0
45	TC	166.0	161.0	150.0	145.0	140.0	130.0
	kW	9.50	9.98	10.90	11.40	11.80	12.70
	SDT	103.0	107.0	116.0	121.0	126.0	135.0
50	TC	182.0	177.0	166.0	160.0	155.0	144.0
	kW	9.73	10.30	11.30	11.70	12.20	13.10
	SDT	105.0	109.0	118.0	123.0	127.0	136.0

38AKS016							
SST (F)		Air Temperature Entering Condenser (F)					
		80	85	95	100	105	115
25	TC	139.0	134.0	126.0	121.0	117.0	108.0
	kW	12.30	12.70	13.60	14.00	14.40	15.10
	SDT	99.5	104.0	114.0	118.0	123.0	133.0
30	TC	159.0	154.0	144.0	139.0	134.0	125.0
	kW	12.90	13.40	14.30	14.70	15.20	16.00
	SDT	102.0	107.0	116.0	121.0	125.0	135.0
35	TC	179.0	173.0	163.0	157.0	152.0	142.0
	kW	13.50	14.00	15.00	15.50	16.00	16.90
	SDT	105.0	109.0	119.0	123.0	128.0	137.0
40	TC	198.0	192.0	181.0	175.0	170.0	158.0
	kW	14.00	14.60	15.70	16.30	16.80	17.80
	SDT	108.0	112.0	121.0	125.0	130.0	139.0
45	TC	218.0	212.0	199.0	193.0	187.0	175.0
	kW	14.60	15.20	16.50	17.00	17.60	18.70
	SDT	110.0	115.0	124.0	128.0	132.0	141.0
50	TC	237.0	231.0	218.0	211.0	205.0	192.0
	kW	15.20	15.90	17.20	17.80	18.40	19.60
	SDT	113.0	117.0	126.0	130.0	135.0	144.0

38AKS024							
SST (F)		Air Temperature Entering Condenser (F)					
		80	85	95	100	105	115
25	TC	175.0	169.0	157.0	151.0	145.0	134.0
	kW	16.30	16.80	17.70	18.20	18.60	19.40
	SDT	104.0	108.0	117.0	122.0	126.0	135.0
30	TC	200.0	193.0	180.0	173.0	166.0	154.0
	kW	17.20	17.80	18.80	19.30	19.80	20.70
	SDT	107.0	111.0	120.0	125.0	129.0	138.0
35	TC	224.0	217.0	202.0	195.0	188.0	175.0
	kW	18.20	18.80	19.90	20.50	21.00	22.00
	SDT	110.0	115.0	123.0	128.0	132.0	141.0
40	TC	249.0	241.0	225.0	218.0	210.0	195.0
	kW	19.10	19.80	21.00	21.60	22.20	23.30
	SDT	114.0	118.0	126.0	131.0	135.0	144.0
45	TC	273.0	265.0	248.0	240.0	232.0	216.0
	kW	20.10	20.80	22.10	22.70	23.40	24.60
	SDT	117.0	121.0	129.0	134.0	138.0	146.0
50	TC	297.0	289.0	271.0	262.0	253.0	236.0
	kW	21.00	21.80	23.20	23.90	24.60	25.90
	SDT	120.0	124.0	132.0	137.0	141.0	149.0

LEGEND

- kW — Compressor Power
- SDT — Saturated Discharge Temperature at Compressor (F)
- SST — Saturated Suction Temperature (F)
- TC — Gross Cooling Capacity (1000 Btuh)

38ARD_AKS014-024

Performance data (cont)



COMBINATION RATINGS

UNIT 38ARD014

38ARD014/40RM012H WITH HIGH-CAPACITY 4-ROW COIL

Temp (F) Air Entering Condenser (Edb)		Evaporator Air — Cfm											
		3000				4000				5000			
		Evaporator Air — Ewb (F)											
		57	62	67	72	57	62	67	72	57	62	67	72
80	TC	126.0	135.0	148.0	161.0	140.0	144.0	156.0	170.0	149.0	151.0	162.0	176.0
	SHC	126.0	112.0	95.4	78.5	140.0	130.0	109.0	87.0	149.0	146.0	122.0	94.8
	kW	9.13	9.18	9.22	9.31	9.19	9.20	9.26	9.37	9.22	9.23	9.30	9.43
85	TC	125.0	133.0	146.0	159.0	138.0	142.0	154.0	168.0	147.0	148.0	159.0	173.0
	SHC	125.0	111.0	94.5	77.5	138.0	129.0	108.0	86.0	147.0	144.0	121.0	93.8
	kW	9.68	9.72	9.79	9.87	9.74	9.77	9.82	9.92	9.78	9.80	9.85	9.98
95	TC	121.0	129.0	141.0	154.0	134.0	137.0	149.0	162.0	143.0	144.0	154.0	167.0
	SHC	121.0	109.0	92.4	75.6	134.0	127.0	106.0	84.0	143.0	141.0	118.0	91.8
	kW	10.90	11.00	11.00	11.10	11.00	11.00	11.00	11.10	11.00	11.00	11.10	11.20
100	TC	119.0	127.0	138.0	151.0	132.0	135.0	146.0	159.0	141.0	141.0	151.0	164.0
	SHC	119.0	108.0	91.4	74.6	132.0	126.0	105.0	82.9	141.0	140.0	117.0	90.7
	kW	11.60	11.60	11.70	11.70	11.60	11.60	11.70	11.80	11.60	11.70	11.70	11.80
105	TC	118.0	124.0	136.0	149.0	130.0	132.0	143.0	156.0	138.0	139.0	148.0	161.0
	SHC	118.0	107.0	90.3	73.5	130.0	124.0	104.0	81.9	138.0	138.0	116.0	89.6
	kW	12.30	12.30	12.40	12.40	12.30	12.30	12.40	12.50	12.30	12.40	12.40	12.50
115	TC	114.0	120.0	131.0	143.0	126.0	127.0	137.0	150.0	134.0	134.0	142.0	154.0
	SHC	114.0	104.0	88.0	71.4	126.0	122.0	101.0	79.6	134.0	134.0	114.0	87.4
	kW	13.70	13.80	13.80	13.90	13.80	13.80	13.80	13.90	13.80	13.80	13.90	14.00

38ARD014/40RM012 WITH STANDARD 3-ROW COIL

Temp (F) Air Entering Condenser (Edb)		Evaporator Air — Cfm											
		3000				4000				5000			
		Evaporator Air — Ewb (F)											
		57	62	67	72	57	62	67	72	57	62	67	72
80	TC	119.0	128.0	140.0	153.0	131.0	136.0	148.0	161.0	140.0	142.0	153.0	166.0
	SHC	119.0	106.0	90.4	74.3	131.0	122.0	103.0	82.0	140.0	136.0	114.0	89.0
	kW	9.09	9.15	9.18	9.23	9.15	9.16	9.21	9.30	9.19	9.19	9.25	9.33
85	TC	118.0	126.0	138.0	151.0	130.0	134.0	146.0	159.0	138.0	140.0	151.0	164.0
	SHC	118.0	105.0	89.5	73.4	130.0	121.0	102.0	81.2	138.0	135.0	113.0	88.1
	kW	9.66	9.72	9.75	9.81	9.72	9.72	9.77	9.87	9.75	9.75	9.80	9.89
95	TC	115.0	122.0	134.0	146.0	126.0	130.0	141.0	154.0	134.0	136.0	146.0	158.0
	SHC	115.0	103.0	87.7	71.7	126.0	119.0	99.9	79.3	134.0	132.0	111.0	86.3
	kW	10.90	10.90	11.00	11.00	10.90	10.90	11.00	11.10	11.00	11.00	11.00	11.10
100	TC	113.0	120.0	131.0	144.0	124.0	128.0	139.0	151.0	132.0	133.0	143.0	156.0
	SHC	113.0	102.0	86.7	70.8	124.0	118.0	98.9	78.4	132.0	131.0	110.0	85.3
	kW	11.60	11.60	11.60	11.70	11.60	11.60	11.60	11.70	11.60	11.60	11.70	11.80
105	TC	111.0	118.0	129.0	141.0	122.0	125.0	136.0	148.0	130.0	131.0	140.0	153.0
	SHC	111.0	101.0	85.7	69.8	122.0	117.0	97.9	77.5	130.0	129.0	109.0	84.3
	kW	12.20	12.30	12.30	12.40	12.30	12.30	12.30	12.40	12.30	12.30	12.40	12.40
115	TC	108.0	114.0	124.0	136.0	118.0	121.0	131.0	143.0	126.0	126.0	135.0	147.0
	SHC	108.0	99.0	83.7	67.8	118.0	114.0	95.8	75.4	126.0	126.0	107.0	82.3
	kW	13.70	13.70	13.80	13.90	13.70	13.80	13.80	13.90	13.80	13.80	13.80	13.90

LEGEND

- Edb — Entering Dry Bulb
- Ewb — Entering Wet Bulb
- kW — Compressor Motor Power Input
- SHC — Sensible Heat Capacity (1000 Btuh) Gross
- TC — Total Capacity (1000 Btuh) Gross



COMBINATION RATINGS (cont)

UNIT 38ARD014 (cont)

38ARD014/40RM014H WITH HIGH-CAPACITY 4-ROW COIL													
Temp (F) Air Entering Condenser (Edb)		Evaporator Air — Cfm											
		3750				5000				6250			
		Evaporator Air — Ewb (F)											
		57	62	67	72	57	62	67	72	57	62	67	72
80	TC	139.0	145.0	158.0	172.0	152.0	154.0	165.0	180.0	161.0	161.0	170.0	185.0
	SHC	139.0	127.0	107.0	86.2	152.0	148.0	123.0	96.1	161.0	161.0	138.0	105.0
	kW	9.18	9.21	9.27	9.38	9.25	9.24	9.33	9.48	9.29	9.31	9.37	9.54
85	TC	137.0	143.0	155.0	169.0	150.0	151.0	163.0	177.0	159.0	159.0	168.0	182.0
	SHC	137.0	126.0	106.0	85.3	150.0	146.0	122.0	95.1	159.0	159.0	137.0	104.0
	kW	9.74	9.76	9.84	9.95	9.80	9.82	9.90	10.00	9.86	9.87	9.93	10.10
95	TC	133.0	138.0	150.0	164.0	146.0	147.0	157.0	171.0	154.0	154.0	162.0	175.0
	SHC	133.0	124.0	104.0	83.3	146.0	144.0	120.0	93.1	154.0	154.0	134.0	102.0
	kW	11.00	11.00	11.10	11.20	11.00	11.00	11.10	11.20	11.10	11.10	11.10	11.30
100	TC	131.0	136.0	148.0	161.0	143.0	144.0	154.0	168.0	152.0	152.0	159.0	172.0
	SHC	131.0	123.0	103.0	82.2	143.0	142.0	119.0	92.1	152.0	152.0	133.0	101.0
	kW	11.60	11.60	11.70	11.80	11.70	11.70	11.80	11.90	11.70	11.70	11.80	11.90
105	TC	129.0	133.0	145.0	158.0	141.0	142.0	152.0	165.0	149.0	149.0	156.0	169.0
	SHC	129.0	121.0	102.0	81.1	141.0	140.0	118.0	90.9	149.0	149.0	132.0	100.0
	kW	12.30	12.30	12.40	12.50	12.40	12.40	12.50	12.60	12.40	12.40	12.50	12.60
115	TC	125.0	128.0	139.0	152.0	136.0	136.0	145.0	158.0	144.0	144.0	150.0	162.0
	SHC	125.0	119.0	99.4	78.9	136.0	136.0	115.0	88.7	144.0	144.0	129.0	97.9
	kW	13.80	13.80	13.90	14.00	13.80	13.90	13.90	14.00	13.90	13.90	13.90	14.10

38ARD014/40RM014 WITH STANDARD 3-ROW COIL													
Temp (F) Air Entering Condenser (Edb)		Evaporator Air — Cfm											
		3750				5000				6250			
		Evaporator Air — Ewb (F)											
		57	62	67	72	57	62	67	72	57	62	67	72
80	TC	130.0	137.0	150.0	163.0	143.0	145.0	157.0	171.0	151.0	151.0	162.0	176.0
	SHC	130.0	120.0	101.0	81.6	143.0	138.0	115.0	90.5	151.0	151.0	128.0	98.5
	kW	9.14	9.18	9.22	9.32	9.20	9.20	9.27	9.38	9.24	9.23	9.30	9.43
85	TC	129.0	135.0	147.0	161.0	141.0	143.0	154.0	168.0	149.0	149.0	159.0	173.0
	SHC	129.0	119.0	100.0	80.7	141.0	137.0	114.0	89.5	149.0	149.0	127.0	97.5
	kW	9.70	9.73	9.78	9.88	9.76	9.76	9.82	9.93	9.79	9.79	9.85	9.98
95	TC	125.0	131.0	143.0	156.0	137.0	138.0	149.0	162.0	145.0	145.0	154.0	167.0
	SHC	125.0	117.0	98.0	78.7	137.0	134.0	112.0	87.5	145.0	145.0	125.0	95.6
	kW	10.90	11.00	11.00	11.10	11.00	11.00	11.00	11.10	11.00	11.00	11.10	11.20
100	TC	123.0	128.0	140.0	153.0	135.0	136.0	146.0	160.0	143.0	143.0	151.0	164.0
	SHC	123.0	115.0	97.0	77.7	135.0	132.0	111.0	86.5	143.0	143.0	124.0	94.5
	kW	11.60	11.60	11.70	11.70	11.60	11.70	11.70	11.80	11.70	11.70	11.70	11.80
105	TC	122.0	126.0	137.0	150.0	132.0	133.0	144.0	157.0	140.0	140.0	148.0	161.0
	SHC	122.0	114.0	95.9	76.7	132.0	131.0	110.0	85.4	140.0	140.0	123.0	93.5
	kW	12.30	12.30	12.30	12.40	12.30	12.30	12.40	12.50	12.30	12.40	12.40	12.50
115	TC	118.0	121.0	132.0	144.0	128.0	128.0	138.0	150.0	135.0	135.0	142.0	154.0
	SHC	118.0	112.0	93.6	74.5	128.0	128.0	108.0	83.3	135.0	135.0	120.0	91.3
	kW	13.80	13.80	13.80	13.90	13.80	13.80	13.90	14.00	13.80	13.80	13.90	14.00

LEGEND

- Edb** — Entering Dry Bulb
- Ewb** — Entering Wet Bulb
- kW** — Compressor Motor Power Input
- SHC** — Sensible Heat Capacity (1000 Btuh) Gross
- TC** — Total Capacity (1000 Btuh) Gross

38ARD_AKS014-024

Performance data (cont)



COMBINATION RATINGS (cont)

UNIT 38ARD014 (cont)

38ARD014/40RM016H WITH HIGH-CAPACITY 4-ROW COIL

Temp (F) Air Entering Condenser (Edb)		Evaporator Air — Cfm											
		4500				6000				7500			
		Evaporator Air — Ewb (F)											
		57	62	67	72	57	62	67	72	57	62	67	72
80	TC	152.0	156.0	169.0	183.0	166.0	166.0	176.0	190.0	175.0	175.0	181.0	195.0
	SHC	152.0	145.0	121.0	95.4	166.0	166.0	140.0	107.0	175.0	175.0	157.0	119.0
	kW	9.24	9.26	9.35	9.53	9.33	9.33	9.43	9.63	9.42	9.43	9.49	9.69
85	TC	150.0	154.0	166.0	181.0	164.0	164.0	173.0	187.0	173.0	173.0	178.0	191.0
	SHC	150.0	144.0	120.0	94.4	164.0	164.0	139.0	106.0	173.0	173.0	156.0	118.0
	kW	9.80	9.82	9.92	10.10	9.89	9.89	9.99	10.20	9.98	9.99	10.00	10.20
95	TC	146.0	148.0	161.0	175.0	159.0	159.0	167.0	181.0	167.0	167.0	172.0	185.0
	SHC	146.0	141.0	117.0	92.2	159.0	159.0	136.0	104.0	167.0	167.0	154.0	115.0
	kW	11.00	11.10	11.10	11.30	11.10	11.10	11.20	11.40	11.20	11.20	11.20	11.40
100	TC	144.0	146.0	158.0	171.0	156.0	156.0	164.0	178.0	165.0	165.0	169.0	181.0
	SHC	144.0	140.0	116.0	91.1	156.0	156.0	135.0	103.0	165.0	165.0	152.0	114.0
	kW	11.70	11.70	11.80	11.90	11.80	11.80	11.90	12.00	11.80	11.90	11.90	12.10
105	TC	141.0	143.0	155.0	168.0	154.0	154.0	161.0	174.0	162.0	162.0	165.0	178.0
	SHC	141.0	138.0	115.0	90.0	154.0	154.0	134.0	102.0	162.0	162.0	151.0	113.0
	kW	12.40	12.40	12.50	12.60	12.50	12.50	12.50	12.70	12.50	12.50	12.60	12.80
115	TC	137.0	138.0	148.0	162.0	148.0	148.0	154.0	167.0	156.0	156.0	159.0	170.0
	SHC	137.0	135.0	112.0	87.6	148.0	148.0	131.0	99.5	156.0	156.0	148.0	111.0
	kW	13.90	13.90	13.90	14.10	13.90	14.00	14.00	14.20	14.00	14.00	14.00	14.20

38ARD014/40RM016 WITH STANDARD 3-ROW COIL

Temp (F) Air Entering Condenser (Edb)		Evaporator Air — Cfm											
		4500				6000				7500			
		Evaporator Air — Ewb (F)											
		57	62	67	72	57	62	67	72	57	62	67	72
80	TC	143.0	147.0	160.0	174.0	155.0	156.0	166.0	180.0	164.0	164.0	171.0	185.0
	SHC	143.0	136.0	113.0	89.9	155.0	155.0	130.0	100.0	164.0	164.0	146.0	110.0
	kW	9.19	9.22	9.28	9.42	9.27	9.26	9.34	9.49	9.31	9.33	9.37	9.54
85	TC	141.0	145.0	157.0	171.0	153.0	153.0	164.0	178.0	162.0	162.0	168.0	182.0
	SHC	141.0	134.0	112.0	89.0	153.0	153.0	129.0	99.5	162.0	162.0	144.0	109.0
	kW	9.75	9.77	9.85	9.98	9.82	9.82	9.90	10.00	9.87	9.89	9.93	10.10
95	TC	137.0	140.0	152.0	165.0	149.0	149.0	158.0	172.0	157.0	157.0	162.0	175.0
	SHC	137.0	132.0	110.0	86.9	149.0	149.0	127.0	97.4	157.0	157.0	142.0	107.0
	kW	11.00	11.00	11.10	11.20	11.00	11.00	11.10	11.20	11.10	11.10	11.10	11.30
100	TC	135.0	138.0	149.0	162.0	146.0	146.0	155.0	168.0	154.0	154.0	159.0	172.0
	SHC	135.0	131.0	109.0	85.8	146.0	146.0	126.0	96.3	154.0	154.0	141.0	106.0
	kW	11.60	11.60	11.70	11.80	11.70	11.70	11.80	11.90	11.70	11.80	11.80	11.90
105	TC	133.0	135.0	146.0	159.0	144.0	144.0	152.0	165.0	152.0	152.0	156.0	169.0
	SHC	133.0	129.0	108.0	84.7	144.0	144.0	125.0	95.2	152.0	152.0	139.0	105.0
	kW	12.30	12.30	12.40	12.50	12.40	12.40	12.50	12.60	12.40	12.50	12.50	12.60
115	TC	129.0	130.0	140.0	153.0	139.0	139.0	146.0	158.0	146.0	146.0	150.0	162.0
	SHC	129.0	126.0	106.0	82.5	139.0	139.0	122.0	92.9	146.0	146.0	137.0	103.0
	kW	13.80	13.80	13.90	14.00	13.90	13.90	13.90	14.10	13.90	13.90	13.90	14.10

LEGEND

- Edb — Entering Dry Bulb
- Ewb — Entering Wet Bulb
- kW — Compressor Motor Power Input
- SHC — Sensible Heat Capacity (1000 Btuh) Gross
- TC — Total Capacity (1000 Btuh) Gross



COMBINATION RATINGS (cont)

UNIT 38ARD016

38ARD016/40RM014H WITH HIGH-CAPACITY 4-ROW COIL

Temp (F) Air Entering Condenser (Edb)		Evaporator Air — Cfm											
		3750				5000				6250			
		Evaporator Air — Ewb (F)											
		57	62	67	72	57	62	67	72	57	62	67	72
80	TC	163.0	175.0	190.0	206.0	179.0	186.0	201.0	217.0	191.0	194.0	208.0	224.0
	SHC	161.0	142.0	121.0	99.8	179.0	164.0	138.0	110.0	191.0	184.0	153.0	119.0
	kW	12.60	12.80	13.20	13.60	12.90	13.10	13.40	13.80	13.20	13.30	13.60	14.00
85	TC	160.0	172.0	187.0	203.0	176.0	183.0	198.0	214.0	188.0	190.0	204.0	220.0
	SHC	159.0	141.0	120.0	98.5	176.0	163.0	136.0	109.0	188.0	182.0	151.0	118.0
	kW	13.10	13.40	13.80	14.20	13.50	13.70	14.00	14.40	13.80	13.80	14.20	14.60
95	TC	155.0	166.0	180.0	196.0	170.0	176.0	190.0	206.0	181.0	183.0	196.0	212.0
	SHC	155.0	138.0	117.0	95.6	170.0	159.0	133.0	106.0	181.0	178.0	148.0	115.0
	kW	14.30	14.60	15.00	15.40	14.70	14.80	15.20	15.70	15.00	15.00	15.40	15.80
100	TC	152.0	163.0	177.0	192.0	167.0	172.0	186.0	201.0	178.0	180.0	192.0	208.0
	SHC	152.0	136.0	115.0	94.0	167.0	158.0	131.0	104.0	178.0	176.0	146.0	113.0
	kW	14.90	15.20	15.60	16.00	15.30	15.50	15.80	16.30	15.60	15.60	16.00	16.50
105	TC	150.0	159.0	173.0	188.0	164.0	168.0	182.0	197.0	175.0	176.0	188.0	203.0
	SHC	150.0	134.0	114.0	92.4	164.0	156.0	130.0	102.0	175.0	173.0	145.0	112.0
	kW	15.60	15.80	16.20	16.60	16.00	16.10	16.50	16.90	16.30	16.30	16.60	17.10
115	TC	144.0	152.0	165.0	179.0	158.0	161.0	173.0	188.0	168.0	168.0	178.0	193.0
	SHC	144.0	131.0	110.0	89.1	158.0	152.0	126.0	99.0	168.0	167.0	141.0	108.0
	kW	16.90	17.10	17.50	18.00	17.30	17.40	17.80	18.20	17.60	17.60	17.90	18.40

38ARD016/40RM014 WITH STANDARD 3-ROW COIL

Temp (F) Air Entering Condenser (Edb)		Evaporator Air — Cfm											
		3750				5000				6250			
		Evaporator Air — Ewb (F)											
		57	62	67	72	57	62	67	72	57	62	67	72
80	TC	154.0	166.0	181.0	196.0	168.0	176.0	191.0	206.0	179.0	183.0	197.0	213.0
	SHC	152.0	134.0	115.0	94.7	168.0	154.0	129.0	104.0	179.0	171.0	143.0	112.0
	kW	12.40	12.60	13.00	13.30	12.70	12.90	13.20	13.60	12.90	13.00	13.40	13.70
85	TC	152.0	163.0	178.0	193.0	166.0	173.0	188.0	203.0	176.0	180.0	194.0	210.0
	SHC	150.0	133.0	113.0	93.4	166.0	153.0	128.0	102.0	176.0	169.0	141.0	111.0
	kW	12.90	13.20	13.50	13.90	13.20	13.40	13.80	14.20	13.50	13.60	13.90	14.30
95	TC	147.0	157.0	171.0	186.0	160.0	167.0	180.0	196.0	171.0	173.0	187.0	202.0
	SHC	146.0	130.0	111.0	90.6	160.0	149.0	125.0	99.7	171.0	166.0	138.0	108.0
	kW	14.10	14.40	14.70	15.10	14.40	14.60	15.00	15.40	14.70	14.80	15.10	15.50
100	TC	144.0	154.0	168.0	182.0	158.0	163.0	177.0	191.0	167.0	170.0	182.0	197.0
	SHC	144.0	128.0	109.0	89.1	158.0	148.0	123.0	98.1	167.0	163.0	137.0	106.0
	kW	14.80	15.00	15.30	15.70	15.10	15.20	15.60	16.00	15.30	15.40	15.70	16.20
105	TC	141.0	151.0	164.0	179.0	155.0	160.0	173.0	187.0	164.0	166.0	178.0	193.0
	SHC	141.0	127.0	107.0	87.6	155.0	146.0	122.0	96.5	164.0	161.0	135.0	105.0
	kW	15.40	15.60	16.00	16.40	15.70	15.80	16.20	16.60	16.00	16.00	16.40	16.80
115	TC	136.0	144.0	157.0	170.0	149.0	152.0	165.0	178.0	158.0	159.0	170.0	183.0
	SHC	136.0	124.0	104.0	84.4	149.0	142.0	118.0	93.3	158.0	156.0	132.0	101.0
	kW	16.80	16.90	17.30	17.70	17.10	17.20	17.50	17.90	17.30	17.30	17.70	18.10

LEGEND

- Edb — Entering Dry Bulb
- Ewb — Entering Wet Bulb
- kW — Compressor Motor Power Input
- SHC — Sensible Heat Capacity (1000 Btuh) Gross
- TC — Total Capacity (1000 Btuh) Gross

38ARD_AKS014-024

Performance data (cont)



COMBINATION RATINGS (cont)

UNIT 38ARD016 (cont)

38ARD016/40RM016H WITH HIGH-CAPACITY 4-ROW COIL

Temp (F) Air Entering Condenser (Edb)		Evaporator Air — Cfm											
		4500				6000				7500			
		Evaporator Air — Ewb (F)											
		57	62	67	72	57	62	67	72	57	62	67	72
80	TC	180.0	190.0	206.0	223.0	197.0	201.0	216.0	233.0	209.0	210.0	222.0	239.0
	SHC	180.0	162.0	136.0	110.0	197.0	188.0	156.0	122.0	209.0	208.0	174.0	134.0
	kW	12.90	13.20	13.60	14.00	13.30	13.40	13.80	14.20	13.60	13.70	14.00	14.40
85	TC	177.0	187.0	203.0	220.0	194.0	198.0	212.0	229.0	206.0	206.0	219.0	235.0
	SHC	177.0	160.0	135.0	109.0	194.0	186.0	154.0	121.0	206.0	206.0	173.0	132.0
	kW	13.50	13.80	14.20	14.60	13.90	14.00	14.40	14.80	14.20	14.20	14.60	15.00
95	TC	172.0	180.0	195.0	212.0	188.0	190.0	204.0	221.0	199.0	199.0	210.0	226.0
	SHC	172.0	157.0	132.0	106.0	188.0	182.0	151.0	118.0	199.0	199.0	169.0	129.0
	kW	14.70	14.90	15.40	15.80	15.20	15.20	15.60	16.10	15.50	15.50	15.80	16.20
100	TC	169.0	176.0	191.0	207.0	184.0	186.0	200.0	216.0	195.0	195.0	205.0	221.0
	SHC	169.0	155.0	130.0	104.0	184.0	180.0	149.0	116.0	195.0	195.0	168.0	128.0
	kW	15.40	15.60	16.00	16.40	15.80	15.80	16.20	16.70	16.10	16.10	16.40	16.90
105	TC	166.0	172.0	187.0	203.0	181.0	182.0	195.0	211.0	191.0	191.0	201.0	216.0
	SHC	166.0	153.0	128.0	102.0	181.0	178.0	147.0	115.0	191.0	191.0	166.0	126.0
	kW	16.00	16.20	16.60	17.10	16.40	16.50	16.90	17.40	16.70	16.80	17.00	17.50
115	TC	159.0	164.0	178.0	193.0	173.0	174.0	185.0	201.0	183.0	183.0	191.0	205.0
	SHC	159.0	149.0	124.0	98.8	173.0	172.0	144.0	111.0	183.0	183.0	162.0	122.0
	kW	17.30	17.50	17.90	18.40	17.80	17.80	18.10	18.60	18.10	18.10	18.30	18.80

38ARD016/40RM016 WITH STANDARD 3-ROW COIL

Temp (F) Air Entering Condenser (Edb)		Evaporator Air — Cfm											
		4500				6000				7500			
		Evaporator Air — Ewb (F)											
		57	62	67	72	57	62	67	72	57	62	67	72
80	TC	169.0	180.0	195.0	211.0	185.0	190.0	204.0	221.0	196.0	197.0	211.0	227.0
	SHC	169.0	152.0	128.0	104.0	185.0	175.0	146.0	115.0	196.0	193.0	162.0	125.0
	kW	12.70	12.90	13.30	13.70	13.10	13.20	13.50	13.90	13.30	13.30	13.70	14.10
85	TC	167.0	177.0	192.0	208.0	182.0	186.0	201.0	217.0	193.0	194.0	207.0	223.0
	SHC	167.0	151.0	127.0	103.0	182.0	173.0	144.0	113.0	193.0	191.0	160.0	123.0
	kW	13.30	13.50	13.90	14.30	13.60	13.70	14.10	14.50	13.90	13.90	14.30	14.70
95	TC	161.0	170.0	184.0	200.0	176.0	179.0	193.0	209.0	186.0	187.0	199.0	215.0
	SHC	161.0	147.0	124.0	99.8	176.0	169.0	141.0	111.0	186.0	186.0	157.0	120.0
	kW	14.50	14.70	15.10	15.50	14.80	14.90	15.30	15.70	15.10	15.10	15.50	15.90
100	TC	159.0	166.0	181.0	196.0	173.0	176.0	189.0	204.0	183.0	183.0	194.0	210.0
	SHC	159.0	145.0	122.0	98.2	173.0	167.0	139.0	109.0	183.0	183.0	155.0	119.0
	kW	15.10	15.30	15.70	16.10	15.50	15.50	15.90	16.40	15.70	15.70	16.10	16.50
105	TC	156.0	163.0	177.0	192.0	169.0	172.0	185.0	200.0	179.0	179.0	190.0	205.0
	SHC	156.0	144.0	120.0	96.6	169.0	165.0	138.0	107.0	179.0	179.0	153.0	117.0
	kW	15.70	15.90	16.30	16.80	16.10	16.20	16.50	17.00	16.40	16.40	16.70	17.20
115	TC	150.0	155.0	168.0	183.0	163.0	164.0	175.0	190.0	172.0	172.0	180.0	195.0
	SHC	150.0	140.0	117.0	93.2	163.0	160.0	134.0	104.0	172.0	172.0	150.0	114.0
	kW	17.10	17.20	17.60	18.10	17.50	17.50	17.80	18.30	17.70	17.70	18.00	18.50

LEGEND

- Edb — Entering Dry Bulb
- Ewb — Entering Wet Bulb
- kW — Compressor Motor Power Input
- SHC — Sensible Heat Capacity (1000 Btuh) Gross
- TC — Total Capacity (1000 Btuh) Gross



COMBINATION RATINGS (cont)

UNIT 38ARD016 (cont)

38ARD016/40RM024H WITH HIGH-CAPACITY 4-ROW COIL

Temp (F) Air Entering Condenser (Edb)		Evaporator Air — Cfm											
		6,000				8,000				10,000			
		Evaporator Air — Ewb (F)											
		57	62	67	72	57	62	67	72	57	62	67	72
80	TC	201.0	205.0	220.0	238.0	217.0	217.0	229.0	246.0	228.0	228.0	234.0	251.0
	SHC	201.0	191.0	159.0	125.0	217.0	217.0	184.0	140.0	228.0	228.0	207.0	155.0
	kW	13.40	13.50	13.90	14.40	13.80	13.80	14.10	14.60	14.10	14.10	14.30	14.70
85	TC	198.0	202.0	216.0	234.0	214.0	214.0	225.0	242.0	225.0	225.0	230.0	247.0
	SHC	198.0	190.0	157.0	123.0	214.0	214.0	182.0	139.0	225.0	225.0	205.0	154.0
	kW	14.00	14.10	14.50	15.00	14.40	14.40	14.70	15.20	14.70	14.70	14.90	15.30
95	TC	191.0	194.0	208.0	225.0	207.0	207.0	216.0	232.0	217.0	217.0	221.0	237.0
	SHC	191.0	186.0	154.0	120.0	207.0	207.0	179.0	136.0	217.0	217.0	201.0	150.0
	kW	15.30	15.30	15.70	16.20	15.70	15.70	15.90	16.40	16.00	16.00	16.10	16.60
100	TC	188.0	190.0	204.0	220.0	202.0	203.0	211.0	227.0	213.0	213.0	216.0	232.0
	SHC	188.0	183.0	152.0	118.0	202.0	203.0	177.0	134.0	213.0	213.0	199.0	149.0
	kW	15.90	15.90	16.30	16.80	16.30	16.30	16.60	17.10	16.60	16.60	16.70	17.20
105	TC	184.0	185.0	199.0	215.0	198.0	198.0	206.0	222.0	208.0	208.0	211.0	226.0
	SHC	184.0	181.0	150.0	117.0	198.0	198.0	175.0	132.0	208.0	208.0	197.0	147.0
	kW	16.50	16.60	17.00	17.50	17.00	17.00	17.20	17.70	17.30	17.30	17.40	17.80
115	TC	176.0	177.0	189.0	205.0	190.0	190.0	196.0	211.0	199.0	199.0	201.0	214.0
	SHC	176.0	176.0	146.0	113.0	190.0	190.0	171.0	128.0	199.0	199.0	192.0	143.0
	kW	17.90	17.90	18.30	18.80	18.30	18.30	18.50	19.00	18.60	18.60	18.70	19.10

38ARD016/40RM024 WITH STANDARD 3-ROW COIL

Temp (F) Air Entering Condenser (Edb)		Evaporator Air — Cfm											
		6,000				8,000				10,000			
		Evaporator Air — Ewb (F)											
		57	62	67	72	57	62	67	72	57	62	67	72
80	TC	190.0	194.0	209.0	226.0	205.0	205.0	217.0	233.0	215.0	215.0	222.0	238.0
	SHC	190.0	181.0	150.0	118.0	205.0	204.0	173.0	132.0	215.0	215.0	193.0	145.0
	kW	13.20	13.30	13.60	14.00	13.50	13.50	13.80	14.20	13.80	13.80	14.00	14.40
85	TC	187.0	191.0	205.0	222.0	202.0	202.0	213.0	229.0	211.0	211.0	218.0	234.0
	SHC	187.0	179.0	149.0	117.0	202.0	201.0	171.0	131.0	211.0	211.0	191.0	144.0
	kW	13.80	13.90	14.20	14.60	14.10	14.10	14.40	14.80	14.40	14.40	14.50	15.00
95	TC	181.0	184.0	197.0	213.0	195.0	195.0	204.0	220.0	204.0	204.0	209.0	225.0
	SHC	181.0	175.0	146.0	114.0	195.0	195.0	168.0	128.0	204.0	204.0	187.0	141.0
	kW	15.00	15.00	15.40	15.90	15.30	15.30	15.60	16.10	15.60	15.60	15.80	16.20
100	TC	178.0	180.0	193.0	209.0	191.0	191.0	200.0	216.0	200.0	200.0	205.0	220.0
	SHC	178.0	173.0	144.0	112.0	191.0	191.0	166.0	126.0	200.0	200.0	185.0	139.0
	kW	15.60	15.70	16.00	16.50	16.00	16.00	16.20	16.70	16.20	16.20	16.40	16.80
105	TC	174.0	176.0	188.0	204.0	187.0	187.0	195.0	210.0	196.0	196.0	200.0	215.0
	SHC	174.0	171.0	142.0	110.0	187.0	187.0	164.0	124.0	196.0	196.0	183.0	137.0
	kW	16.20	16.30	16.60	17.10	16.60	16.60	16.90	17.30	16.90	16.90	17.00	17.50
115	TC	167.0	168.0	179.0	194.0	179.0	179.0	185.0	200.0	187.0	187.0	190.0	203.0
	SHC	167.0	166.0	138.0	107.0	179.0	179.0	160.0	121.0	187.0	187.0	178.0	133.0
	kW	17.60	17.60	18.00	18.40	17.90	17.90	18.10	18.60	18.20	18.20	18.30	18.70

LEGEND

- Edb — Entering Dry Bulb
- Ewb — Entering Wet Bulb
- kW — Compressor Motor Power Input
- SHC — Sensible Heat Capacity (1000 Btuh) Gross
- TC — Total Capacity (1000 Btuh) Gross

38ARD_AKS014-024

Performance data (cont)



COMBINATION RATINGS (cont)

UNIT 38ARD024

38ARD024/40RM016H WITH HIGH-CAPACITY 4-ROW COIL

Temp (F) Air Entering Condenser (Edb)		Evaporator Air — Cfm											
		4500				6000				7500			
		Evaporator Air — Ewb (F)											
		57	62	67	72	57	62	67	72	57	62	67	72
80	TC	198.0	213.0	231.0	250.0	216.0	226.0	244.0	263.0	230.0	235.0	252.0	272.0
	SHC	193.0	170.0	146.0	120.0	216.0	196.0	164.0	132.0	230.0	218.0	181.0	142.0
	kW	16.70	17.20	17.70	18.40	17.20	17.60	18.20	18.80	17.70	17.90	18.50	19.10
85	TC	195.0	210.0	228.0	246.0	213.0	222.0	240.0	259.0	226.0	231.0	248.0	267.0
	SHC	191.0	169.0	144.0	119.0	213.0	194.0	162.0	130.0	226.0	216.0	179.0	140.0
	kW	17.50	17.90	18.50	19.10	18.00	18.30	18.90	19.60	18.40	18.60	19.20	19.90
95	TC	189.0	203.0	220.0	238.0	206.0	215.0	231.0	250.0	219.0	223.0	239.0	257.0
	SHC	187.0	165.0	140.0	115.0	206.0	190.0	159.0	126.0	219.0	211.0	176.0	137.0
	kW	19.10	19.50	20.10	20.70	19.60	19.90	20.50	21.20	20.00	20.20	20.80	21.50
100	TC	186.0	199.0	216.0	233.0	203.0	211.0	227.0	245.0	215.0	219.0	234.0	252.0
	SHC	185.0	163.0	139.0	113.0	203.0	188.0	157.0	125.0	215.0	209.0	174.0	135.0
	kW	20.00	20.40	20.90	21.50	20.50	20.70	21.30	22.00	20.90	21.00	21.60	22.30
105	TC	183.0	195.0	211.0	229.0	199.0	206.0	222.0	240.0	212.0	214.0	229.0	247.0
	SHC	182.0	161.0	137.0	112.0	199.0	186.0	155.0	123.0	212.0	206.0	172.0	133.0
	kW	20.90	21.20	21.80	22.40	21.30	21.60	22.10	22.80	21.80	21.80	22.40	23.10
115	TC	176.0	187.0	203.0	219.0	192.0	197.0	212.0	229.0	204.0	205.0	219.0	235.0
	SHC	176.0	157.0	133.0	108.0	192.0	181.0	151.0	119.0	204.0	201.0	167.0	129.0
	kW	22.70	23.00	23.50	24.10	23.20	23.30	23.90	24.50	23.60	23.60	24.10	24.80

38ARD024/40RM016 WITH STANDARD 3-ROW COIL

Temp (F) Air Entering Condenser (Edb)		Evaporator Air — Cfm											
		4500				6000				7500			
		Evaporator Air — Ewb (F)											
		57	62	67	72	57	62	67	72	57	62	67	72
80	TC	196.0	211.0	229.0	248.0	212.0	224.0	242.0	261.0	226.0	233.0	250.0	270.0
	SHC	190.0	168.0	144.0	119.0	212.0	192.0	161.0	130.0	226.0	213.0	178.0	140.0
	kW	16.70	17.10	17.70	18.30	17.10	17.50	18.10	18.80	17.60	17.80	18.40	19.10
85	TC	193.0	207.0	225.0	244.0	209.0	220.0	238.0	257.0	223.0	229.0	246.0	265.0
	SHC	188.0	166.0	142.0	117.0	209.0	190.0	160.0	128.0	223.0	211.0	176.0	138.0
	kW	17.40	17.80	18.40	19.00	17.90	18.20	18.80	19.50	18.30	18.50	19.10	19.80
95	TC	187.0	200.0	217.0	235.0	203.0	212.0	229.0	247.0	216.0	220.0	236.0	255.0
	SHC	184.0	162.0	138.0	114.0	203.0	186.0	156.0	125.0	216.0	207.0	172.0	135.0
	kW	19.00	19.40	20.00	20.60	19.50	19.80	20.40	21.10	19.90	20.10	20.70	21.40
100	TC	184.0	197.0	213.0	231.0	200.0	208.0	224.0	242.0	212.0	216.0	231.0	249.0
	SHC	182.0	161.0	136.0	112.0	200.0	184.0	154.0	123.0	212.0	204.0	170.0	133.0
	kW	19.90	20.30	20.80	21.40	20.40	20.60	21.20	21.90	20.80	20.90	21.50	22.20
105	TC	180.0	193.0	209.0	226.0	196.0	204.0	220.0	237.0	208.0	211.0	226.0	244.0
	SHC	179.0	159.0	135.0	110.0	196.0	182.0	152.0	121.0	208.0	202.0	168.0	131.0
	kW	20.80	21.10	21.70	22.30	21.20	21.50	22.00	22.70	21.60	21.70	22.30	23.00
115	TC	173.0	185.0	200.0	216.0	189.0	195.0	210.0	226.0	200.0	202.0	216.0	233.0
	SHC	173.0	155.0	131.0	106.0	189.0	178.0	148.0	117.0	200.0	197.0	164.0	127.0
	kW	22.60	22.90	23.50	24.00	23.10	23.30	23.80	24.40	23.50	23.50	24.00	24.70

LEGEND

- Edb — Entering Dry Bulb
- Ewb — Entering Wet Bulb
- kW — Compressor Motor Power Input
- SHC — Sensible Heat Capacity (1000 Btuh) Gross
- TC — Total Capacity (1000 Btuh) Gross

38ARD_AKS014-024



COMBINATION RATINGS (cont)

UNIT 38ARD024 (cont)

38ARD024/40RM024H WITH HIGH-CAPACITY 4-ROW COIL													
Temp (F) Air Entering Condenser (Edb)		Evaporator Air — Cfm											
		6,000				8,000				10,000			
		Evaporator Air — Ewb (F)											
		57	62	67	72	57	62	67	72	57	62	67	72
80	TC	228.0	239.0	258.0	279.0	248.0	252.0	269.0	290.0	262.0	262.0	277.0	297.0
	SHC	228.0	207.0	174.0	139.0	248.0	240.0	199.0	155.0	262.0	262.0	222.0	169.0
	kW	17.60	18.00	18.70	19.40	18.30	18.40	19.10	19.80	18.80	18.80	19.30	20.10
85	TC	225.0	235.0	254.0	274.0	245.0	248.0	265.0	285.0	258.0	258.0	272.0	291.0
	SHC	225.0	205.0	172.0	137.0	245.0	237.0	197.0	153.0	258.0	258.0	220.0	167.0
	kW	18.40	18.70	19.40	20.10	19.10	19.20	19.80	20.60	19.60	19.60	20.10	20.80
95	TC	218.0	227.0	244.0	263.0	236.0	238.0	254.0	274.0	249.0	249.0	261.0	280.0
	SHC	218.0	201.0	168.0	134.0	236.0	232.0	193.0	149.0	249.0	249.0	216.0	163.0
	kW	20.00	20.30	21.00	21.70	20.70	20.70	21.30	22.10	21.10	21.10	21.60	22.40
100	TC	214.0	222.0	239.0	258.0	232.0	234.0	249.0	268.0	245.0	245.0	255.0	274.0
	SHC	214.0	199.0	166.0	132.0	232.0	229.0	190.0	147.0	245.0	245.0	213.0	161.0
	kW	20.90	21.10	21.70	22.50	21.50	21.50	22.10	22.90	22.00	22.00	22.40	23.10
105	TC	211.0	217.0	234.0	252.0	228.0	229.0	243.0	262.0	240.0	240.0	249.0	267.0
	SHC	211.0	196.0	163.0	130.0	228.0	226.0	188.0	145.0	240.0	240.0	211.0	159.0
	kW	21.70	22.00	22.60	23.30	22.40	22.40	22.90	23.70	22.80	22.80	23.20	23.90
115	TC	203.0	207.0	223.0	241.0	219.0	219.0	231.0	249.0	230.0	230.0	237.0	254.0
	SHC	203.0	192.0	159.0	125.0	219.0	219.0	184.0	140.0	230.0	230.0	206.0	155.0
	kW	23.50	23.70	24.30	25.00	24.10	24.10	24.60	25.40	24.60	24.60	24.90	25.60

38ARD024/40RM024 WITH STANDARD 3-ROW COIL													
Temp (F) Air Entering Condenser (Edb)		Evaporator Air — Cfm											
		6,000				8,000				10,000			
		Evaporator Air — Ewb (F)											
		57	62	67	72	57	62	67	72	57	62	67	72
80	TC	219.0	229.0	248.0	267.0	237.0	241.0	259.0	278.0	250.0	251.0	265.0	285.0
	SHC	219.0	199.0	167.0	134.0	237.0	228.0	190.0	148.0	250.0	250.0	211.0	161.0
	kW	17.30	17.70	18.30	19.00	17.90	18.10	18.70	19.40	18.40	18.40	18.90	19.60
85	TC	216.0	226.0	243.0	263.0	234.0	237.0	254.0	273.0	246.0	247.0	261.0	280.0
	SHC	216.0	197.0	165.0	132.0	234.0	226.0	188.0	146.0	246.0	246.0	209.0	159.0
	kW	18.10	18.40	19.00	19.70	18.70	18.80	19.40	20.10	19.10	19.10	19.70	20.40
95	TC	209.0	217.0	234.0	253.0	226.0	228.0	244.0	263.0	238.0	238.0	250.0	269.0
	SHC	209.0	192.0	161.0	128.0	226.0	221.0	184.0	142.0	238.0	238.0	205.0	155.0
	kW	19.70	20.00	20.60	21.30	20.30	20.40	20.90	21.70	20.70	20.70	21.20	21.90
100	TC	206.0	213.0	230.0	248.0	222.0	224.0	239.0	257.0	234.0	234.0	245.0	263.0
	SHC	206.0	190.0	159.0	126.0	222.0	218.0	182.0	140.0	234.0	234.0	202.0	153.0
	kW	20.60	20.80	21.40	22.10	21.10	21.20	21.70	22.50	21.50	21.50	22.00	22.70
105	TC	202.0	209.0	225.0	242.0	218.0	219.0	233.0	251.0	229.0	229.0	239.0	257.0
	SHC	202.0	188.0	157.0	124.0	218.0	215.0	180.0	138.0	229.0	229.0	200.0	151.0
	kW	21.40	21.70	22.20	22.90	22.00	22.00	22.60	23.30	22.40	22.40	22.80	23.50
115	TC	195.0	200.0	215.0	232.0	210.0	210.0	223.0	239.0	220.0	220.0	228.0	244.0
	SHC	195.0	184.0	153.0	120.0	210.0	209.0	175.0	134.0	220.0	220.0	196.0	147.0
	kW	23.30	23.40	24.00	24.60	23.80	23.80	24.30	25.00	24.20	24.20	24.50	25.20

LEGEND

- Edb — Entering Dry Bulb
- Ewb — Entering Wet Bulb
- kW — Compressor Motor Power Input
- SHC — Sensible Heat Capacity (1000 Btuh) Gross
- TC — Total Capacity (1000 Btuh) Gross

38ARD_AKS014-024

Performance data (cont)



COMBINATION RATINGS (cont)

UNIT 38ARD024 (cont)

38ARD024/40RM028H WITH HIGH-CAPACITY 4-ROW COIL

Temp (F) Air Entering Condenser (Edb)		Evaporator Air — Cfm											
		7,500				10,000				12,500			
		Evaporator Air — Ewb (F)											
		57	62	67	72	57	62	67	72	57	62	67	72
80	TC	249.0	254.0	272.0	293.0	268.0	268.0	282.0	303.0	281.0	281.0	289.0	309.0
	SHC	249.0	236.0	196.0	154.0	268.0	268.0	226.0	172.0	281.0	281.0	253.0	190.0
	kW	18.30	18.50	19.20	19.90	19.00	19.00	19.50	20.30	19.50	19.50	19.80	20.50
85	TC	245.0	249.0	267.0	288.0	263.0	263.0	277.0	297.0	276.0	276.0	283.0	303.0
	SHC	245.0	234.0	194.0	152.0	263.0	263.0	224.0	170.0	276.0	276.0	251.0	188.0
	kW	19.10	19.20	19.90	20.70	19.80	19.80	20.30	21.00	20.20	20.20	20.50	21.30
95	TC	237.0	240.0	257.0	277.0	254.0	254.0	266.0	285.0	266.0	266.0	272.0	290.0
	SHC	237.0	229.0	190.0	148.0	254.0	254.0	220.0	166.0	266.0	266.0	246.0	184.0
	kW	20.70	20.80	21.40	22.20	21.30	21.30	21.80	22.60	21.80	21.80	22.00	22.80
100	TC	232.0	235.0	251.0	271.0	249.0	250.0	260.0	279.0	261.0	261.0	266.0	284.0
	SHC	232.0	226.0	187.0	145.0	249.0	250.0	217.0	164.0	261.0	261.0	244.0	182.0
	kW	21.50	21.60	22.20	23.00	22.20	22.10	22.60	23.40	22.60	22.60	22.80	23.60
105	TC	228.0	230.0	246.0	265.0	244.0	245.0	254.0	272.0	256.0	256.0	260.0	277.0
	SHC	228.0	223.0	185.0	143.0	244.0	245.0	215.0	162.0	256.0	256.0	241.0	180.0
	kW	22.30	22.40	23.00	23.80	23.00	23.00	23.40	24.20	23.50	23.40	23.60	24.40
115	TC	219.0	219.0	234.0	252.0	234.0	234.0	241.0	259.0	244.0	244.0	247.0	263.0
	SHC	219.0	217.0	180.0	139.0	234.0	234.0	210.0	157.0	244.0	244.0	235.0	175.0
	kW	24.10	24.10	24.70	25.50	24.70	24.70	25.00	25.80	25.20	25.20	25.30	26.00

38ARD024/40RM028 WITH STANDARD 3-ROW COIL

Temp (F) Air Entering Condenser (Edb)		Evaporator Air — Cfm											
		7,500				10,000				12,500			
		Evaporator Air — Ewb (F)											
		57	62	67	72	57	62	67	72	57	62	67	72
80	TC	236.0	242.0	260.0	280.0	254.0	254.0	269.0	290.0	266.0	266.0	276.0	296.0
	SHC	236.0	223.0	185.0	146.0	254.0	252.0	212.0	162.0	266.0	266.0	236.0	178.0
	kW	17.90	18.10	18.70	19.50	18.50	18.50	19.10	19.80	18.90	18.90	19.30	20.00
85	TC	233.0	238.0	256.0	275.0	250.0	250.0	265.0	285.0	262.0	262.0	271.0	290.0
	SHC	233.0	221.0	184.0	144.0	250.0	249.0	210.0	161.0	262.0	262.0	234.0	176.0
	kW	18.70	18.80	19.50	20.20	19.30	19.30	19.80	20.60	19.70	19.70	20.00	20.80
95	TC	225.0	229.0	246.0	265.0	242.0	242.0	255.0	273.0	253.0	253.0	260.0	279.0
	SHC	225.0	216.0	179.0	140.0	242.0	242.0	206.0	157.0	253.0	253.0	230.0	172.0
	kW	20.30	20.40	21.00	21.80	20.90	20.90	21.40	22.10	21.30	21.30	21.60	22.30
100	TC	221.0	225.0	241.0	260.0	237.0	237.0	249.0	268.0	248.0	248.0	255.0	273.0
	SHC	221.0	214.0	178.0	138.0	237.0	237.0	204.0	155.0	248.0	248.0	227.0	170.0
	kW	21.10	21.20	21.80	22.50	21.70	21.70	22.10	22.90	22.10	22.10	22.40	23.10
105	TC	217.0	220.0	236.0	254.0	233.0	233.0	243.0	262.0	243.0	243.0	249.0	266.0
	SHC	217.0	211.0	175.0	136.0	233.0	233.0	202.0	153.0	243.0	243.0	225.0	168.0
	kW	22.00	22.10	22.60	23.40	22.50	22.50	23.00	23.70	22.90	22.90	23.20	23.90
115	TC	209.0	211.0	225.0	242.0	223.0	223.0	232.0	249.0	233.0	233.0	237.0	253.0
	SHC	209.0	206.0	171.0	132.0	223.0	223.0	197.0	148.0	233.0	233.0	219.0	164.0
	kW	23.80	23.80	24.40	25.10	24.30	24.30	24.60	25.40	24.70	24.70	24.90	25.60

LEGEND

- Edb — Entering Dry Bulb
- Ewb — Entering Wet Bulb
- kW — Compressor Motor Power Input
- SHC — Sensible Heat Capacity (1000 Btuh) Gross
- TC — Total Capacity (1000 Btuh) Gross



COMBINATION RATINGS (cont)

UNIT 38AKS014

38AKS014/40RM012H WITH HIGH-CAPACITY 4-ROW COIL

Temp (F) Air Entering Condenser (Edb)		Evaporator Air — Cfm											
		3000				4000				5000			
		Evaporator Air — Ewb (F)											
		57	62	67	72	57	62	67	72	57	62	67	72
80	TC	121.0	130.0	142.0	156.0	134.0	139.0	151.0	164.0	143.0	145.0	156.0	170.0
	SHC	121.0	108.0	92.5	76.1	134.0	126.0	106.0	84.2	143.0	140.0	118.0	91.6
	kW	8.84	8.95	9.13	9.34	9.01	9.07	9.26	9.47	9.15	9.17	9.35	9.55
85	TC	119.0	127.0	140.0	153.0	132.0	136.0	148.0	161.0	141.0	142.0	153.0	166.0
	SHC	119.0	107.0	91.2	74.8	132.0	124.0	104.0	82.9	141.0	139.0	116.0	90.3
	kW	9.27	9.39	9.61	9.84	9.47	9.54	9.74	9.98	9.62	9.64	9.84	10.10
95	TC	115.0	122.0	134.0	146.0	127.0	130.0	141.0	154.0	135.0	136.0	146.0	159.0
	SHC	115.0	104.0	88.6	72.3	127.0	121.0	102.0	80.3	135.0	135.0	113.0	87.7
	kW	10.10	10.30	10.50	10.80	10.40	10.40	10.70	11.00	10.60	10.60	10.80	11.10
100	TC	113.0	119.0	131.0	143.0	124.0	127.0	138.0	150.0	133.0	133.0	142.0	155.0
	SHC	113.0	103.0	87.3	71.1	124.0	120.0	100.0	79.0	133.0	132.0	112.0	86.4
	kW	10.60	10.70	11.00	11.30	10.90	10.90	11.20	11.50	11.00	11.10	11.30	11.60
105	TC	110.0	116.0	127.0	140.0	122.0	124.0	134.0	147.0	130.0	130.0	139.0	151.0
	SHC	110.0	102.0	86.0	69.8	122.0	118.0	98.8	77.7	130.0	130.0	111.0	85.1
	kW	11.00	11.10	11.50	11.80	11.30	11.40	11.60	12.00	11.50	11.50	11.80	12.10
115	TC	106.0	110.0	121.0	133.0	117.0	118.0	127.0	139.0	124.0	124.0	132.0	143.0
	SHC	106.0	98.8	83.3	67.2	117.0	115.0	96.1	75.1	124.0	124.0	108.0	82.5
	kW	11.90	12.00	12.40	12.80	12.20	12.30	12.60	13.00	12.50	12.50	12.70	13.10

38AKS014/40RM012 WITH STANDARD 3-ROW COIL

Temp (F) Air Entering Condenser (Edb)		Evaporator Air — Cfm											
		3000				4000				5000			
		Evaporator Air — Ewb (F)											
		57	62	67	72	57	62	67	72	57	62	67	72
80	TC	116.0	124.0	136.0	149.0	128.0	132.0	144.0	157.0	136.0	138.0	149.0	162.0
	SHC	116.0	104.0	88.6	72.7	128.0	120.0	101.0	80.3	136.0	133.0	112.0	87.2
	kW	8.78	8.88	9.04	9.23	8.92	8.99	9.15	9.35	9.04	9.07	9.23	9.43
85	TC	114.0	121.0	133.0	146.0	126.0	129.0	141.0	154.0	134.0	135.0	146.0	158.0
	SHC	114.0	103.0	87.4	71.6	126.0	119.0	99.6	79.2	134.0	132.0	111.0	86.0
	kW	9.19	9.31	9.49	9.71	9.37	9.43	9.63	9.85	9.50	9.53	9.71	9.94
95	TC	110.0	116.0	128.0	140.0	121.0	124.0	135.0	147.0	129.0	130.0	139.0	152.0
	SHC	110.0	100.0	85.0	69.3	121.0	116.0	97.1	76.7	129.0	128.0	108.0	83.6
	kW	10.00	10.20	10.40	10.70	10.30	10.30	10.60	10.80	10.40	10.50	10.70	10.90
100	TC	108.0	114.0	125.0	137.0	119.0	121.0	132.0	144.0	126.0	127.0	136.0	148.0
	SHC	108.0	98.8	83.8	68.1	119.0	114.0	95.8	75.6	126.0	126.0	107.0	82.4
	kW	10.50	10.60	10.80	11.20	10.70	10.80	11.00	11.30	10.90	10.90	11.10	11.40
105	TC	106.0	111.0	122.0	134.0	116.0	118.0	129.0	140.0	124.0	124.0	133.0	145.0
	SHC	106.0	97.5	82.5	66.9	116.0	113.0	94.6	74.4	124.0	124.0	105.0	81.2
	kW	10.90	11.00	11.30	11.60	11.20	11.20	11.50	11.80	11.30	11.40	11.60	11.90
115	TC	102.0	106.0	116.0	128.0	112.0	113.0	122.0	134.0	119.0	119.0	126.0	137.0
	SHC	102.0	94.9	80.0	64.5	112.0	110.0	92.0	71.9	119.0	119.0	103.0	78.7
	kW	11.70	11.80	12.20	12.60	12.00	12.10	12.40	12.80	12.30	12.30	12.50	12.90

LEGEND

- Edb — Entering Dry Bulb
- Ewb — Entering Wet Bulb
- kW — Compressor Motor Power Input
- SHC — Sensible Heat Capacity (1000 Btuh) Gross
- TC — Total Capacity (1000 Btuh) Gross

38ARD_AKS014-024

Performance data (cont)



COMBINATION RATINGS (cont)

UNIT 38AKS014 (cont)

38AKS014/40RM014H WITH HIGH-CAPACITY 4-ROW COIL

Temp (F) Air Entering Condenser (Edb)		Evaporator Air — Cfm											
		3750				5000				6250			
		Evaporator Air — Ewb (F)											
		57	62	67	72	57	62	67	72	57	62	67	72
80	TC	133.0	139.0	151.0	165.0	146.0	147.0	158.0	172.0	154.0	154.0	163.0	177.0
	SHC	133.0	123.0	103.0	83.1	146.0	142.0	119.0	92.7	154.0	154.0	133.0	101.0
	KW	9.00	9.07	9.27	9.48	9.18	9.20	9.38	9.59	9.32	9.32	9.45	9.66
85	TC	131.0	136.0	148.0	161.0	143.0	144.0	155.0	169.0	152.0	151.0	160.0	173.0
	SHC	131.0	122.0	102.0	81.9	143.0	140.0	117.0	91.3	152.0	151.0	131.0	100.0
	KW	9.44	9.54	9.75	9.99	9.66	9.69	9.88	10.10	9.82	9.81	9.96	10.20
95	TC	126.0	130.0	142.0	155.0	138.0	138.0	148.0	161.0	146.0	146.0	153.0	165.0
	SHC	126.0	119.0	99.5	79.3	138.0	137.0	115.0	88.8	146.0	146.0	128.0	97.5
	KW	10.40	10.50	10.70	11.00	10.60	10.60	10.90	11.20	10.80	10.80	11.00	11.30
100	TC	123.0	127.0	138.0	151.0	135.0	135.0	145.0	157.0	143.0	143.0	149.0	161.0
	SHC	123.0	117.0	98.2	78.0	135.0	134.0	113.0	87.5	143.0	143.0	127.0	96.2
	KW	10.80	10.90	11.20	11.50	11.10	11.10	11.30	11.70	11.30	11.30	11.50	11.80
105	TC	121.0	124.0	135.0	148.0	132.0	132.0	141.0	154.0	140.0	140.0	145.0	157.0
	SHC	121.0	116.0	96.8	76.8	132.0	132.0	112.0	86.1	140.0	140.0	125.0	94.8
	KW	11.30	11.40	11.70	12.00	11.60	11.60	11.80	12.20	11.80	11.80	12.00	12.30
115	TC	116.0	118.0	129.0	141.0	127.0	127.0	134.0	146.0	134.0	134.0	138.0	149.0
	SHC	116.0	113.0	94.1	74.2	127.0	127.0	109.0	83.5	134.0	134.0	122.0	92.2
	KW	12.20	12.30	12.60	13.00	12.50	12.50	12.80	13.20	12.80	12.80	12.90	13.30

38AKS014/40RM014 WITH STANDARD 3-ROW COIL

Temp (F) Air Entering Condenser (Edb)		Evaporator Air — Cfm											
		3750				5000				6250			
		Evaporator Air — Ewb (F)											
		57	62	67	72	57	62	67	72	57	62	67	72
80	TC	127.0	134.0	146.0	160.0	140.0	142.0	153.0	167.0	148.0	148.0	158.0	172.0
	SHC	127.0	118.0	99.4	80.2	140.0	136.0	114.0	89.0	148.0	148.0	126.0	96.9
	KW	8.93	9.01	9.19	9.40	9.09	9.12	9.31	9.51	9.22	9.22	9.37	9.58
85	TC	125.0	131.0	143.0	156.0	137.0	139.0	150.0	163.0	145.0	145.0	154.0	168.0
	SHC	125.0	117.0	98.2	78.9	137.0	134.0	112.0	87.6	145.0	145.0	125.0	95.6
	KW	9.37	9.45	9.67	9.90	9.55	9.58	9.79	10.00	9.70	9.71	9.87	10.10
95	TC	121.0	125.0	137.0	150.0	132.0	133.0	143.0	156.0	140.0	140.0	147.0	160.0
	SHC	121.0	114.0	95.6	76.4	132.0	130.0	110.0	85.1	140.0	140.0	122.0	93.0
	KW	10.30	10.30	10.60	10.90	10.50	10.50	10.70	11.00	10.70	10.70	10.80	11.10
100	TC	118.0	122.0	134.0	146.0	129.0	130.0	140.0	152.0	137.0	137.0	144.0	156.0
	SHC	118.0	112.0	94.3	75.2	129.0	128.0	108.0	83.8	137.0	137.0	121.0	91.7
	KW	10.70	10.80	11.10	11.40	11.00	11.00	11.20	11.60	11.20	11.20	11.30	11.70
105	TC	116.0	119.0	131.0	143.0	127.0	127.0	136.0	149.0	134.0	134.0	140.0	153.0
	SHC	116.0	111.0	92.9	73.9	127.0	126.0	107.0	82.5	134.0	134.0	119.0	90.4
	KW	11.20	11.20	11.50	11.90	11.40	11.40	11.70	12.10	11.60	11.60	11.80	12.20
115	TC	111.0	113.0	124.0	136.0	121.0	121.0	129.0	141.0	128.0	128.0	133.0	145.0
	SHC	111.0	108.0	90.3	71.4	121.0	121.0	104.0	79.9	128.0	128.0	116.0	87.8
	KW	12.00	12.10	12.50	12.90	12.40	12.40	12.60	13.10	12.60	12.60	12.80	13.20

LEGEND

- Edb — Entering Dry Bulb
- Ewb — Entering Wet Bulb
- kW — Compressor Motor Power Input
- SHC — Sensible Heat Capacity (1000 Btuh) Gross
- TC — Total Capacity (1000 Btuh) Gross

38ARD_AKS014-024



COMBINATION RATINGS (cont)

UNIT 38AKS014 (cont)

38AKS014/40RM016H WITH HIGH-CAPACITY 4-ROW COIL													
Temp (F) Air Entering Condenser (Edb)		Evaporator Air — Cfm											
		4500				6000				7500			
		Evaporator Air — Ewb (F)											
		57	62	67	72	57	62	67	72	57	62	67	72
80	TC	142.0	145.0	157.0	171.0	154.0	154.0	164.0	178.0	163.0	163.0	168.0	182.0
	SHC	142.0	136.0	114.0	89.6	154.0	154.0	131.0	100.0	163.0	163.0	146.0	110.0
	kW	9.13	9.17	9.37	9.57	9.31	9.32	9.47	9.66	9.44	9.45	9.53	9.72
85	TC	140.0	142.0	154.0	168.0	151.0	151.0	160.0	174.0	160.0	160.0	165.0	178.0
	SHC	140.0	134.0	112.0	88.3	151.0	151.0	129.0	99.1	160.0	160.0	145.0	109.0
	kW	9.60	9.65	9.86	10.10	9.81	9.81	9.97	10.20	9.96	9.96	10.00	10.30
95	TC	134.0	136.0	147.0	160.0	146.0	146.0	153.0	166.0	153.0	153.0	157.0	170.0
	SHC	134.0	131.0	109.0	85.7	146.0	146.0	127.0	96.4	153.0	153.0	142.0	106.0
	kW	10.50	10.60	10.80	11.20	10.80	10.80	11.00	11.30	11.00	11.00	11.10	11.40
100	TC	132.0	133.0	144.0	157.0	143.0	143.0	150.0	162.0	150.0	150.0	154.0	166.0
	SHC	132.0	129.0	108.0	84.4	143.0	143.0	125.0	95.1	150.0	150.0	140.0	105.0
	kW	11.00	11.10	11.30	11.70	11.30	11.30	11.50	11.80	11.50	11.50	11.60	11.90
105	TC	129.0	130.0	140.0	153.0	140.0	140.0	146.0	158.0	147.0	147.0	150.0	162.0
	SHC	129.0	127.0	107.0	83.1	140.0	140.0	124.0	93.8	147.0	147.0	138.0	104.0
	kW	11.50	11.50	11.80	12.20	11.80	11.80	12.00	12.30	12.00	12.00	12.10	12.40
115	TC	124.0	124.0	133.0	146.0	134.0	134.0	139.0	150.0	140.0	140.0	142.0	153.0
	SHC	124.0	123.0	104.0	80.5	134.0	134.0	121.0	91.0	140.0	140.0	135.0	101.0
	kW	12.40	12.50	12.80	13.20	12.80	12.80	13.00	13.40	13.00	13.00	13.10	13.50

38AKS014/40RM016 WITH STANDARD 3-ROW COIL													
Temp (F) Air Entering Condenser (Edb)		Evaporator Air — Cfm											
		4500				6000				7500			
		Evaporator Air — Ewb (F)											
		57	62	67	72	57	62	67	72	57	62	67	72
80	TC	140.0	144.0	156.0	170.0	152.0	152.0	162.0	176.0	160.0	160.0	167.0	181.0
	SHC	140.0	134.0	112.0	88.3	152.0	152.0	128.0	98.7	160.0	160.0	143.0	108.0
	kW	9.09	9.14	9.34	9.55	9.28	9.28	9.44	9.65	9.41	9.41	9.51	9.71
85	TC	137.0	140.0	152.0	166.0	149.0	149.0	159.0	172.0	157.0	157.0	163.0	176.0
	SHC	137.0	132.0	110.0	87.0	149.0	149.0	127.0	97.3	157.0	157.0	142.0	107.0
	kW	9.56	9.61	9.84	10.10	9.78	9.77	9.94	10.20	9.92	9.92	10.00	10.20
95	TC	132.0	134.0	146.0	159.0	143.0	143.0	151.0	165.0	151.0	151.0	155.0	168.0
	SHC	132.0	129.0	107.0	84.4	143.0	143.0	124.0	94.6	151.0	151.0	138.0	104.0
	kW	10.50	10.50	10.80	11.10	10.70	10.70	10.90	11.20	10.90	10.90	11.00	11.30
100	TC	130.0	131.0	142.0	155.0	140.0	140.0	148.0	161.0	148.0	148.0	152.0	164.0
	SHC	130.0	127.0	106.0	83.1	140.0	140.0	123.0	93.3	148.0	148.0	137.0	103.0
	kW	11.00	11.00	11.30	11.60	11.30	11.20	11.40	11.80	11.40	11.40	11.50	11.80
105	TC	127.0	128.0	139.0	151.0	137.0	137.0	144.0	157.0	145.0	145.0	148.0	160.0
	SHC	127.0	125.0	105.0	81.7	137.0	137.0	12.01	91.9	145.0	145.0	135.0	101.0
	kW	11.40	11.50	11.80	12.10	11.70	11.70	11.90	12.30	11.90	11.90	12.00	12.40
115	TC	121.0	122.0	131.0	144.0	131.0	131.0	136.0	148.0	138.0	138.0	140.0	152.0
	SHC	121.0	121.0	102.0	79.0	131.0	131.0	118.0	89.2	138.0	138.0	132.0	98.7
	kW	12.40	12.40	12.70	13.10	12.70	12.70	12.90	13.30	12.90	12.90	13.00	13.40

LEGEND

- Edb** — Entering Dry Bulb
- Ewb** — Entering Wet Bulb
- kW** — Compressor Motor Power Input
- SHC** — Sensible Heat Capacity (1000 Btuh) Gross
- TC** — Total Capacity (1000 Btuh) Gross

38ARD_AKS014-024

Performance data (cont)



COMBINATION RATINGS (cont)

UNIT 38AKS016

38ARD_AKS014-024

38AKS016/40RM014H WITH HIGH-CAPACITY 4-ROW COIL													
Temp (F) Air Entering Condenser (Edb)		Evaporator Air — Cfm											
		3750				5000				6250			
		Evaporator Air — Ewb (F)											
		57	62	67	72	57	62	67	72	57	62	67	72
80	TC	159.0	171.0	186.0	203.0	175.0	182.0	197.0	214.0	187.0	190.0	204.0	221.0
	SHC	158.0	140.0	119.0	98.3	175.0	162.0	136.0	109.0	187.0	181.0	151.0	118.0
	KW	12.80	13.20	13.70	14.20	13.30	13.50	14.00	14.50	13.70	13.80	14.20	14.70
85	TC	156.0	168.0	183.0	199.0	172.0	178.0	193.0	210.0	184.0	186.0	200.0	217.0
	SHC	156.0	138.0	118.0	96.9	172.0	160.0	134.0	107.0	184.0	179.0	149.0	116.0
	KW	13.40	13.80	14.30	14.80	13.90	14.10	14.70	15.20	14.30	14.40	14.90	15.40
95	TC	151.0	161.0	176.0	192.0	167.0	171.0	186.0	202.0	178.0	179.0	192.0	208.0
	SHC	151.0	135.0	115.0	93.9	167.0	157.0	131.0	104.0	178.0	175.0	146.0	113.0
	KW	14.50	14.90	15.50	16.20	15.20	15.40	15.90	16.60	15.60	15.60	16.20	16.80
100	TC	148.0	158.0	173.0	188.0	164.0	168.0	182.0	197.0	174.0	175.0	188.0	203.0
	SHC	148.0	134.0	113.0	92.5	164.0	155.0	129.0	102.0	174.0	173.0	144.0	112.0
	KW	15.10	15.50	16.20	16.80	15.80	16.00	16.60	17.20	16.20	16.30	16.80	17.50
105	TC	146.0	155.0	169.0	184.0	161.0	164.0	178.0	193.0	171.0	172.0	184.0	199.0
	SHC	146.0	132.0	112.0	90.9	161.0	153.0	128.0	101.0	171.0	170.0	143.0	110.0
	KW	15.70	16.10	16.80	17.50	16.40	16.50	17.20	17.90	16.90	16.90	17.50	18.20
115	TC	141.0	148.0	162.0	176.0	155.0	157.0	170.0	185.0	164.0	165.0	175.0	190.0
	SHC	141.0	129.0	109.0	87.8	155.0	150.0	125.0	97.8	164.0	164.0	139.0	107.0
	KW	16.80	17.20	18.00	18.80	17.60	17.70	18.40	19.20	18.10	18.10	18.70	19.50

38AKS016/40RM014 WITH STANDARD 3-ROW COIL													
Temp (F) Air Entering Condenser (Edb)		Evaporator Air — Cfm											
		3750				5000				6250			
		Evaporator Air — Ewb (F)											
		57	62	67	72	57	62	67	72	57	62	67	72
80	TC	149.0	161.0	176.0	192.0	164.0	171.0	186.0	202.0	175.0	179.0	193.0	209.0
	SHC	148.0	132.0	113.0	93.0	164.0	152.0	127.0	102.0	175.0	168.0	140.0	110.0
	KW	12.50	12.90	13.40	13.80	13.00	13.20	13.70	14.20	13.30	13.40	13.90	14.40
85	TC	147.0	158.0	173.0	188.0	161.0	168.0	183.0	199.0	172.0	175.0	189.0	205.0
	SHC	146.0	130.0	111.0	91.6	161.0	150.0	126.0	101.0	172.0	166.0	139.0	109.0
	KW	13.10	13.50	14.00	14.50	13.50	13.80	14.30	14.80	13.90	14.00	14.50	15.00
95	TC	142.0	152.0	167.0	181.0	156.0	162.0	176.0	191.0	166.0	168.0	182.0	197.0
	SHC	142.0	127.0	108.0	88.7	156.0	147.0	123.0	97.8	166.0	162.0	136.0	106.0
	KW	14.20	14.60	15.10	15.70	14.70	15.00	15.50	16.10	15.10	15.20	15.80	16.40
100	TC	139.0	149.0	163.0	178.0	153.0	158.0	172.0	187.0	163.0	165.0	178.0	193.0
	SHC	139.0	126.0	107.0	87.3	153.0	145.0	121.0	96.3	163.0	160.0	134.0	104.0
	KW	14.70	15.10	15.70	16.40	15.30	15.50	16.10	16.80	15.70	15.80	16.40	17.00
105	TC	137.0	146.0	160.0	174.0	151.0	155.0	168.0	183.0	160.0	161.0	174.0	188.0
	SHC	137.0	124.0	105.0	85.9	151.0	143.0	120.0	94.9	160.0	158.0	133.0	103.0
	KW	15.30	15.70	16.30	17.00	15.90	16.10	16.70	17.40	16.30	16.40	17.00	17.70
115	TC	132.0	140.0	153.0	167.0	145.0	148.0	161.0	175.0	154.0	155.0	166.0	180.0
	SHC	132.0	121.0	102.0	83.0	145.0	140.0	117.0	91.8	154.0	153.0	130.0	99.9
	KW	16.40	16.80	17.50	18.20	17.10	17.20	17.90	18.70	17.60	17.60	18.20	19.00

LEGEND

- Edb — Entering Dry Bulb
- Ewb — Entering Wet Bulb
- kW — Compressor Motor Power Input
- SHC — Sensible Heat Capacity (1000 Btuh) Gross
- TC — Total Capacity (1000 Btuh) Gross



COMBINATION RATINGS (cont)

UNIT 38AKS016 (cont)

38AKS016/40RM016H WITH HIGH-CAPACITY 4-ROW COIL													
Temp (F) Air Entering Condenser (Edb)		Evaporator Air — Cfm											
		4500				6000				7500			
		Evaporator Air — Ewb (F)											
		57	62	67	72	57	62	67	72	57	62	67	72
80	TC	167.0	177.0	192.0	209.0	183.0	187.0	202.0	219.0	194.0	195.0	208.0	225.0
	SHC	167.0	152.0	128.0	104.0	183.0	175.0	146.0	115.0	194.0	193.0	163.0	125.0
	kW	13.10	13.40	13.90	14.40	13.60	13.70	14.10	14.70	13.90	13.90	14.30	14.80
85	TC	165.0	174.0	189.0	205.0	180.0	184.0	198.0	214.0	191.0	192.0	204.0	220.0
	SHC	165.0	150.0	127.0	102.0	180.0	174.0	145.0	113.0	191.0	191.0	161.0	124.0
	kW	13.70	14.00	14.50	15.00	14.20	14.30	14.80	15.30	14.60	14.60	15.00	15.50
95	TC	160.0	167.0	182.0	197.0	174.0	177.0	190.0	206.0	185.0	185.0	196.0	211.0
	SHC	160.0	147.0	123.0	99.3	174.0	170.0	141.0	110.0	185.0	185.0	158.0	120.0
	kW	14.90	15.20	15.70	16.40	15.50	15.60	16.10	16.70	15.90	15.90	16.30	16.90
100	TC	157.0	164.0	178.0	193.0	171.0	173.0	186.0	202.0	181.0	181.0	191.0	207.0
	SHC	157.0	145.0	122.0	97.8	171.0	168.0	140.0	109.0	181.0	181.0	156.0	119.0
	kW	15.50	15.80	16.40	17.00	16.10	16.20	16.70	17.40	16.50	16.50	17.00	17.60
105	TC	154.0	160.0	174.0	189.0	168.0	169.0	182.0	197.0	178.0	178.0	187.0	202.0
	SHC	154.0	144.0	120.0	96.3	168.0	165.0	138.0	107.0	178.0	178.0	154.0	117.0
	kW	16.00	16.30	17.00	17.70	16.70	16.80	17.40	18.10	17.20	17.20	17.60	18.30
115	TC	148.0	153.0	166.0	181.0	162.0	162.0	174.0	188.0	171.0	171.0	178.0	193.0
	SHC	148.0	140.0	117.0	93.2	162.0	161.0	135.0	104.0	171.0	171.0	151.0	114.0
	kW	17.30	17.50	18.20	19.00	18.00	18.00	18.60	19.40	18.50	18.50	18.90	19.70

38AKS016/40RM016 WITH STANDARD 3-ROW COIL													
Temp (F) Air Entering Condenser (Edb)		Evaporator Air — Cfm											
		4500				6000				7500			
		Evaporator Air — Ewb (F)											
		57	62	67	72	57	62	67	72	57	62	67	72
80	TC	165.0	175.0	190.0	207.0	180.0	185.0	200.0	217.0	191.0	193.0	206.0	223.0
	SHC	165.0	149.0	126.0	102.0	180.0	172.0	143.0	113.0	191.0	190.0	159.0	123.0
	kW	13.00	13.30	13.80	14.30	13.50	13.60	14.10	14.60	13.80	13.90	14.30	14.80
85	TC	162.0	171.0	187.0	203.0	177.0	181.0	196.0	213.0	188.0	189.0	202.0	218.0
	SHC	162.0	148.0	125.0	101.0	177.0	170.0	142.0	112.0	188.0	187.0	158.0	121.0
	kW	13.60	13.90	14.40	15.00	14.10	14.20	14.70	15.30	14.50	14.50	14.90	15.50
95	TC	157.0	165.0	179.0	195.0	171.0	174.0	188.0	204.0	182.0	182.0	193.0	209.0
	SHC	157.0	144.0	121.0	97.9	171.0	166.0	139.0	108.0	182.0	181.0	154.0	118.0
	kW	14.80	15.10	15.70	16.30	15.30	15.50	16.00	16.60	15.80	15.80	16.20	16.90
100	TC	154.0	161.0	176.0	191.0	168.0	170.0	184.0	199.0	178.0	178.0	189.0	205.0
	SHC	154.0	143.0	120.0	96.3	168.0	164.0	137.0	107.0	178.0	178.0	153.0	117.0
	kW	15.30	15.70	16.30	17.00	16.00	16.10	16.70	17.30	16.40	16.40	16.90	17.50
105	TC	151.0	158.0	172.0	187.0	165.0	167.0	180.0	195.0	175.0	175.0	185.0	200.0
	SHC	151.0	141.0	118.0	94.8	165.0	162.0	135.0	105.0	175.0	175.0	151.0	115.0
	kW	15.90	16.20	16.90	17.60	16.60	16.70	17.30	18.00	17.00	17.00	17.50	18.20
115	TC	146.0	151.0	164.0	179.0	159.0	160.0	171.0	186.0	168.0	168.0	176.0	191.0
	SHC	146.0	137.0	115.0	91.7	159.0	157.0	132.0	102.0	168.0	168.0	147.0	112.0
	kW	17.10	17.40	18.10	18.90	17.80	17.90	18.50	19.30	18.30	18.30	18.80	19.50

LEGEND

- Edb** — Entering Dry Bulb
- Ewb** — Entering Wet Bulb
- kW** — Compressor Motor Power Input
- SHC** — Sensible Heat Capacity (1000 Btuh) Gross
- TC** — Total Capacity (1000 Btuh) Gross

38ARD_AKS014-024

Performance data (cont)



COMBINATION RATINGS (cont)

UNIT 38AKS016 (cont)

38ARD_AKS014-024

38AKS016/40RM024H WITH HIGH-CAPACITY 4-ROW COIL													
Temp (F) Air Entering Condenser (Edb)		Evaporator Air — Cfm											
		6,000				8,000				10,000			
		Evaporator Air — Ewb (F)											
		57	62	67	72	57	62	67	72	57	62	67	72
80	TC	196.0	200.0	215.0	234.0	212.0	212.0	224.0	242.0	223.0	224.0	230.0	247.0
	SHC	196.0	188.0	156.0	123.0	212.0	212.0	181.0	138.0	223.0	224.0	203.0	152.0
	kW	13.90	14.00	14.50	15.00	14.40	14.40	14.70	15.20	14.70	14.70	14.90	15.30
85	TC	193.0	196.0	211.0	229.0	209.0	209.0	220.0	237.0	219.0	220.0	225.0	242.0
	SHC	193.0	186.0	154.0	121.0	209.0	209.0	179.0	136.0	219.0	220.0	201.0	151.0
	kW	14.60	14.70	15.20	15.70	15.10	15.10	15.40	16.00	15.40	15.40	15.60	16.10
95	TC	186.0	188.0	203.0	219.0	201.0	201.0	210.0	227.0	211.0	211.0	216.0	231.0
	SHC	186.0	182.0	151.0	118.0	201.0	201.0	175.0	133.0	211.0	211.0	197.0	147.0
	kW	15.90	16.00	16.50	17.10	16.50	16.50	16.80	17.40	16.80	16.80	17.00	17.60
100	TC	183.0	184.0	198.0	215.0	197.0	197.0	205.0	222.0	207.0	207.0	211.0	226.0
	SHC	183.0	179.0	149.0	116.0	197.0	197.0	173.0	131.0	207.0	207.0	195.0	146.0
	kW	16.50	16.60	17.20	17.90	17.20	17.10	17.50	18.10	17.60	17.50	17.70	18.30
105	TC	179.0	180.0	193.0	210.0	193.0	193.0	201.0	216.0	203.0	203.0	206.0	221.0
	SHC	179.0	177.0	147.0	114.0	193.0	193.0	171.0	129.0	203.0	203.0	192.0	144.0
	kW	17.20	17.20	17.80	18.60	17.80	17.80	18.20	18.90	18.30	18.30	18.40	19.00
115	TC	172.0	172.0	184.0	200.0	185.0	185.0	191.0	206.0	194.0	194.0	196.0	210.0
	SHC	172.0	172.0	144.0	111.0	185.0	185.0	168.0	126.0	194.0	194.0	188.0	140.0
	kW	18.50	18.50	19.10	20.00	19.20	19.20	19.50	20.30	19.70	19.70	19.80	20.50

38AKS016/40RM024 WITH STANDARD 3-ROW COIL													
Temp (F) Air Entering Condenser (Edb)		Evaporator Air — Cfm											
		6,000				8,000				10,000			
		Evaporator Air — Ewb (F)											
		57	62	67	72	57	62	67	72	57	62	67	72
80	TC	186.0	190.0	205.0	222.0	201.0	201.0	212.0	230.0	211.0	211.0	218.0	235.0
	SHC	186.0	178.0	148.0	117.0	201.0	201.0	171.0	130.0	211.0	211.0	190.0	143.0
	kW	13.70	13.80	14.20	14.70	14.10	14.10	14.50	15.00	14.40	14.40	14.60	15.10
85	TC	183.0	186.0	200.0	217.0	197.0	197.0	208.0	225.0	207.0	207.0	213.0	230.0
	SHC	183.0	176.0	147.0	115.0	197.0	197.0	169.0	129.0	207.0	207.0	188.0	142.0
	kW	14.30	14.40	14.90	15.40	14.80	14.80	15.10	15.70	15.10	15.10	15.30	15.80
95	TC	176.0	179.0	192.0	208.0	190.0	190.0	199.0	215.0	199.0	199.0	204.0	220.0
	SHC	176.0	172.0	143.0	112.0	190.0	190.0	165.0	125.0	199.0	199.0	184.0	138.0
	kW	15.50	15.60	16.20	16.80	16.10	16.10	16.50	17.10	16.50	16.50	16.70	17.30
100	TC	173.0	175.0	188.0	204.0	186.0	186.0	195.0	211.0	195.0	195.0	200.0	215.0
	SHC	173.0	170.0	142.0	110.0	186.0	186.0	163.0	124.0	195.0	195.0	182.0	137.0
	kW	16.20	16.20	16.80	17.50	16.80	16.70	17.10	17.80	17.10	17.10	17.30	18.00
105	TC	170.0	171.0	184.0	199.0	183.0	183.0	190.0	206.0	191.0	191.0	195.0	210.0
	SHC	170.0	167.0	140.0	108.0	183.0	183.0	162.0	122.0	191.0	191.0	180.0	135.0
	kW	16.80	16.90	17.50	18.20	17.40	17.40	17.80	18.50	17.80	17.80	18.00	18.70
115	TC	163.0	164.0	175.0	190.0	175.0	175.0	181.0	196.0	183.0	183.0	186.0	199.0
	SHC	163.0	163.0	136.0	105.0	175.0	175.0	158.0	119.0	183.0	183.0	175.0	132.0
	kW	18.10	18.10	18.70	19.50	18.70	18.70	19.10	19.80	19.20	19.10	19.30	20.00

LEGEND

- Edb — Entering Dry Bulb
- Ewb — Entering Wet Bulb
- kW — Compressor Motor Power Input
- SHC — Sensible Heat Capacity (1000 Btuh) Gross
- TC — Total Capacity (1000 Btuh) Gross



COMBINATION RATINGS (cont)

UNIT 38AKS024

38AKS024/40RM016H WITH HIGH-CAPACITY 4-ROW COIL

Temp (F) Air Entering Condenser (Edb)		Evaporator Air — Cfm											
		4500				6000				7500			
		Evaporator Air — Ewb (F)											
		57	62	67	72	57	62	67	72	57	62	67	72
80	TC	190.0	206.0	224.0	244.0	209.0	219.0	238.0	258.0	223.0	228.0	247.0	267.0
	SHC	187.0	166.0	142.0	118.0	209.0	192.0	161.0	130.0	223.0	214.0	178.0	140.0
	kW	16.80	17.40	18.20	19.00	17.60	18.00	18.70	19.50	18.10	18.30	19.10	19.90
85	TC	187.0	202.0	220.0	240.0	205.0	215.0	233.0	253.0	219.0	224.0	241.0	261.0
	SHC	185.0	164.0	140.0	116.0	205.0	189.0	159.0	128.0	219.0	211.0	176.0	138.0
	kW	17.50	18.10	18.90	19.70	18.30	18.70	19.50	20.30	18.90	19.10	19.80	20.60
95	TC	180.0	193.0	211.0	230.0	198.0	206.0	223.0	242.0	211.0	214.0	231.0	250.0
	SHC	180.0	160.0	136.0	112.0	198.0	185.0	155.0	124.0	211.0	206.0	172.0	134.0
	kW	18.70	19.40	20.30	21.30	19.70	20.00	20.90	21.80	20.30	20.50	21.30	22.20
100	TC	176.0	189.0	207.0	225.0	195.0	201.0	218.0	237.0	207.0	210.0	226.0	244.0
	SHC	176.0	158.0	134.0	110.0	195.0	183.0	153.0	122.0	207.0	203.0	170.0	132.0
	kW	19.40	20.10	21.00	22.00	20.40	20.70	21.60	22.60	21.10	21.20	22.00	23.00
105	TC	173.0	185.0	202.0	220.0	191.0	197.0	213.0	232.0	203.0	205.0	220.0	239.0
	SHC	173.0	156.0	132.0	108.0	191.0	180.0	151.0	120.0	203.0	200.0	168.0	130.0
	kW	20.10	20.70	21.70	22.80	21.10	21.40	22.30	23.40	21.80	21.90	22.70	23.80
115	TC	167.0	177.0	193.0	210.0	183.0	187.0	203.0	220.0	195.0	196.0	209.0	227.0
	SHC	167.0	152.0	128.0	104.0	183.0	176.0	147.0	116.0	195.0	194.0	163.0	126.0
	kW	21.40	22.00	23.10	24.20	22.50	22.70	23.80	24.90	23.20	23.30	24.20	25.30

38AKS024/40RM016 WITH STANDARD 3-ROW COIL

Temp (F) Air Entering Condenser (Edb)		Evaporator Air — Cfm											
		4500				6000				7500			
		Evaporator Air — Ewb (F)											
		57	62	67	72	57	62	67	72	57	62	67	72
80	TC	188.0	203.0	222.0	242.0	205.0	216.0	235.0	256.0	220.0	226.0	244.0	265.0
	SHC	184.0	164.0	140.0	116.0	205.0	188.0	158.0	128.0	220.0	209.0	175.0	138.0
	kW	16.70	17.30	18.10	18.90	17.40	17.90	18.60	19.40	18.00	18.20	19.00	19.80
85	TC	184.0	199.0	217.0	237.0	202.0	212.0	231.0	250.0	216.0	221.0	239.0	259.0
	SHC	182.0	161.0	138.0	114.0	202.0	186.0	156.0	126.0	216.0	207.0	173.0	136.0
	kW	17.30	18.00	18.80	19.60	18.10	18.50	19.30	20.20	18.70	18.90	19.70	20.50
95	TC	177.0	191.0	209.0	227.0	195.0	203.0	221.0	240.0	208.0	211.0	228.0	248.0
	SHC	176.0	157.0	134.0	111.0	195.0	181.0	152.0	122.0	208.0	201.0	168.0	132.0
	kW	18.60	19.30	20.20	21.10	19.50	19.90	20.80	21.70	20.10	20.30	21.20	22.10
100	TC	174.0	186.0	204.0	222.0	191.0	198.0	216.0	234.0	204.0	207.0	223.0	242.0
	SHC	173.0	155.0	132.0	109.0	191.0	179.0	150.0	120.0	204.0	199.0	166.0	130.0
	kW	19.20	19.90	20.90	21.80	20.20	20.60	21.50	22.50	20.90	21.00	21.90	22.90
105	TC	170.0	182.0	199.0	218.0	187.0	194.0	210.0	229.0	200.0	202.0	218.0	236.0
	SHC	170.0	153.0	130.0	107.0	187.0	177.0	148.0	118.0	200.0	196.0	164.0	128.0
	kW	19.90	20.60	21.50	22.60	20.90	21.20	22.20	23.20	21.60	21.70	22.60	23.60
115	TC	164.0	174.0	190.0	207.0	180.0	184.0	200.0	218.0	191.0	192.0	207.0	224.0
	SHC	164.0	149.0	126.0	103.0	180.0	172.0	144.0	113.0	191.0	190.0	159.0	123.0
	kW	21.20	21.90	22.90	24.00	22.30	22.60	23.60	24.70	23.00	23.10	24.00	25.10

LEGEND

- Edb — Entering Dry Bulb
- Ewb — Entering Wet Bulb
- kW — Compressor Motor Power Input
- SHC — Sensible Heat Capacity (1000 Btuh) Gross
- TC — Total Capacity (1000 Btuh) Gross

38ARD_AKS014-024

Performance data (cont)



COMBINATION RATINGS (cont)

UNIT 38AKS024 (cont)

38ARD_AKS014-024

38AKS024/40RM024H WITH HIGH-CAPACITY 4-ROW COIL													
Temp (F) Air Entering Condenser (Edb)		Evaporator Air — Cfm											
		6,000				8,000				10,000			
		Evaporator Air — Ewb (F)											
		57	62	67	72	57	62	67	72	57	62	67	72
80	TC	224.0	234.0	254.0	276.0	245.0	248.0	266.0	288.0	260.0	260.0	274.0	296.0
	SHC	224.0	205.0	172.0	138.0	245.0	238.0	198.0	154.0	260.0	260.0	221.0	169.0
	KW	18.20	18.60	19.40	20.20	19.00	19.10	19.80	20.70	19.60	19.60	20.10	21.00
85	TC	220.0	230.0	249.0	271.0	240.0	243.0	261.0	282.0	255.0	255.0	268.0	289.0
	SHC	220.0	203.0	170.0	136.0	240.0	235.0	195.0	152.0	255.0	255.0	219.0	167.0
	KW	18.90	19.30	20.10	21.00	19.80	19.90	20.60	21.50	20.40	20.40	20.90	21.80
95	TC	212.0	220.0	238.0	259.0	231.0	233.0	249.0	269.0	245.0	245.0	256.0	276.0
	SHC	212.0	198.0	165.0	132.0	231.0	229.0	191.0	148.0	245.0	245.0	214.0	162.0
	KW	20.40	20.70	21.60	22.60	21.30	21.30	22.10	23.10	21.90	22.00	22.50	23.40
100	TC	208.0	215.0	233.0	253.0	227.0	227.0	243.0	263.0	240.0	240.0	250.0	269.0
	SHC	208.0	195.0	163.0	130.0	227.0	225.0	188.0	145.0	240.0	240.0	211.0	160.0
	KW	21.10	21.40	22.40	23.40	22.10	22.10	22.90	23.90	22.70	22.70	23.30	24.30
105	TC	204.0	210.0	227.0	247.0	222.0	222.0	237.0	256.0	234.0	234.0	243.0	262.0
	SHC	204.0	193.0	161.0	128.0	222.0	222.0	186.0	143.0	234.0	234.0	209.0	158.0
	KW	21.80	22.10	23.10	24.20	22.80	22.80	23.70	24.70	23.50	23.50	24.00	25.10
115	TC	196.0	199.0	216.0	235.0	212.0	212.0	225.0	243.0	224.0	224.0	231.0	249.0
	SHC	196.0	188.0	156.0	123.0	212.0	212.0	181.0	138.0	224.0	224.0	204.0	153.0
	KW	23.30	23.50	24.60	25.80	24.40	24.40	25.10	26.30	25.10	25.10	25.50	26.60

38AKS024/40RM024 WITH STANDARD 3-ROW COIL													
Temp (F) Air Entering Condenser (Edb)		Evaporator Air — Cfm											
		6,000				8,000				10,000			
		Evaporator Air — Ewb (F)											
		57	62	67	72	57	62	67	72	57	62	67	72
80	TC	212.0	222.0	242.0	263.0	231.0	235.0	253.0	274.0	245.0	245.0	260.0	281.0
	SHC	212.0	195.0	164.0	132.0	231.0	224.0	187.0	146.0	245.0	245.0	208.0	159.0
	KW	17.70	18.10	18.90	19.70	18.50	18.60	19.30	20.10	19.00	19.00	19.60	20.40
85	TC	209.0	218.0	237.0	257.0	227.0	230.0	248.0	268.0	240.0	240.0	255.0	275.0
	SHC	209.0	192.0	162.0	130.0	227.0	221.0	185.0	144.0	240.0	240.0	206.0	157.0
	KW	18.40	18.80	19.60	20.50	19.20	19.30	20.10	20.90	19.80	19.80	20.40	21.20
95	TC	201.0	209.0	226.0	246.0	219.0	220.0	236.0	256.0	231.0	231.0	243.0	262.0
	SHC	201.0	188.0	157.0	126.0	219.0	215.0	180.0	140.0	231.0	231.0	201.0	153.0
	KW	19.80	20.20	21.10	22.00	20.70	20.80	21.50	22.50	21.30	21.30	21.90	22.80
100	TC	197.0	204.0	221.0	240.0	214.0	215.0	231.0	250.0	226.0	226.0	237.0	256.0
	SHC	197.0	185.0	155.0	123.0	214.0	212.0	178.0	138.0	226.0	226.0	198.0	150.0
	KW	20.50	20.90	21.80	22.80	21.40	21.50	22.30	23.30	22.00	22.00	22.60	23.60
105	TC	193.0	199.0	216.0	235.0	210.0	211.0	225.0	244.0	221.0	221.0	231.0	250.0
	SHC	193.0	183.0	153.0	121.0	210.0	209.0	176.0	135.0	221.0	221.0	196.0	148.0
	KW	21.20	21.50	22.50	23.60	22.10	22.20	23.00	24.00	22.80	22.80	23.30	24.40
115	TC	186.0	190.0	205.0	223.0	201.0	201.0	214.0	231.0	212.0	212.0	219.0	237.0
	SHC	186.0	178.0	149.0	117.0	201.0	201.0	171.0	131.0	212.0	212.0	191.0	144.0
	KW	22.60	22.90	23.90	25.10	23.70	23.60	24.40	25.60	24.30	24.30	24.80	25.90

LEGEND

- Edb — Entering Dry Bulb
- Ewb — Entering Wet Bulb
- kW — Compressor Motor Power Input
- SHC — Sensible Heat Capacity (1000 Btuh) Gross
- TC — Total Capacity (1000 Btuh) Gross



COMBINATION RATINGS (cont)

UNIT 38AKS024 (cont)

38AKS024/40RM028H WITH HIGH-CAPACITY 4-ROW COIL													
Temp (F) Air Entering Condenser (Edb)		Evaporator Air — Cfm											
		7,500				10,000				12,500			
		Evaporator Air — Ewb (F)											
		57	62	67	72	57	62	67	72	57	62	67	72
80	TC	244.0	249.0	268.0	291.0	264.0	264.0	279.0	301.0	278.0	278.0	286.0	307.0
	SHC	244.0	233.0	194.0	152.0	264.0	264.0	224.0	171.0	278.0	278.0	252.0	189.0
	kW	18.90	19.20	19.90	20.80	19.70	19.70	20.30	21.20	20.30	20.30	20.60	21.40
85	TC	239.0	244.0	263.0	284.0	259.0	259.0	273.0	294.0	272.0	272.0	280.0	300.0
	SHC	239.0	231.0	192.0	150.0	259.0	259.0	222.0	169.0	272.0	272.0	249.0	187.0
	kW	19.70	19.90	20.70	21.60	20.50	20.50	21.10	22.00	21.10	21.10	21.40	22.30
95	TC	230.0	233.0	251.0	272.0	249.0	249.0	260.0	281.0	261.0	261.0	267.0	286.0
	SHC	230.0	225.0	187.0	146.0	249.0	249.0	217.0	164.0	261.0	261.0	243.0	182.0
	kW	21.30	21.40	22.20	23.20	22.10	22.10	22.70	23.70	22.70	22.70	23.00	23.90
100	TC	226.0	228.0	245.0	265.0	244.0	244.0	254.0	274.0	256.0	256.0	260.0	279.0
	SHC	226.0	222.0	184.0	143.0	244.0	244.0	214.0	162.0	256.0	256.0	240.0	180.0
	kW	22.00	22.10	23.00	24.00	22.90	22.90	23.50	24.50	23.60	23.60	23.80	24.80
105	TC	221.0	222.0	239.0	259.0	238.0	238.0	247.0	267.0	250.0	250.0	254.0	272.0
	SHC	221.0	219.0	182.0	141.0	238.0	238.0	212.0	160.0	250.0	250.0	237.0	177.0
	kW	22.80	22.80	23.70	24.80	23.70	23.70	24.20	25.30	24.40	24.40	24.60	25.60
115	TC	212.0	212.0	226.0	245.0	227.0	227.0	235.0	253.0	238.0	238.0	240.0	257.0
	SHC	212.0	211.0	177.0	136.0	227.0	227.0	206.0	155.0	238.0	238.0	231.0	172.0
	kW	24.30	24.30	25.20	26.40	25.30	25.30	25.80	26.90	26.00	26.00	26.10	27.20

38AKS024/40RM028 WITH STANDARD 3-ROW COIL													
Temp (F) Air Entering Condenser (Edb)		Evaporator Air — Cfm											
		7,500				10,000				12,500			
		Evaporator Air — Ewb (F)											
		57	62	67	72	57	62	67	72	57	62	67	72
80	TC	230.0	236.0	255.0	277.0	249.0	249.0	266.0	287.0	262.0	262.0	272.0	293.0
	SHC	230.0	219.0	183.0	144.0	249.0	248.0	209.0	161.0	262.0	262.0	233.0	176.0
	kW	18.40	18.60	19.40	20.20	19.10	19.20	19.80	20.60	19.60	19.60	20.10	20.90
85	TC	226.0	231.0	250.0	271.0	244.0	244.0	259.0	281.0	256.0	256.0	266.0	287.0
	SHC	226.0	217.0	181.0	142.0	244.0	244.0	207.0	159.0	256.0	256.0	231.0	174.0
	kW	19.20	19.40	20.20	21.00	19.90	19.90	20.60	21.50	20.40	20.40	20.80	21.70
95	TC	218.0	221.0	239.0	259.0	235.0	235.0	248.0	268.0	246.0	246.0	254.0	273.0
	SHC	218.0	211.0	176.0	138.0	235.0	235.0	203.0	154.0	246.0	246.0	226.0	169.0
	kW	20.60	20.80	21.70	22.60	21.50	21.50	22.10	23.10	22.00	22.00	22.40	23.30
100	TC	214.0	217.0	233.0	253.0	230.0	230.0	242.0	261.0	241.0	241.0	248.0	266.0
	SHC	214.0	208.0	174.0	136.0	230.0	230.0	200.0	152.0	241.0	241.0	223.0	167.0
	kW	21.40	21.50	22.40	23.40	22.20	22.20	22.90	23.80	22.80	22.80	23.20	24.10
105	TC	209.0	212.0	228.0	247.0	225.0	225.0	236.0	255.0	236.0	236.0	242.0	260.0
	SHC	209.0	206.0	172.0	133.0	225.0	225.0	198.0	150.0	236.0	236.0	220.0	165.0
	kW	22.10	22.20	23.10	24.20	23.00	23.00	23.60	24.60	23.60	23.60	23.90	24.90
115	TC	201.0	202.0	216.0	235.0	215.0	215.0	224.0	242.0	226.0	226.0	229.0	246.0
	SHC	201.0	199.0	167.0	129.0	215.0	215.0	193.0	145.0	226.0	226.0	214.0	160.0
	kW	23.60	23.70	24.60	25.80	24.60	24.50	25.10	26.20	25.20	25.20	25.40	26.50

LEGEND

- Edb** — Entering Dry Bulb
- Ewb** — Entering Wet Bulb
- kW** — Compressor Motor Power Input
- SHC** — Sensible Heat Capacity (1000 Btuh) Gross
- TC** — Total Capacity (1000 Btuh) Gross

38ARD_AKS014-024

Electrical data



38ARD014-024

UNIT 38AR	FACTORY- INSTALLED OPTION	NOMINAL VOLTAGE (3 Ph, 60 Hz)	VOLTAGE RANGE*		COMPRESSOR 1		COMPRESSOR 2		FAN MOTORS (Qty 2)			POWER SUPPLY		
			Min	Max	RLA	LRA	RLA	LRA	FLA (ea) Fan No.		kW	MCA	MOCP†	ICF
									1	2				
D014	NONE OR DISCONNECT CONVENIENCE OUTLET	208/230	187	253	20.7	156	20.7	156	4.3	3.7	1.41	55.6	70	186
												63.5	80	194
	NONE OR DISCONNECT CONVENIENCE OUTLET	460	414	528	10.0	75	10.0	75	2.3	1.9	1.41	27.7	35	90
												31.3	40	94
D016	NONE OR DISCONNECT CONVENIENCE OUTLET	575	518	660	8.2	54	8.2	54	1.8	1.8	1.41	23.1	30	67
												25.9	30	70
	NONE OR DISCONNECT CONVENIENCE OUTLET	380**	342	418	10.7	70	10.7	70	4.3	3.7	1.41	33.1	40	90
												37.4	45	94
D024	NONE OR DISCONNECT CONVENIENCE OUTLET	208/230	187	253	32.1	195	32.1	195	4.3	3.7	1.41	81.2	100	236
												89.2	100	244
	NONE OR DISCONNECT CONVENIENCE OUTLET	460	414	528	16.4	95	16.4	95	2.3	1.9	1.41	42.1	50	117
												45.7	60	120
D024	NONE OR DISCONNECT CONVENIENCE OUTLET	575	518	660	12.0	80	12.0	80	1.8	1.8	1.41	31.6	40	97
												34.5	40	99
	NONE OR DISCONNECT CONVENIENCE OUTLET	380**	342	418	16.7	123	16.7	123	4.3	3.7	1.41	46.6	60	149
												50.9	60	153
D024	NONE OR DISCONNECT CONVENIENCE OUTLET	208/230	187	253	37.8	239	37.8	239	4.3	3.7	1.41	94.1	125	286
												102.0	150	294
	NONE OR DISCONNECT CONVENIENCE OUTLET	460	414	528	19.2	125	19.2	125	2.3	1.9	1.41	48.4	60	149
												52.0	70	153
D024	NONE OR DISCONNECT CONVENIENCE OUTLET	575	518	660	13.8	80	13.8	80	1.8	1.8	1.41	35.7	45	98
												38.5	50	101
	NONE OR DISCONNECT CONVENIENCE OUTLET	380**	342	418	23.5	145	23.5	145	4.3	3.7	1.41	61.9	70	178
												66.2	80	182

38AKS014-024

UNIT 38AK	NOMINAL VOLTAGE (3-Ph, 60 Hz)	VOLTAGE RANGE*		COMPRESSOR		FAN MOTORS (Qty 2)			POWER SUPPLY		
		Min	Max	RLA	LRA	FLA (ea) Fan No.		kW	MCA	MOCP†	ICF
						1	2				
S014	208/230	187	253	49.3	191	4.3	3.7	1.41	69.6	100	199
	380**	342	418	26.5	104	4.3	3.7		38.5	60	112
	460	414	528	22.1	80	2.3	1.9		31.7	50	84
	575	518	660	17.9	69	1.8	1.8		25.6	40	73
S016	208/230	187	253	63.6	266	4.3	3.7	1.41	87.5	125	274
	380**	342	418	36.0	145	4.3	3.7		49.3	80	153
	460	414	528	29.3	120	2.3	1.9		40.7	60	124
	575	518	660	23.8	96	1.8	1.8		33.0	50	100
S024	208/230	187	254	67.9	345	4.3	3.7	1.41	93.4	150	353
	380**	342	418	34.6	191	4.3	3.7		49.7	80	199
	460	414	508	34.7	173	2.3	1.9		48.1	80	177
	575	518	632	28.8	120	1.8	1.8		40.1	60	124

LEGEND

- FLA** — Full Load Amps
- HACR** — Heating, Air Conditioning and Refrigeration
- ICF** — Maximum Instantaneous Current Flow During Start-Up (LRA of compressor plus total FLA of fan motors)
- kW** — Total Fan Motor Input (kilowatts)
- LRA** — Locked Rotor Amps
- MCA** — Minimum Circuit Amps per NEC, Section 430-24
- MOCP** — Maximum Overcurrent Protection (amps)
- RLA** — Rated Load Amps (compressor)



*Units are suitable for use on electrical systems where voltage supplied to the unit terminals is not below or above the listed limits.

†Fuse or HACR circuit breaker.

**380-v units are export models not listed with UL or UL, Canada.

NOTES:

1. The MCA and MOCP values are calculated in accordance with the National Electrical Code (NEC), Article 440.
2. Motor RLA and LRA values are established in accordance with Underwriters' Laboratories (UL), Standard 1995.
3. The 575-v units are UL, Canada-listed only.
4. Convenience outlet is available as either a factory-installed option or a field-installed accessory and is 115-v, 1ph, 60 Hz (38ARD units only).

Application data



Installation

Select equipment to match or to be slightly less than peak load. This provides better humidity control, less unit cycling, and less part-load operation.

When selecting vapor line sizes, oil return must be evaluated, particularly at part-load conditions.

The indoor fan must always be operating when the outdoor unit is operating.

Ductwork should be sized according to unit size, not building load.

To minimize the possibility of air recirculation, avoid the use of concentric supply/return grilles.

Select indoor equipment at no less than 300 cfm/ton.

OPERATING LIMITS

Maximum Outdoor Temperature	115 F
Minimum Outdoor Ambient	See Minimum Outdoor-Air Operating Temperature table below.
Minimum Return-Air Temperature	55 F
Maximum Return-Air Temperature	95 F
Normal Acceptable Saturation Suction Temperature Range	25 to 55 F
Maximum Discharge Temperature	295 F
Minimum Discharge Superheat	60 F

MINIMUM OUTDOOR-AIR OPERATING TEMPERATURE — 38AKS014-024 UNITS

UNIT 38AKS	NO. OF CYLINDERS	FULL LOAD CAPACITY (%)	MINIMUM OUTDOOR-AIR OPERATING TEMPERATURE (F)	
			Base Unit	With Low-Ambient Control
014	6	100	20	-20
	4	67	31	
	2*	33*	40	
016	6	100	20	
	4	67	33	
	2*	33*	47	
024	4	100	15	
	2	50	20	

*Requires field-installed unloader.

REFRIGERANT SPECIALTIES PART NUMBERS

UNIT	LIQUID LINE SIZE (in.)	LIQUID LINE SOLENOID VALVE (LLSV)	LLSV COIL	SIGHT GLASS	FILTER DRIER	SUCTION LINE ACCUMULATOR
38AKS014	1/2	200RB7T4M	AMG/24V	AMI-1TT4	P502-8757S*	S-7063
	5/8	200RA8T5M	AMG/24V	AMI-1TT5	P502-8757S*	S-7063
38AKS016	1/2	200RB7T4M	AMG/24V	AMI-1TT4	P502-8757S*	S-7721
	5/8	200RA8T5M	AMG/24V	AMI-1TT5	P502-8757S*	S-7721
	7/8	200RA8T7M	AMG/24V	AMI-1TT7	P502-8757S	S-7721
38AKS024	5/8	200RA9T5M	AMG/24V	AMI-1TT5	P502-8757S*	S-7721
	7/8	200RA9T7M	AMG/24V	AMI-1TT7	P502-8757S	S-7721
38ARD014	1/2	200RB5T4M Qty 2	AMG/24V Qty 2	AMI-1TT4 Qty 2	P502-8304S Qty 2	S-7063S* Qty 2
38ARD016	1/2	200RB5T4M Qty 2	AMG/24V Qty 2	AMI-1TT4 Qty 2	P502-8304S Qty 2	S-7063S Qty 2
	5/8	200RB5T5M Qty 2	AMG/24V Qty 2	AMI-1TT5 Qty 2	P502-8304S Qty 2	S-7063S Qty 2
38ARD024	1/2	200RB6T4M Qty 2	AMG/24V Qty 2	AMI-1TT5 Qty 2	P502-8307S*	S-7063S Qty 2
	5/8	200RB6T5M Qty 2	AMG/24V Qty 2	AMI-1TT5 Qty 2	P502-8307S*	S-7063S Qty 2

*Bushings required.

MINIMUM OUTDOOR-AIR OPERATING TEMPERATURE — 38ARD014-024 UNITS

UNIT 38ARD	FULL LOAD CAPACITY (%)	SATURATED COND TEMPERATURE (F)	MINIMUM OUTDOOR-AIR TEMPERATURE (F)	
			Base Unit	With Low-Ambient Control
014	100/50	90	35	-20
016				
024				

LIQUID LINE DATA — 38AKS014-024 UNITS

UNIT 38AKS	MAX ALLOW. LIFT (ft)	LIQUID LINE	
		Max Allow. Pressure Drop (psi)	Max Allow. Temp Loss (°F)
014	67	7	2
016	82		
024	87		

NOTE: Data above is for units operating at 45 F saturated suction and 95 F entering air.

LIQUID LINE DATA — 38ARD014-024 UNITS

UNIT 38ARD	MAX ALLOW. LIFT (ft)	LIQUID LINE	
		Max Allow. Pressure Drop (psi)	Max Allow. Temp Loss (°F)
014	60	7	2
016			
024			

Refrigerant piping

It is recommended that the refrigerant piping for all commercial split systems include a liquid line solenoid valve, a liquid line filter drier and a sight glass.

For refrigerant lines longer than 75 lineal ft, a liquid line solenoid and a suction accumulator are required. Refer to the Refrigerant Specialties table.

38ARD, AKS014-024

Application data (cont)

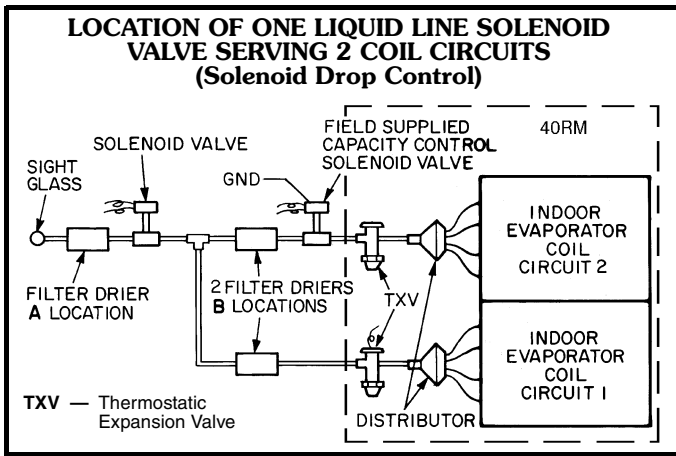

REFRIGERANT PIPING SIZES

UNIT 38AKS	LINEAR LENGTH OF INTERCONNECTING PIPING (FT)									
	0-15		16-25		26-50		51-75		76-100	
	Line Size (in. OD)									
	L	S	L	S	L	S	L	S	L	S
014	1/2	1 1/8	1/2	1 3/8	5/8	1 3/8	5/8	1 5/8*	7/8	1 5/8*
016	1/2	1 3/8	5/8	1 3/8	5/8	1 5/8	7/8	1 5/8	7/8	2 1/8*
024	5/8	1 5/8	5/8	1 5/8	7/8	1 5/8	7/8	2 1/8	7/8	2 1/8

UNIT 38ARD	LINEAR LENGTH OF INTERCONNECTING PIPING (FT)							
	0-25		25-50		50-75		75-100	
	Line Size (in. OD)							
	L	S	L	S	L	S	L	S
014	1/2	1 1/8	1/2	1 1/8	1/2	1 1/8	1/2	1 1/8
016	1/2	1 3/8	1/2	1 3/8	1/2	1 3/8	5/8	1 3/8
024	1/2	1 3/8	1/2	1 3/8	5/8	1 3/8	5/8	1 3/8

LEGEND

- L — Liquid
- S — Suction

Close-coupled.

*Requires a double suction riser if 2 unloaders are used and the evaporator is below the condensing unit. See Refrigerant Piping Sizes — Double Suction Risers table and Suction Line Piping figure at right for more information.

NOTES:

1. Pipe sizes are based on a 2° F loss for liquid lines and a 1.5° F loss for suction lines.
2. Pipe sizes are based on an equivalent length equal to the maximum length of interconnecting piping plus 50% for fittings. A more accurate estimate may result in smaller sizes.

REFRIGERANT PIPING SIZES — DOUBLE SUCTION RISERS

UNIT 38AKS	LINEAR LENGTH OF INTERCONNECTING PIPING (FT)					
	51-75			76-100		
	Line Size (in. OD)					
	A	B	C	A	B	C
014	1 1/8	1 3/8	1 5/8	1 1/8	1 3/8	1 5/8
016	—	—	—	1 3/8	1 5/8	2 1/8

NOTES:

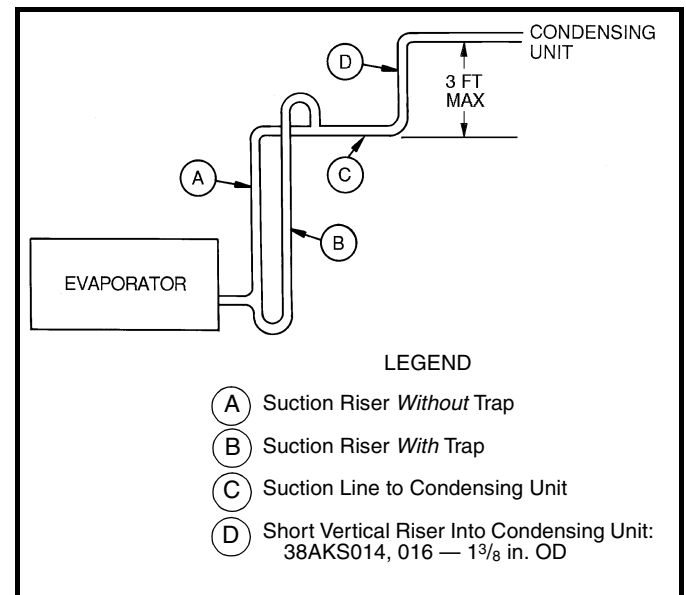

1. See Suction Line Piping figure below for "A," "B," and "C" dimensions.
2. No double suction risers are needed for unit size 024.

SUCTION LINE PIPING

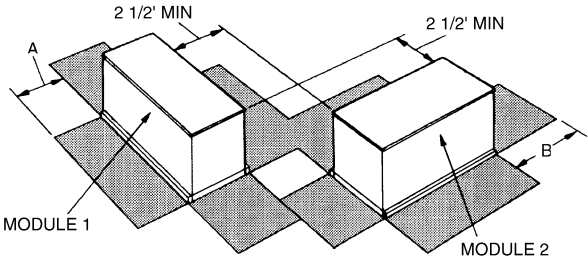
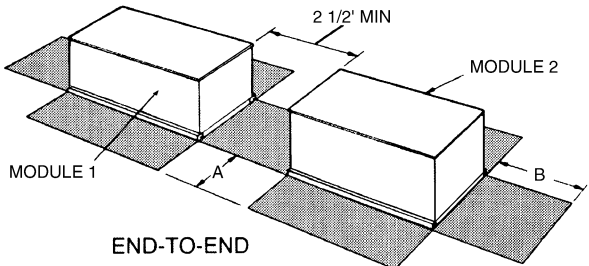
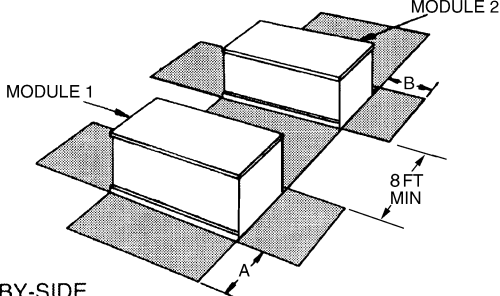

38ARD_AKS014-024

Multiple condensing unit arrangements*

<p style="text-align: center;">38AKS,ARD014-024</p>  <p style="text-align: center;">PERPENDICULAR</p>	<p style="text-align: center;">38AKS,ARD014-024</p>  <p style="text-align: center;">END-TO-END</p>									
<p style="text-align: center;">38AKS,ARD014-024</p>  <p style="text-align: center;">SIDE-BY-SIDE</p>	<p>  Space for Service and Airflow </p> <p>*For clearances between controls and grounded surfaces, check local codes.</p> <table border="1" style="width: 100%; border-collapse: collapse; margin-top: 10px;"> <thead> <tr> <th style="text-align: left;">38AKS,ARD</th> <th colspan="2" style="text-align: center;">DIMENSIONS (ft)</th> </tr> <tr> <th style="text-align: left;">014-024</th> <th style="text-align: center;">A</th> <th style="text-align: center;">B</th> </tr> </thead> <tbody> <tr> <td></td> <td style="text-align: center;">4</td> <td style="text-align: center;">4</td> </tr> </tbody> </table>	38AKS,ARD	DIMENSIONS (ft)		014-024	A	B		4	4
38AKS,ARD	DIMENSIONS (ft)									
014-024	A	B								
	4	4								

38ARD,AKS014-024

Typical piping and wiring



ROOFTOP INSTALLATION — 38ARD014-024

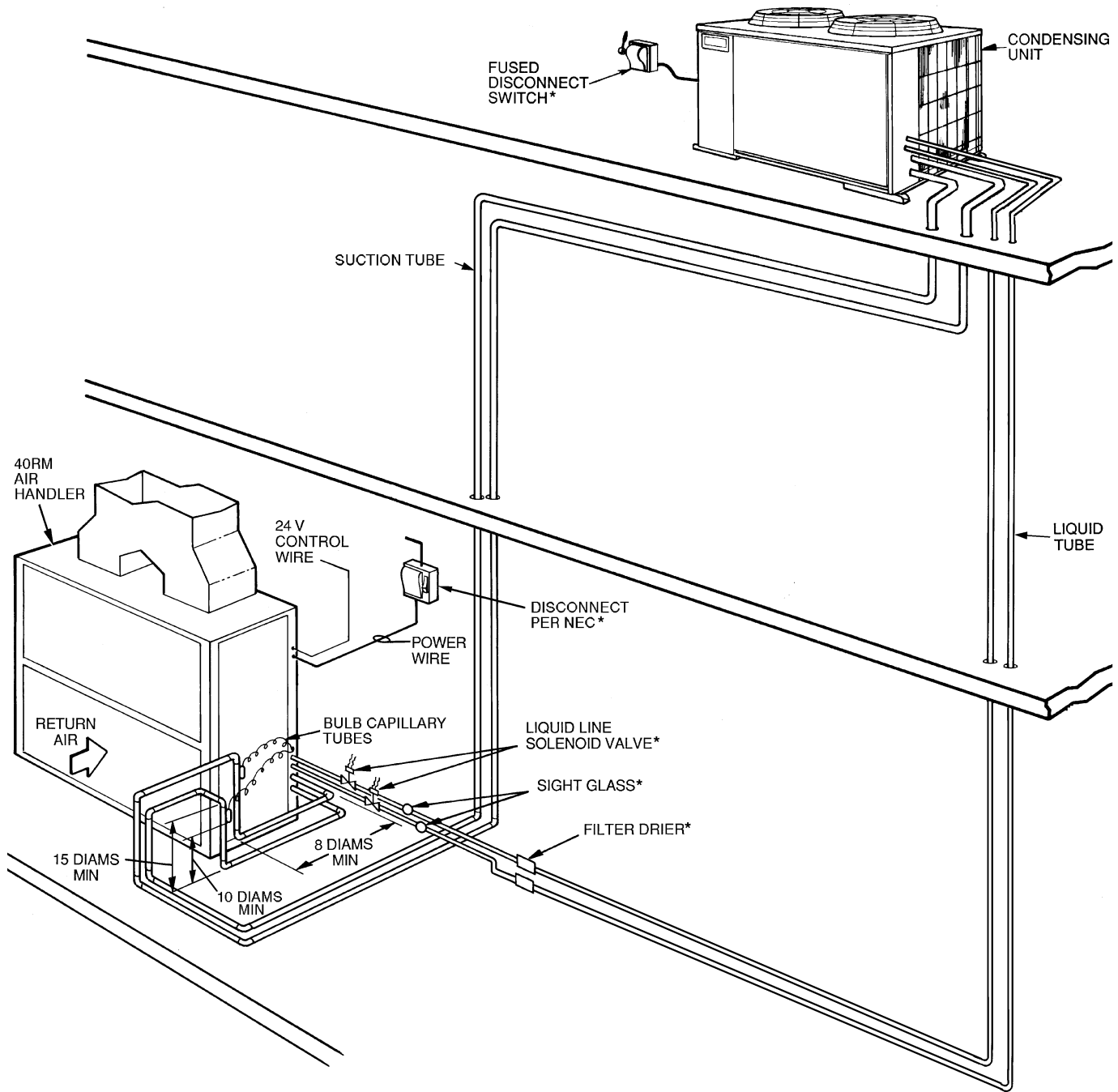

38ARD_AKS014-024

LEGEND

- NEC — National Electrical Code
- TXV — Thermostatic Expansion Valve
- Piping

*Field supplied.

NOTES:

1. All piping must follow standard refrigerant piping techniques. Refer to Carrier System Design Manual for details.
2. All wiring must comply with the applicable local and national codes.
3. Wiring and piping shown are general points-of-connection guides only and are not intended for, or to include all details for, a specific installation.
4. Liquid line solenoid valve (solenoid drop control) is recommended to prevent refrigerant migration to the compressor.
5. Internal factory-supplied TXVs not shown.

GROUND LEVEL INSTALLATION — 38AKS014-024

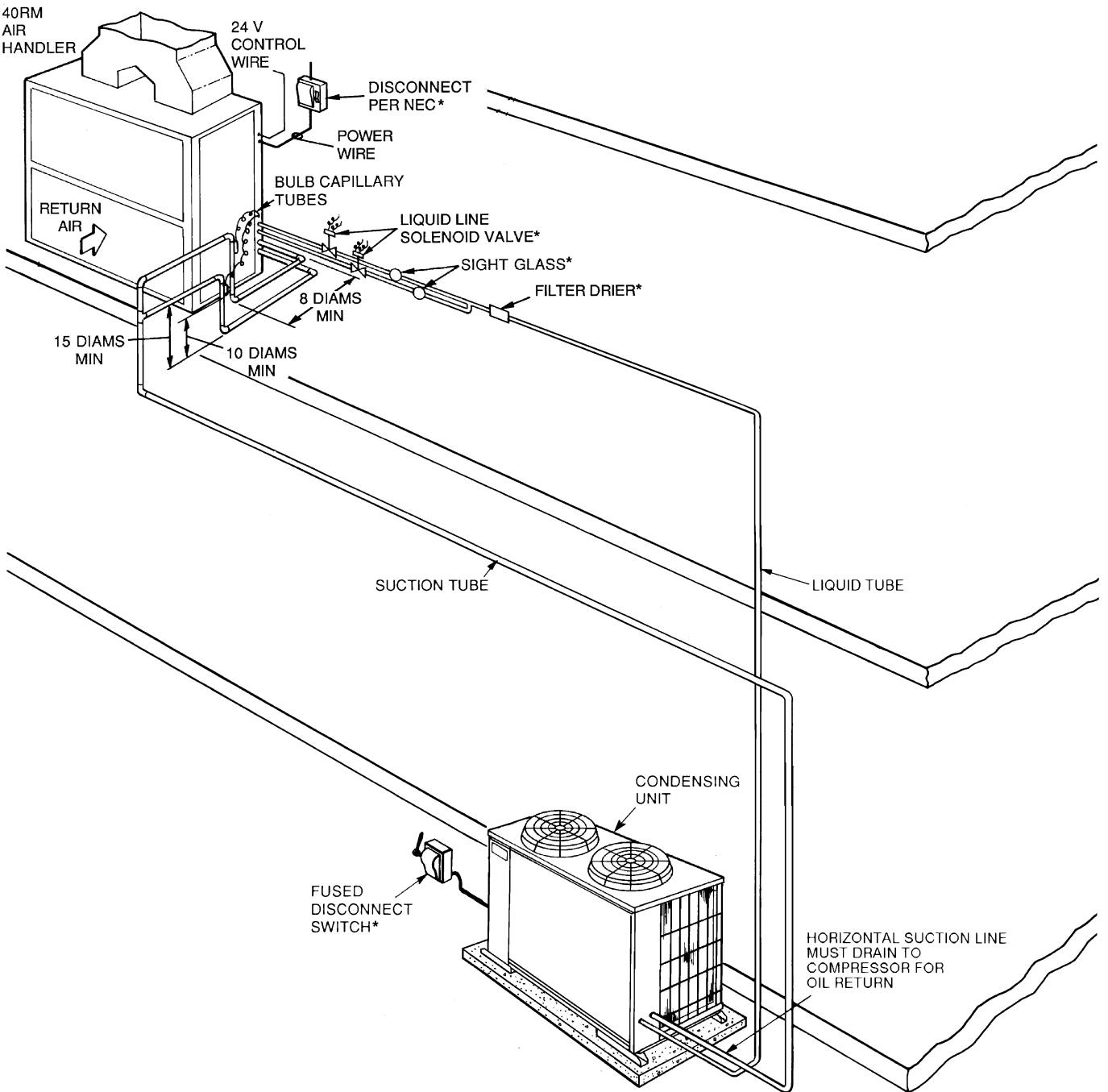

LEGEND
TXV — Thermostatic Expansion Valve
 Piping
 *Field supplied.

- NOTES:**
1. All piping must follow standard refrigerant piping techniques. Refer to Carrier System Design Manual for details.
 2. All wiring must comply with the applicable local and national codes.
 3. Wiring and piping shown are general points-of-connection guides only and are not intended for, or to include all details for, a specific installation.
 4. Liquid line solenoid valve (solenoid drop control) is recommended to prevent refrigerant migration to the compressor.
 5. Internal factory-supplied TXVs not shown.

38ARD,AKS014-024



Commercial Air-Cooled Condensing Units

HVAC Guide Specifications

Size Range: **12¹/₂ to 20 Tons, Nominal**

Carrier Model Number: **38ARD, Sizes 014-024**

Part 1 — General

1.01 SYSTEM DESCRIPTION

Outdoor-mounted, air-cooled condensing unit suitable for on-the-ground or rooftop installation. Unit shall have 2 independent refrigeration circuits. Unit shall consist of dual scroll compressors, an air-cooled coil, propeller-type condenser fans, and a control box. Unit shall discharge supply air upward as shown on contract drawings. Unit shall be used in a refrigeration circuit matched with a packaged air-handling unit.

1.02 QUALITY ASSURANCE

- A. Unit shall be rated in accordance with ARI Standard 360 (2000), and shall be certified and listed in the latest ARI directory.
- B. Unit construction shall comply with ANSI/ASHRAE safety code, latest revision, and comply with NEC.
- C. Unit shall be constructed in accordance with UL 1995 standard and shall carry the UL and UL, Canada label.
- D. Unit cabinet shall be capable of withstanding 500-hour salt spray exposure per ASTM B117 (scribed specimen).
- E. Air-cooled condenser coils shall be leak tested at 150 psig, and pressure tested at 480 psig.
- F. Unit shall be manufactured in a facility registered to ISO 9001:2000 manufacturing quality standard.

1.03 DELIVERY, STORAGE, AND HANDLING

Unit shall be shipped as single package only, and shall be stored and handled according to unit manufacturer's recommendations.

1.04 WARRANTY (FOR INCLUSION BY SPECIFYING ENGINEER.)

Part 2 — Products

2.01 EQUIPMENT

A. General:

Factory-assembled, single piece, air-cooled condensing unit. Contained within the unit enclosure shall be all factory wiring, piping, controls, compressor, holding charge (R-22), and special features required prior to field start-up.

B. Unit Cabinet:

Unit cabinet shall be constructed of G-90 galvanized steel, bonderized and coated with a prepainted baked enamel finish.

C. Fans:

1. Condenser fans shall be direct driven, propeller-type, discharging air vertically upward.
2. Fan blades shall be balanced.

3. Condenser fan discharge openings shall be equipped with PVC-coated steel wire safety guards.
4. Condenser fan and motor shaft shall be corrosion resistant.

D. Compressor:

1. Compressors shall be of the hermetic scroll type.
2. Compressors shall be mounted on vibration isolators.
3. Compressors shall include overload protection.
4. Compressors shall be equipped with a crank-case heater.
5. Compressors shall be equipped with internal high discharge temperature protection (38ARD016 and 024 only).

E. Condenser Coil:

1. Condenser coil shall be air-cooled and circuited for integral subcooler.
2. Coil shall be constructed of aluminum fins (copper fins optional) mechanically bonded to internally grooved seamless copper tubes which are then cleaned, dehydrated, and sealed.

F. Refrigeration Components:

Refrigeration circuit components shall include high side pressure relief device, liquid line service valve, suction line service valve, a full charge of compressor oil, and a holding charge of refrigerant.

G. Controls and Safeties:

1. Minimum control functions shall include:
 - a. Power and control wire terminal blocks.
 - b. Compressor lockout on auto-reset safety until reset from thermostat.
 - c. Recycle time delay of five minutes to prevent compressor short cycling.
2. Minimum safety devices shall include:
 - Automatic reset (after resetting first at thermostat):
 - a. High discharge pressure cutout.
 - b. Loss-of-charge cutout.
 - c. Condenser fan motors to be protected against overload condition by internal overloads.

Manual reset at the unit:

Electrical overload protection through the use of define-purpose contactors and calibrated, ambient compensated, magnetic trip circuit breakers. Circuit breakers shall open all three phases in the event of an overload in any one of the phases or a single phase condition.

H. Operating Characteristics:

1. The capacity of the condensing unit shall meet or exceed _____ Btuh at a suction temperature



of ____ F. The power consumption at full load shall not exceed ____ kW.

2. The combination of the condensing unit and the evaporator or fan coil unit shall have a total net cooling capacity of ____ Btuh or greater at conditions of ____ cfm entering-air temperature at the evaporator at ____ F wet bulb and ____ F dry bulb, and air entering the condensing unit at ____ F.
3. The system shall have an EER of ____ Btuh/Watt or greater at standard ARI conditions.

I. Electrical Requirements:

1. Nominal unit electrical characteristics shall be ____ v, 3-ph, 60 Hz. The unit shall be capable of satisfactory operation within voltage limits of ____ v to ____ v.
2. Unit electrical power shall be single-point connection.
3. Unit control circuit shall contain a 24-v transformer for unit control.

J. Special Features:

1. Low-Ambient Temperature Control:

A low-ambient temperature control shall be available as a factory-installed option or as a field-installed accessory. This low-ambient control shall regulate speed of the condenser-fan motors in response to the saturated condensing temperature of the unit. The control shall maintain correct condensing pressure at outdoor temperatures down to -20 F.

2. Gage Panel Package:

Gage panel package shall include a suction and discharge pressure gage.

3. Optional Condenser Coil Materials:

a. Pre-Coated Aluminum-Fin Coils:

Shall have a durable epoxy-phenolic coating to provide protection in mildly corrosive coastal environments. Coating shall be applied to the aluminum fin stock prior to the fin stamping process to create an inert barrier between the aluminum fin and copper tube. Epoxy-phenolic barrier shall minimize galvanic action between dissimilar metals.

b. Copper-Fin Coils:

Shall be constructed of copper-fins mechanically bonded to copper-tubes and copper tube sheets. Galvanized steel tube sheets shall not be acceptable. A polymer strip shall prevent coil assembly from contacting sheet metal coil pan to minimize potential for galvanic corrosion between the coil and pan. All copper construction shall provide protection in moderate coastal environments.

c. E-Coated Aluminum-Fin Coils:

Shall have a flexible epoxy polymer coating uniformly applied to all coil surface areas without material bridging between fins. Coating process shall ensure complete coil encapsulation. Color shall be high gloss black with gloss requirements of 60° of 65 to 90% per ASTM D523-89. Uniform dry film thickness from 0.8 to 1.2 mil on all surface areas including fin edges. Superior hardness characteristics of 2H per ASTM D3363-92A and cross hatch adhesion of 4B-5B per ASTM D3359-93. Impact resistance shall be up to 160 in./lb (ASTM D2794-93). Humidity and water immersion resistance shall be up to a minimum of 1000 and 250 hours respectively (ASTM D2247-92 and ASTM D870-92). Corrosion durability shall be confirmed through testing to no less than 1000 hours salt spray per ASTM B117-90. Coil construction shall be aluminum fins mechanically bonded to copper tubes.

d. E-Coated Copper-Fin Coils:

Shall have a flexible epoxy polymer coating uniformly applied to all coil surface areas without material bridging between fins. Coating process shall ensure complete coil encapsulation. Color shall be high gloss black with gloss requirements of 60° of 65 to 90% per ASTM D523-89. Uniform dry film thickness from 0.8 to 1.2 mil on all surface areas including fin edges. Superior hardness characteristics of 2H per ASTM D3363-92A and cross hatch adhesion of 4B-5B per ASTM D3359-93. Impact resistance shall be up to 160 in./lb (ASTM D2794-93). Humidity and water immersion resistance shall be up to a minimum of 1000 and 250 hours respectively (ASTM D2247-92 and ASTM D870-92). Corrosion durability shall be confirmed through testing to no less than 1000 hours salt spray per ASTM B117-90. Coil construction shall be copper-fins mechanically bonded to copper-tubes with copper tube sheets. Galvanized steel tube sheets shall not be acceptable. A polymer strip shall prevent coil assembly from contacting sheet metal coil pan to maintain coating integrity and minimize corrosion potential between the coil and pan.

4. Unit-Mounted, Non-Fused Disconnect Switch:

Shall be factory-installed, internally mounted. NEC and UL approved non-fused switch shall provide unit power shutoff. Shall be accessible from outside the unit and shall provide power off lockout capability.

38ARD_AKS014-024

Guide specifications — 38ARD014-024 (cont)



5. Convenience Outlet:

Shall be factory-installed and internally mounted with easily accessible 115-v female receptacle. Shall include 15 amp GFI receptacle with independent fuse protection. Voltage required to operate convenience outlet shall be provided by a factory-installed step-down transformer. Shall be accessible from outside the unit.

6. Thermostat Controls:

- a. Programmable multi-stage thermostat with 7-day clock, holiday scheduling, large backlit display, remote sensor capability, and Title 24 compliance.
- b. Commercial Electronic Thermostat with 7-day timeclock, auto-changeover, multi-stage capability, and large LCD temperature display.

c. Carrier PremierLink™ Controller:

This control will function with CCN and ComfortVIEW™ software. It shall also be compatible with ComfortLink™ controllers. It shall be ASHRAE 62-99 compliant and Internet ready. It shall accept a CO₂ sensor in the conditioned space and be Demand Control Ventilation (DCV) ready. The communication rate must be 38.4K or faster. It shall include an integrated economizer controller.

7. Condenser Coil Grille:

Grille shall add decorative appearance to unit and protect condenser coil after installation.

38ARD,AKS014-024

Commercial Air-Cooled Condensing Units

HVAC Guide Specifications

Size Range: **12¹/₂ to 20 Tons, Nominal**

Carrier Model Number: **38AKS, Sizes 014-024**

Part 1 — General

1.01 SYSTEM DESCRIPTION

Outdoor-mounted, air-cooled condensing unit suitable for on-the-ground or rooftop installation. Unit shall have a single refrigeration circuit. Unit shall consist of a semi-hermetic reciprocating compressor, an air-cooled coil, propeller-type condenser fans, and a control box. Unit shall discharge supply air upward as shown on contract drawings. Unit shall be used in a refrigeration circuit to match a packaged fan coil unit.

1.02 QUALITY ASSURANCE

- A. Unit shall be rated in accordance with ARI Standard 360-93, and shall be certified and listed in the latest ARI directory.
- B. Unit shall be manufactured in a facility registered to ISO 9001:2000 manufacturing quality standard.
- C. Unit construction shall comply with latest edition of ANSI/ASHRAE and with NEC.
- D. Unit shall be constructed in accordance with UL standards and shall carry the UL and UL, Canada label.
- E. Unit cabinet shall be capable of withstanding 500-hour salt spray exposure per ASTM B117 (scribed specimen)
- F. Air-cooled condenser coils shall be leak tested at 150 psig and pressure tested at 480 psig.

1.03 DELIVERY, STORAGE, AND HANDLING

Unit shall be shipped as a single package only, and shall be stored and handled per manufacturer's recommendations.

1.04 WARRANTY (FOR INCLUSION BY SPECIFYING ENGINEER.)

Part 2 — Products

2.01 EQUIPMENT

A. General:

Factory assembled, single piece, air-cooled condensing unit. Contained within the unit enclosure shall be all factory wiring, piping, controls, compressor, holding charge (R-22), and special features required prior to field start-up.

B. Unit Cabinet:

Unit cabinet shall be constructed of G-90 galvanized steel, bonderized and coated with a prepainted, baked enamel finish.

C. Fans:

1. Condenser fans shall be direct-drive propeller type, discharging air vertically upward.
2. Condenser fan motor no. 1 shall be ball bearing type compatible with accessory low-ambient control.

3. Shafts shall have inherent corrosion resistance.
4. Fan blades shall be statically and dynamically balanced.
5. Condenser fan openings shall be equipped with PVC-coated steel wire safety guards.

D. Compressor:

1. Compressor shall be serviceable, reciprocating, semi-hermetic type.
2. Compressor shall be equipped with an automatically reversible oil pump, operating oil charge, suction and discharge shutoff valves, and an insert-type, factory-sized crankcase heater to control oil dilution.
3. Compressor shall be mounted on spring vibration isolators with an isolation efficiency of no less than 95%.
4. Compressor speed shall not exceed 1750 rpm.
5. Compressor shall unload using suction cutoff unloading (electrical solenoid unloading shall be available as an accessory).

E. Condenser Coil:

1. Condenser coil shall be air cooled, circuited for integral subcooler.
2. Coil shall be constructed of aluminum fins mechanically bonded to copper tubes which are then cleaned, dehydrated, and sealed. Copper fins shall be available as an option.

F. Refrigeration Components:

Refrigeration circuit components shall include hot gas muffler, high-side pressure relief device, liquid line shutoff valve, suction and discharge shutoff valves, holding charge of refrigerant R-22, and compressor oil.

G. Controls and Safeties:

1. Minimum control functions shall include:
 - a. Power and control terminal blocks.
 - b. Five-minute protection to prevent compressor short-cycling.
 - c. Capacity control on the compressor shall be by suction cutoff unloader in response to compressor suction pressure. Electric solenoid unloading shall be available as an accessory.
 - d. Head pressure control by fan cycling. One condenser fan shall be cycled by discharge pressure to maintain proper head pressure.
2. Minimum safety devices shall include:

Automatic reset (after resetting first at thermostat)

 - a. High discharge-pressure cutout.
 - b. Low suction pressure cutout.
 - c. Condenser fan motors to be protected against overload condition by internal overloads.

d. Manual reset at the unit.

Electrical overload protection through the use of definite-purpose contactors and calibrated, ambient compensated, magnetic trip circuit breakers. Circuit breakers shall open all phases in the event of an overload in any one of the phases or a single-phase condition.

H. Operating Characteristics:

1. The capacity of the condensing unit shall meet or exceed _____ Btuh at a suction temperature of _____ F. The power consumption at full load shall not exceed _____ kW.
2. The combination of the condensing unit and the evaporator or fan coil unit shall have a total net cooling capacity of _____ Btuh or greater at conditions of _____ cfm entering-air temperature at the evaporator at _____ F wet bulb and _____ F dry bulb, and air entering the condensing unit at _____ F.
3. The system shall have an EER of _____ Btuh/Watt or greater at standard ARI conditions.

I. Electrical Requirements:

1. Nominal unit electrical characteristics shall be _____ v, 3-ph, 60 Hz. The unit shall be capable of satisfactory operation within voltage limits of _____ v to _____ v.
2. Unit electrical power shall be single point connection.
3. Unit control circuit shall contain a 24-v transformer for unit control, with capacity to operate an indoor fan interlock.

J. Special Features:

1. Low-Ambient Control:

Control shall regulate fan motor speed in response to the saturated condensing temperature of the unit. The control shall allow the unit to operate down to an ambient temperature of -20 F.

2. Electric Solenoid Unloader:

Unloader valve piston, coil, and hardware shall be supplied to convert the pressure-operated compressor unloader to electric unloading.

3. Condenser Coil Grille Package:

Grilles shall protect the condenser coils after unit installation.

4. Gage Panel Package:

Gage panel package shall include a suction and discharge pressure gage.

5. Optional Condenser Coil Materials:

a. Pre-Coated Aluminum-Fin Coils:

Shall have a durable epoxy-phenolic coating to provide protection in mildly corrosive coastal environments. Coating shall be applied to the aluminum fin stock prior to the fin stamping process to create an inert

barrier between the aluminum fin and copper tube. Epoxy-phenolic barrier shall minimize galvanic action between dissimilar metals.

b. Copper-Fin Coils:

Shall be constructed of copper-fins mechanically bonded to copper-tubes and copper tube sheets. Galvanized steel tube sheets shall not be acceptable. A polymer strip shall prevent coil assembly from contacting sheet metal coil pan to minimize potential for galvanic corrosion between the coil and pan. All copper construction shall provide protection in moderate coastal environments.

c. E-Coated Aluminum-Fin Coils:

Shall have a flexible epoxy polymer coating uniformly applied to all coil surface areas without material bridging between fins. Coating process shall ensure complete coil encapsulation. Color shall be high gloss black with gloss requirements of 60° of 65 to 90% per ASTM D523-89. Uniform dry film thickness from 0.8 to 1.2 mil on all surface areas including fin edges. Superior hardness characteristics of 2H per ASTM D3363-92A and cross hatch adhesion of 4B-5B per ASTM D3359-93. Impact resistance shall be up to 160 in./lb (ASTM D2794-93). Humidity and water immersion resistance shall be up to a minimum of 1000 and 250 hours respectively (ASTM D2247-92 and ASTM D870-92). Corrosion durability shall be confirmed through testing to no less than 1000 hours salt spray per ASTM B117-90. Coil construction shall be aluminum fins mechanically bonded to copper tubes.

d. E-Coated Copper-Fin Coils:

Shall have a flexible epoxy polymer coating uniformly applied to all coil surface areas without material bridging between fins. Coating process shall ensure complete coil encapsulation. Color shall be high gloss black with gloss requirements of 60° of 65 to 90% per ASTM D523-89. Uniform dry film thickness from 0.8 to 1.2 mil on all surface areas including fin edges. Superior hardness characteristics of 2H per ASTM D3363-92A and cross hatch adhesion of 4B-5B per ASTM D3359-93. Impact resistance shall be up to 160 in./lb (ASTM D2794-93). Humidity and water immersion resistance shall be up to a minimum of 1000 and 250 hours respectively (ASTM D2247-92 and ASTM D870-92). Corrosion durability shall be confirmed through testing to no less than 1000 hours salt spray per ASTM B117-90. Coil construction shall be copper-fins mechanically bonded to copper tubes with copper tube sheets. Galvanized steel



tube sheets shall not be acceptable. A polymer strip shall prevent coil assembly from contacting sheet metal coil pan to maintain coating integrity and minimize corrosion potential between the coil and pan.

6. Thermostat Controls:

a. Carrier PremierLink™ Controller:

This control will function with CCN and ComfortVIEW™ software. It shall also be compatible with *ComfortLink™* controllers. It shall be ASHRAE 62-99 compliant and Internet ready. It shall accept a CO₂ sensor in

the conditioned space and be Demand Control Ventilation (DCV) ready. The communication rate must be 38.4K or faster. It shall include an integrated economizer controller.

b. Programmable multi-stage thermostat with 7-day clock, holiday scheduling, large backlit display, remote sensor capability, and Title 24 compliance.

c. Commercial Electronic Thermostat with 7-day timeclock, auto-changeover, multi-stage capability, and large LCD temperature display.

Model number nomenclature — 40RM007-028

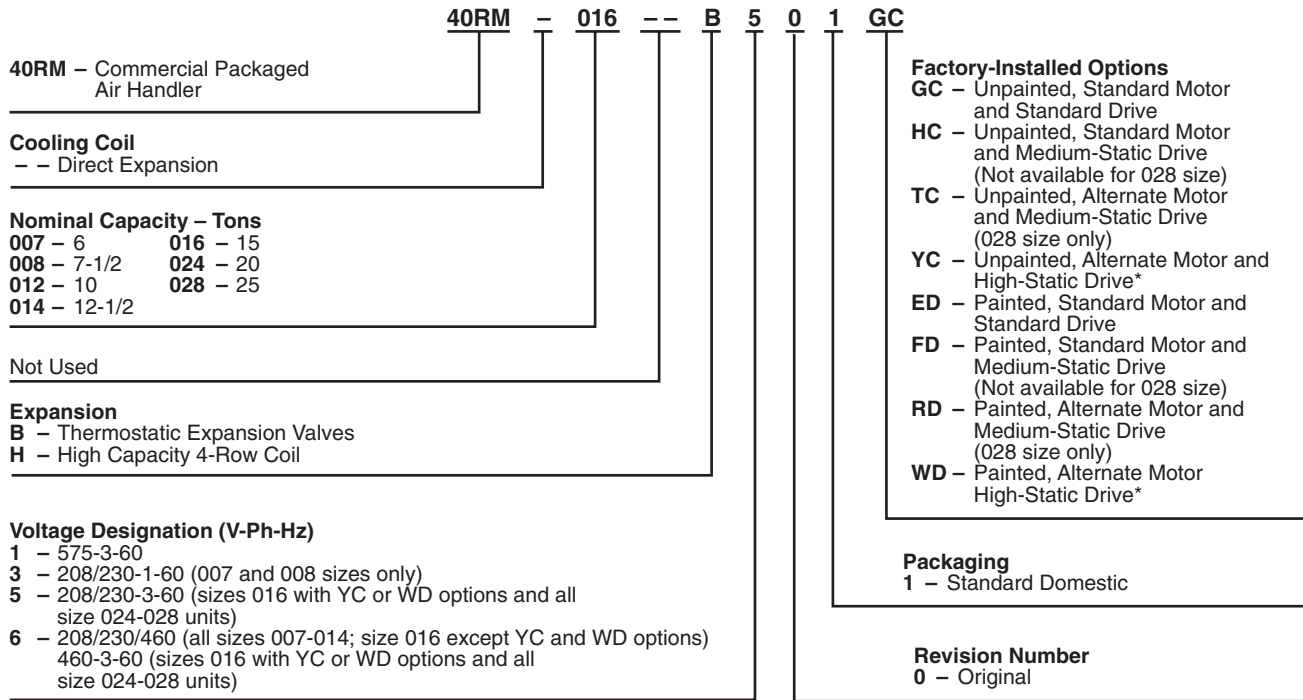

*The YC and WD option codes for size 008 units with 208/230-1-60 power designate standard motor and high-static drive.

Quality Assurance

Certified to ISO 9001:2000

Physical data



40RM

UNIT 40RM	007	008	012	014	016	024	028
NOMINAL CAPACITY (Tons)	6	7½	10	12½	15	20	25
OPERATING WEIGHT (lb)							
Base Unit with TXV (3 Row/4 Row)	381/399	385/404	405/425	670/695	685/713	690/730	1020/1050
Plenum	175	175	175	225	225	225	325
Economizer	185	185	185	340	340	340	340
Hot Water Coil	195	195	195	285	285	285	345
Steam Coil	215	215	215	340	340	340	405
FANS							
Qty...Diam. (in.)	1...15	1...15	1...15	2...15	2...15	2...15	2...18
Nominal Airflow (cfm)	2400	3000	4000	5000	6000	8000	10,000
Airflow Range (cfm)	1800-3000	2250-3750	3000-5000	3750-6250	4500-7500	6000-10,000	7500-12,500
Nominal Motor Hp (Standard Motor)*							
208/230-1-60	1.3	2.4	—	—	—	—	—
208/230-3-60 and 460-3-60	2.4	2.4	2.4	2.9	3.7	5.0	7.5
575-3-60	1.0	2.0	2.0	3.0	3.0	5.0	7.5
Motor Speed (rpm)							
208/230-1-60	1725	1725	—	—	—	—	—
208/230-3-60 and 460-3-60	1725	1725	1725	1725	1725	1745	1745
575-3-60	1725	1725	1725	1725	1725	1745	1755
REFRIGERANT							
Operating charge (lb)							
(approx per circuit)†	3.0	3.0	1.5/1.5	2.0/2.0	2.5/2.5	3.5/3.5	4.5/4.5
DIRECT-EXPANSION COIL							
Max Working Pressure (psig)							
Face Area (sq ft)	6.67	8.33	10.01	13.25 ⁴³⁵	17.67	19.88	24.86
No. of Splits	1	1	2	2	2	2	2
Split Type...Percentage	—	—	—	—	Face...50/50	—	—
No. of Circuits per Split (3 Row/4 Row)	12/12	15/15	9/9	9/12	12/16	13/18	15/20
Fins/in.	15	15	17	15	15	17	15
STEAM COIL							
Total Face Area (sq ft)	6.67	6.67	6.67	13.33	13.33	13.33	15.0
Rows...Fins/in.	1...9	1...9	1...9	1...10	1...10	1...10	1...10
HOT WATER COIL							
Max Working Pressure (psig)							
Total Face Area (sq ft)	6.67	6.67	6.67	13.33 ¹⁵⁰	13.33	13.33	15.0
Rows...Fins/in.	2...8.5	2...8.5	2...8.5	2...8.5	2...8.5	2...8.5	2...12.5
Water Volume (gal)		8.3			13.9		14.3
(ft ³)		1.1			1.85		1.90
PIPING CONNECTIONS							
Quantity...Size (in.)							
DX Coil — Suction (ODF)	1...1½	1...1½	2...1½	2...1½	2...1½	2...1 ⅞	2...1¾
DX Coil — Liquid Refrigerant (ODF)	1...5/8				2...5/8		
Steam Coil, In (MPT)	1...2½				1...2½		
Steam Coil, Out (MPT)	1...1½				1...1½		
Hot Water Coil, In (MPT)	1...1½		1...1½			1...2	
Hot Water Coil, Out (MPT)	1...1½		1...1½			1...2	
Condensate (PVC)				1...1¼ ODM/1 IDF			
FILTERS							
Quantity...Size (in.)		4...16 x 24 x 2			4...16 x 20 x 2		4...20 x 24 x 2
Access Location					4...16 x 24 x 2		4...20 x 25 x 2
					Right or Left Side		

LEGEND

DX — Direct Expansion
 TXV — Thermostatic Expansion Valve

*Refer to alternate Fan Motor Data table, page 98, for alternate motor data.

†Units are shipped without refrigerant charge.

40RM007-028

40RM007-012

UNIT 40RM	UNIT WEIGHT lb
007	381
008	385
012	405
007 4 ROW	399
008 4 ROW	404
012 4 ROW	425

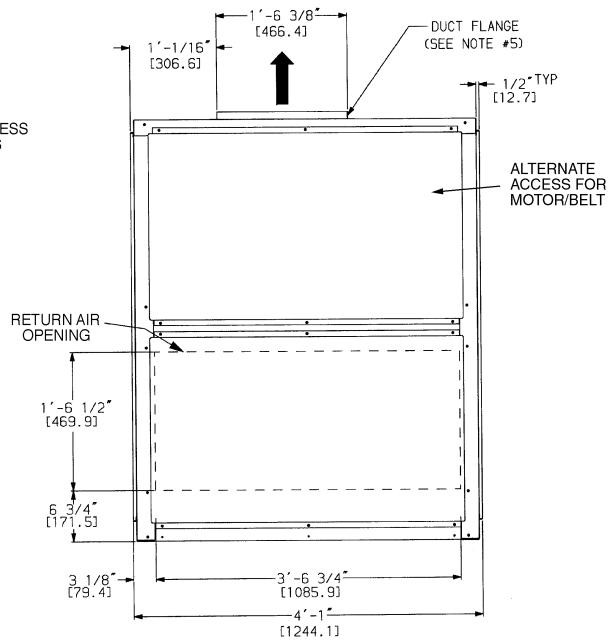
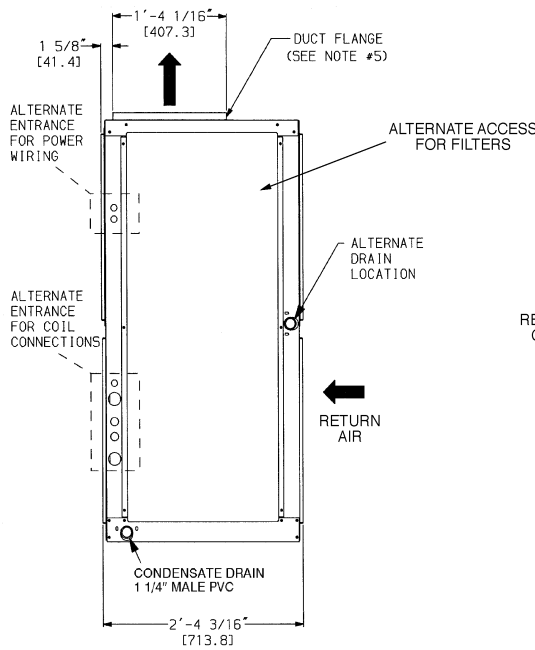
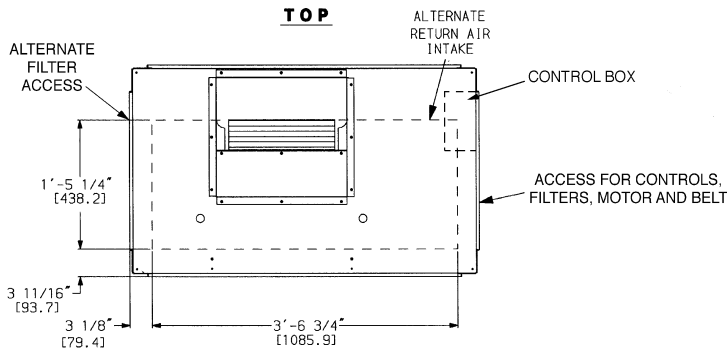

LEFT SIDE

FRONT

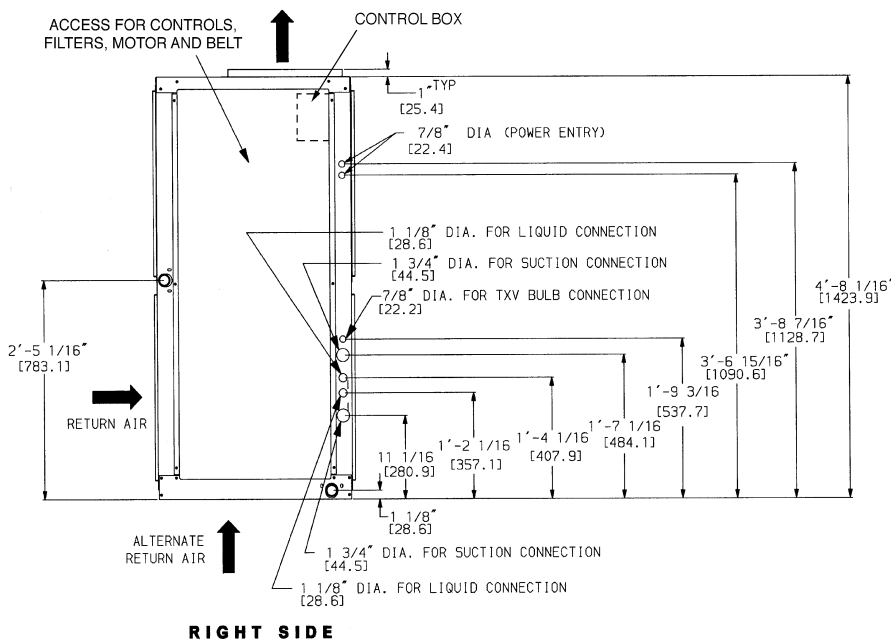

RIGHT SIDE

TXV — Thermostatic Expansion Valve

NOTES:

1. Dimensions in [] are in millimeters.
2. Direction of airflow.
3. Recommended clearance:
 - Rear: 3" (76.2 mm) (2'-6" [762 mm] with electric heat accessory)
 - Front: 2'-6" (762 mm)
 - Right side: 2'-6" (762 mm)
 - Left Side: 2'-6" (762 mm)
 - Local codes or jurisdiction may prevail.
4. Liquid piping not supplied by Carrier.
5. Duct flange is factory supplied and field installed.

40RM007-028

40RM014-024

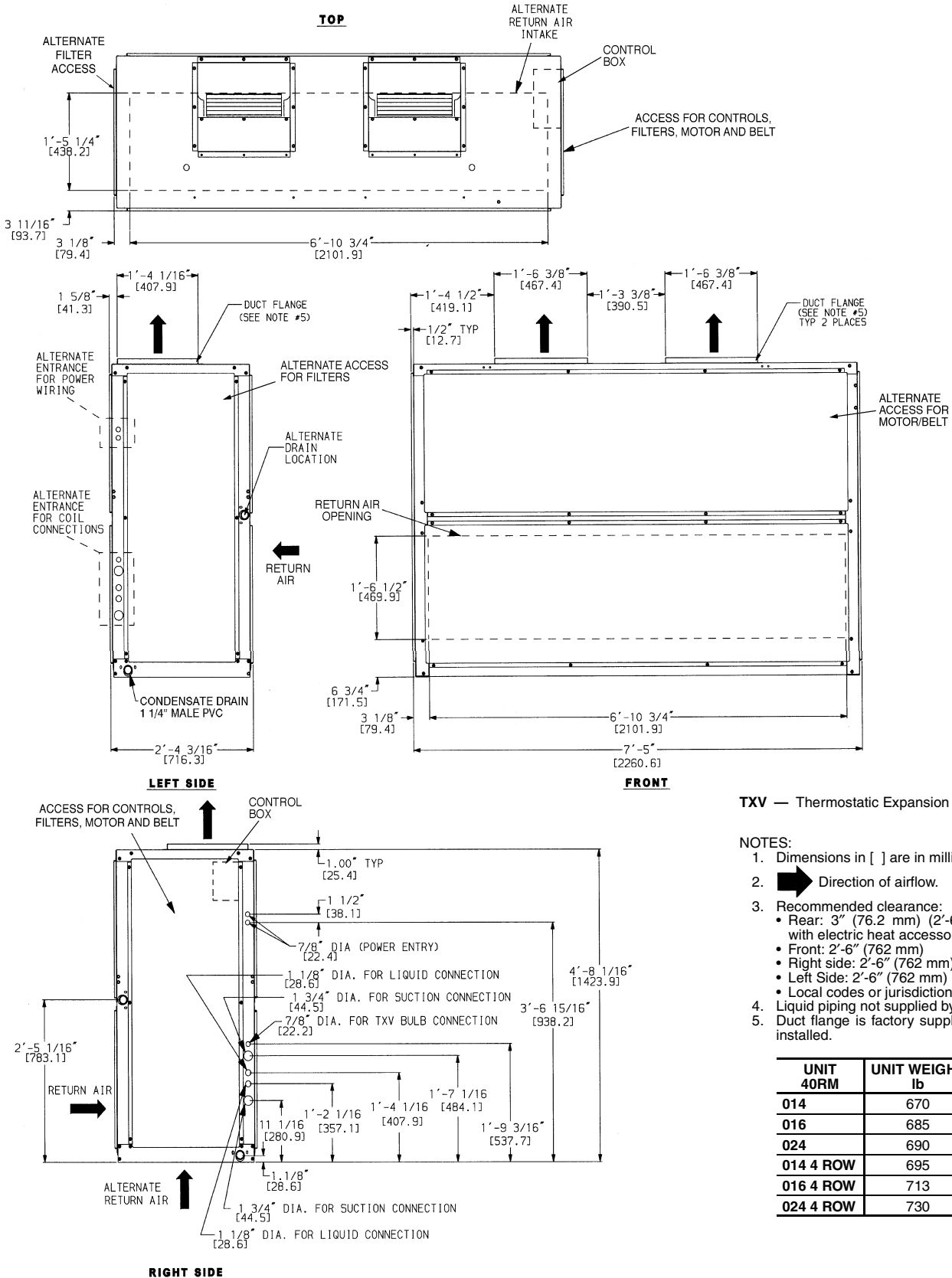

TXV — Thermostatic Expansion Valve

NOTES:

- Dimensions in [] are in millimeters.
- Direction of airflow.
- Recommended clearance:
 - Rear: 3" (76.2 mm) (2'-6" [762 mm] with electric heat accessory)
 - Front: 2'-6" (762 mm)
 - Right side: 2'-6" (762 mm)
 - Left Side: 2'-6" (762 mm)
- Local codes or jurisdiction may prevail.
- Liquid piping not supplied by Carrier.
- Duct flange is factory supplied and field installed.

UNIT 40RM	UNIT WEIGHT lb
014	670
016	685
024	690
014 4 ROW	695
016 4 ROW	713
024 4 ROW	730

40RM007-028

Dimensions (cont)



40RM028

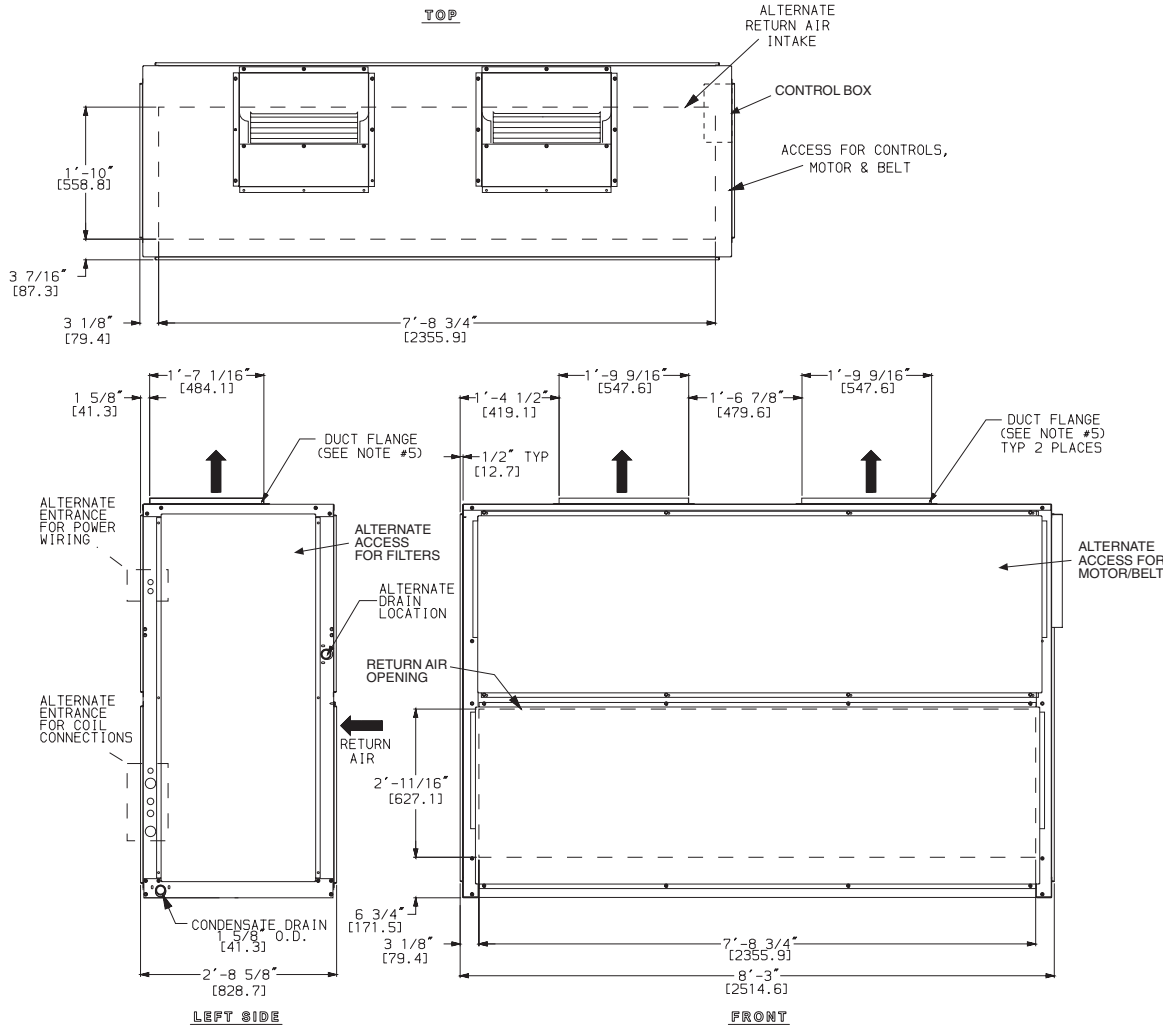

TXV — Thermostatic Expansion Valve

NOTES:

1. Dimensions in [] are in millimeters.
2. Direction of airflow.
3. Recommended clearance:
 - Rear: 3" (76.2 mm) (2'-6" [762 mm] with electric heat accessory)
 - Front: 2'-6" (762 mm)
 - Right side: 2'-6" (762 mm)
 - Left Side: 2'-6" (762 mm)
 - Local codes or jurisdiction may prevail.
4. Liquid piping not supplied by Carrier.
5. Duct flange is factory supplied and field installed.

UNIT 40RM	UNIT WEIGHT lb
028	1020
028 4 ROW	1050

40RM007-028

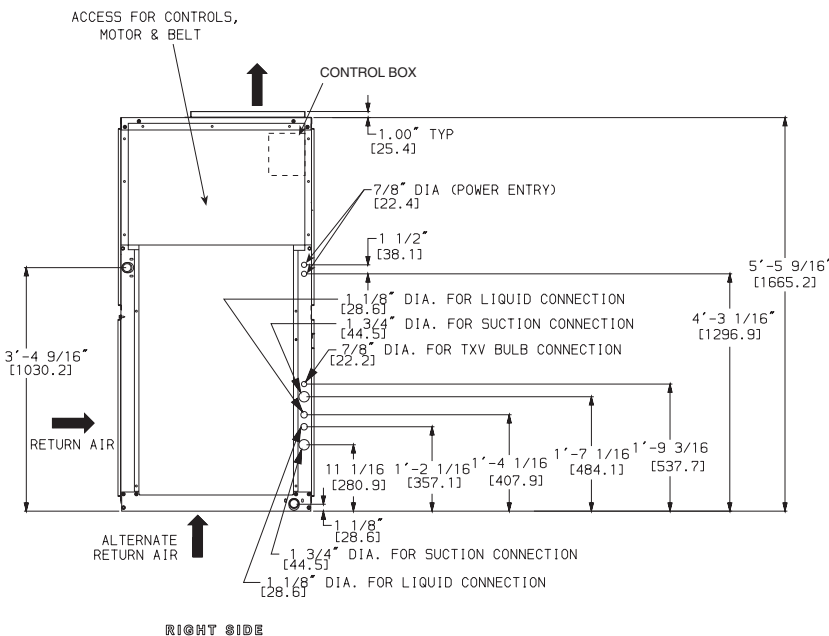

Performance data



FAN PERFORMANCE DATA — 40RM WITH STANDARD COIL — 0.0-1.2 in. wg ESP

UNIT 40RM (Standard 3-Row Coil)	AIRFLOW (Cfm)	EXTERNAL STATIC PRESSURE (in. wg)													
		0.0		0.2		0.4		0.6		0.8		1.0		1.2	
		Rpm	Bhp	Rpm	Bhp	Rpm	Bhp	Rpm	Bhp	Rpm	Bhp	Rpm	Bhp	Rpm	Bhp
007	1,800	399	0.19	454	0.24	548	0.35	634	0.47	713	0.60	785	0.74	850	0.89
	2,100	446	0.28	497	0.34	583	0.46	660	0.59	733	0.73	802	0.88	867	1.05
	2,400	498	0.40	541	0.47	622	0.60	693	0.74	760	0.89	824	1.05	885	1.22
	2,700	544	0.55	588	0.63	663	0.78	730	0.93	792	1.09	851	1.26	909	1.44
	3,000	594	0.73	635	0.82	707	0.99	770	1.15	828	1.32	883	1.50	937	1.69
008	2,250	273	0.08	493	0.37	580	0.49	656	0.62	727	0.76	794	0.92	858	1.08
	2,600	322	0.15	540	0.52	622	0.66	693	0.81	757	0.96	819	1.12	878	1.29
	3,000	552	0.65	595	0.73	673	0.91	740	1.07	800	1.24	856	1.41	910	1.60
	3,400	615	0.91	653	1.01	726	1.21	789	1.40	846	1.59	899	1.78	950	1.97
	3,750	671	1.20	706	1.31	773	1.53	834	1.74	889	1.95	940	2.16	988	2.37
012	3,000	399	0.29	573	0.69	654	0.86	722	1.03	784	1.19	841	1.37	896	1.55
	3,500	604	0.92	641	1.02	714	1.22	780	1.42	838	1.61	892	1.81	942	2.01
	4,000	680	1.33	713	1.45	778	1.68	839	1.91	896	2.14	947	2.36	995	2.58
	4,500	756	1.86	787	1.99	845	2.26	901	2.52	955	2.78	1005	3.03	1051	3.28
	5,000	834	2.51	861	2.67	914	2.96	966	3.25	1016	3.54	1064	3.82	1109	4.11
014	3,750	394	0.40	453	0.52	558	0.80	643	1.10	717	1.39	785	1.71	848	2.04
	4,300	436	0.57	487	0.70	586	1.00	670	1.34	742	1.67	806	2.01	867	2.36
	5,000	492	0.86	535	0.99	623	1.31	704	1.69	775	2.08	838	2.47	896	2.86
	5,700	550	1.23	587	1.37	664	1.71	740	2.11	809	2.55	872	2.99	929	3.43
	6,250	596	1.59	630	1.74	700	2.09	770	2.51	837	2.97	899	3.45	955	3.94
016	4,500	428	0.59	475	0.70	570	0.99	656	1.33	730	1.68	796	2.02	856	2.38
	5,300	488	0.92	528	1.04	609	1.34	689	1.71	762	2.11	827	2.51	886	2.92
	6,000	542	1.29	578	1.43	649	1.74	721	2.11	791	2.55	855	3.00	914	3.46
	6,800	604	1.83	637	1.99	700	2.32	763	2.70	826	3.15	888	3.64	946	4.15
	7,500	660	2.42	690	2.59	747	2.95	804	3.34	861	3.79	919	4.29	975	4.83
024	6,000	532	1.25	569	1.39	639	1.69	711	2.06	781	2.48	846	2.93	905	3.39
	7,000	608	1.93	641	2.09	702	2.42	763	2.80	824	3.23	885	3.71	943	4.23
	8,000	686	2.83	716	3.01	770	3.38	823	3.77	876	4.21	930	4.70	983	5.24
	9,000	764	3.97	791	4.18	841	4.59	888	5.02	935	5.47	982	5.96	1030	6.51
	10,000	843	5.38	868	5.62	914	6.09	957	6.55	1000	7.02	1042	7.53	1084	8.08
028	7,500	456	1.29	490	1.47	556	1.85	621	2.25	678	2.64	729	3.06	778	3.60
	8,750	521	1.98	551	2.18	608	2.61	664	3.07	720	3.53	770	3.99	816	4.45
	10,000	587	2.88	614	3.11	664	3.59	714	4.09	763	4.62	812	5.15	857	5.68
	11,250	653	4.03	678	4.29	724	4.82	768	5.37	812	5.95	856	6.54	899	7.14
	12,500	720	5.46	743	5.75	785	6.33	825	6.93	865	7.55	904	8.20	944	8.86

See Legend and Notes on page 88.

40RM007-028

Performance data (cont)



FAN PERFORMANCE DATA — 40RM WITH STANDARD COIL — 1.4-2.4 in. wg ESP

UNIT 40RM (Standard 3-Row Coil)	AIRFLOW (Cfm)	EXTERNAL STATIC PRESSURE (in. wg)											
		1.4		1.6		1.8		2.0		2.2		2.4	
		Rpm	Bhp	Rpm	Bhp	Rpm	Bhp	Rpm	Bhp	Rpm	Bhp	Rpm	Bhp
007	1,800	910	1.04	965	1.20	1016	1.36	1065	1.52	1111	1.69	1155	1.86
	2,100	927	1.21	983	1.38	1035	1.56	1084	1.74	1131	1.92	1175	2.11
	2,400	944	1.41	999	1.59	1052	1.78	1101	1.98	1149	2.18	1193	2.38
	2,700	964	1.63	1018	1.82	1069	2.03	1118	2.24	1165	2.45	—	—
	3,000	989	1.89	1039	2.10	1089	2.31	1136	2.53	1183	2.76	—	—
008	2,250	918	1.26	975	1.43	1029	1.62	1079	1.80	1126	1.99	1172	2.18
	2,600	936	1.48	991	1.67	1044	1.87	1094	2.07	1142	2.28	1188	2.49
	3,000	963	1.79	1014	1.99	1064	2.20	1113	2.42	1159	2.64	—	—
	3,400	998	2.18	1045	2.39	1092	2.61	1137	2.83	1182	3.07	—	—
	3,750	1034	2.58	1078	2.80	1122	3.03	1164	3.27	—	—	—	—
012	3,000	949	1.74	1000	1.93	1050	2.14	1099	2.36	1147	2.58	1192	2.81
	3,500	990	2.21	1037	2.42	1083	2.64	1128	2.86	1172	3.10	—	—
	4,000	1040	2.80	1084	3.03	1126	3.26	1167	3.50	—	—	—	—
	4,500	1094	3.53	1136	3.78	1176	4.03	—	—	—	—	—	—
	5,000	1151	4.39	1191	4.66	—	—	—	—	—	—	—	—
014	3,750	909	2.37	968	2.74	1026	3.12	1080	3.51	1131	3.92	1181	4.32
	4,300	925	2.73	980	3.11	1034	3.52	1084	3.92	1135	4.35	1184	4.78
	5,000	950	3.26	1002	3.67	1052	4.09	1101	4.53	1148	4.98	1190	5.44
	5,700	981	3.88	1031	4.33	1079	4.79	1125	5.25	1169	5.73	—	—
	6,250	1007	4.42	1057	4.91	1103	5.40	1148	5.90	1191	6.40	—	—
016	4,500	912	2.75	967	3.13	1019	3.52	1070	3.92	1120	4.35	1168	4.79
	5,300	940	3.33	992	3.75	1041	4.18	1088	4.61	1134	5.06	1179	5.52
	6,000	968	3.92	1018	4.38	1066	4.85	1112	5.32	1156	5.80	1198	6.29
	6,800	1000	4.67	1050	5.19	1097	5.71	1142	6.23	1185	6.76	—	—
	7,500	1028	5.39	1078	5.97	1125	6.54	1170	7.11	—	—	—	—
024	6,000	954	3.83	1005	4.27	1052	4.72	1098	5.22	1142	5.67	—	—
	7,000	990	4.74	1040	5.24	1090	5.80	1135	6.30	1176	6.84	—	—
	8,000	1028	5.79	1078	6.38	1130	7.00	1173	7.60	—	—	—	—
	9,000	1073	7.11	1120	7.72	1169	8.37	—	—	—	—	—	—
	10,000	1126	8.75	1166	9.37	—	—	—	—	—	—	—	—
028	7,500	831	4.41	870	5.10	913	5.90	950	6.88	985	7.70	—	—
	8,750	859	4.97	901	5.59	944	6.42	980	7.20	1020	8.10	—	—
	10,000	900	6.20	939	6.74	976	7.33	1013	8.00	1050	8.82	—	—
	11,250	941	7.73	980	8.32	1017	8.90	1052	9.51	1086	10.16	—	—
	12,500	984	9.53	1022	10.19	1058	10.84	1093	11.49	—	—	—	—

See Legend and Notes on page 88.

40RM007-028



FAN PERFORMANCE DATA — 40RM WITH HIGH-CAPACITY COIL — 0.0-1.2 in. wg ESP

UNIT 40RM (High-Capacity 4-Row Coil)	AIRFLOW (Cfm)	EXTERNAL STATIC PRESSURE (in. wg)													
		0.0		0.2		0.4		0.6		0.8		1.0		1.2	
		Rpm	Bhp	Rpm	Bhp	Rpm	Bhp	Rpm	Bhp	Rpm	Bhp	Rpm	Bhp	Rpm	Bhp
007	1,800	419	0.21	471	0.26	564	0.37	649	0.49	727	0.63	797	0.77	862	0.92
	2,100	471	0.31	519	0.37	602	0.49	679	0.62	751	0.77	819	0.92	882	1.09
	2,400	524	0.44	568	0.51	645	0.64	715	0.79	781	0.94	844	1.11	905	1.28
	2,700	578	0.61	619	0.69	690	0.84	755	0.99	816	1.15	875	1.33	932	1.51
	3,000	633	0.81	671	0.90	738	1.07	799	1.24	856	1.41	910	1.60	963	1.79
008	2,250	290	0.10	510	0.39	594	0.51	669	0.65	739	0.79	806	0.95	870	1.12
	2,600	349	0.19	561	0.55	640	0.70	709	0.84	773	1.00	834	1.16	893	1.34
	3,000	579	0.70	621	0.79	695	0.96	759	1.12	818	1.30	874	1.47	928	1.66
	3,400	646	0.99	683	1.09	752	1.29	813	1.48	869	1.67	920	1.86	970	2.06
	3,750	705	1.31	739	1.42	804	1.63	862	1.85	915	2.05	964	2.26	1011	2.48
012	3,000	421	0.35	592	0.73	670	0.90	737	1.06	797	1.23	854	1.41	908	1.59
	3,500	626	0.98	664	1.08	735	1.28	798	1.48	855	1.67	908	1.87	958	2.07
	4,000	706	1.42	738	1.54	803	1.77	862	2.00	917	2.23	967	2.45	1014	2.67
	4,500	786	1.99	815	2.12	873	2.39	929	2.65	980	2.90	1028	3.16	1073	3.41
	5,000	867	2.70	893	2.84	946	3.14	997	3.43	1046	3.72	1092	4.00	1135	4.28
014	3,750	410	0.43	467	0.55	567	0.83	649	1.12	721	1.41	788	1.72	851	2.05
	4,300	455	0.62	504	0.74	599	1.05	679	1.38	748	1.70	811	2.04	871	2.39
	5,000	514	0.92	556	1.06	641	1.39	718	1.76	786	2.14	847	2.52	903	2.91
	5,700	575	1.32	612	1.47	686	1.82	759	2.23	825	2.66	884	3.09	939	3.52
	6,250	624	1.71	657	1.87	725	2.24	793	2.66	856	3.12	915	3.59	969	4.06
016	4,500	437	0.61	483	0.72	576	1.01	660	1.35	732	1.69	797	2.03	856	2.38
	5,300	499	0.95	538	1.07	617	1.37	696	1.74	767	2.13	830	2.53	888	2.94
	6,000	555	1.34	590	1.48	659	1.79	730	2.17	798	2.59	860	3.04	918	3.49
	6,800	620	1.91	651	2.06	712	2.39	774	2.78	836	3.22	896	3.71	952	4.21
	7,500	677	2.52	706	2.69	761	3.04	817	3.44	873	3.89	929	4.39	984	4.93
024	6,000	542	1.29	577	1.42	646	1.72	716	2.09	785	2.51	849	2.95	907	3.40
	7,000	620	1.99	652	2.15	711	2.48	771	2.85	831	3.28	890	3.76	947	4.27
	8,000	700	2.92	728	3.10	781	3.46	833	3.85	885	4.29	938	4.78	990	5.32
	9,000	781	4.10	806	4.30	854	4.71	900	5.13	946	5.58	993	6.08	1039	6.62
	10,000	862	5.56	885	5.79	929	6.24	971	6.70	1012	7.18	1054	7.69	1096	8.24
028	7,500	476	1.39	510	1.58	579	1.99	644	2.40	701	2.81	752	3.29	804	3.96
	8,750	545	2.14	574	2.35	633	2.81	691	3.29	747	3.77	797	4.25	842	4.76
	10,000	615	3.12	641	3.36	692	3.87	743	4.41	794	4.96	843	5.51	888	6.05
	11,250	685	4.37	709	4.64	754	5.20	800	5.79	845	6.40	891	7.02	935	7.64
	12,500	756	5.92	778	6.22	819	6.83	860	7.47	901	8.14	942	8.83	983	9.52

See Legend and Notes on page 88.

40RM007-028

Performance data (cont)



FAN PERFORMANCE DATA — 40RM WITH HIGH-CAPACITY COIL — 1.4-2.4 in. wg ESP

UNIT 40RM (High Capacity 4-Row Coil)	AIRFLOW (Cfm)	EXTERNAL STATIC PRESSURE (in. wg)											
		1.4		1.6		1.8		2.0		2.2		2.4	
		Rpm	Bhp	Rpm	Bhp	Rpm	Bhp	Rpm	Bhp	Rpm	Bhp	Rpm	Bhp
007	1,800	921	1.07	975	1.23	1026	1.39	1074	1.55	1120	1.72	1164	1.90
	2,100	942	1.26	997	1.43	1048	1.61	1097	1.79	1143	1.97	1186	2.16
	2,400	963	1.47	1017	1.66	1069	1.85	1118	2.05	1164	2.25	—	—
	2,700	987	1.71	1039	1.91	1090	2.12	1138	2.33	1185	2.55	—	—
	3,000	1015	1.99	1065	2.20	1113	2.42	1161	2.65	—	—	—	—
008	2,250	930	1.29	986	1.47	1039	1.65	1089	1.84	1136	2.03	1181	2.22
	2,600	950	1.53	1005	1.72	1057	1.92	1107	2.13	1154	2.33	—	—
	3,000	980	1.86	1031	2.06	1081	2.27	1129	2.49	1175	2.72	—	—
	3,400	1018	2.26	1065	2.48	1111	2.70	1156	2.93	—	—	—	—
	3,750	1057	2.69	1101	2.92	1144	3.15	1186	3.39	—	—	—	—
012	3,000	961	1.78	1012	1.98	1062	2.19	1111	2.41	1158	2.64	—	—
	3,500	1005	2.27	1052	2.49	1098	2.71	1142	2.94	1186	3.18	—	—
	4,000	1058	2.90	1101	3.13	1143	3.36	1184	3.60	—	—	—	—
	4,500	1116	3.66	1157	3.91	1196	4.16	—	—	—	—	—	—
	5,000	1176	4.56	—	—	—	—	—	—	—	—	—	—
014	3,750	912	2.39	971	2.76	1028	3.14	1083	3.54	1135	3.95	1185	4.36
	4,300	928	2.75	982	3.13	1036	3.53	1087	3.94	1138	4.37	1187	4.81
	5,000	956	3.30	1007	3.71	1056	4.13	1104	4.56	1151	5.00	1196	5.46
	5,700	990	3.96	1039	4.40	1086	4.85	1130	5.31	1174	5.78	—	—
	6,250	1019	4.54	1067	5.02	1112	5.50	1156	5.99	1198	6.49	—	—
016	4,500	912	2.75	967	3.12	1019	3.52	1070	3.92	1120	4.35	1168	4.79
	5,300	942	3.34	992	3.76	1041	4.18	1088	4.61	1134	5.06	1179	5.52
	6,000	971	3.95	1020	4.40	1067	4.86	1112	5.33	1156	5.81	1198	6.29
	6,800	1005	4.72	1054	5.23	1101	5.75	1145	6.27	1187	6.79	—	—
	7,500	1036	5.48	1084	6.04	1131	6.61	1174	7.17	—	—	—	—
024	6,000	961	3.86	1011	4.31	1058	4.77	1104	5.24	1147	5.71	—	—
	7,000	1000	4.79	1050	5.32	1097	5.85	1142	6.38	1184	6.91	—	—
	8,000	1041	5.88	1090	6.47	1137	7.07	1181	7.67	—	—	—	—
	9,000	1086	7.21	1133	7.82	1178	8.47	—	—	—	—	—	—
	10,000	1138	8.83	1180	9.46	—	—	—	—	—	—	—	—
028	7,500	874	5.33	897	5.91	940	6.80	990	7.50	—	—	—	—
	8,750	886	5.36	930	6.13	982	7.32	1020	8.10	—	—	—	—
	10,000	930	6.60	969	7.20	1007	7.89	1045	8.71	—	—	—	—
	11,250	976	8.25	1014	8.86	1051	9.49	1086	10.17	—	—	—	—
	12,500	1023	10.20	1061	10.88	1097	11.56	—	—	—	—	—	—

LEGEND

Bhp — Brake Horsepower Input to Fan
ESP — External Static Pressure

Bold indicates field-supplied drive required.

Plain type indicates standard drive and standard motor.

Underline indicates a different motor and drive combination other than the standard motor and standard drive combination is required. Refer to fan motor and drive tables on pages 98-100 to complete the selection.

NOTES:

1. Maximum allowable fan speed is 1100 rpm for unit size 028 and 1200 rpm for all other sizes.
2. Fan performance is based on deductions for wet coil, clean 2-in. filters, and unit casing. See table on page 89 for factory-supplied filter pressure drop.
3. The medium-static drive and standard motor combination is not available for the 028 size. Use alternate motor if the medium-static drive is required for the 028 size.

40RM007-028



**FACTORY-SUPPLIED FILTER PRESSURE DROP
(in. wg)**

UNIT 40RM	AIRFLOW (Cfm)	PRESSURE DROP (in. wg)
007	1,800	0.05
	2,400	0.08
	3,000	0.11
008	2,250	0.07
	3,000	0.11
	3,750	0.15
012	3,000	0.11
	4,000	0.17
	5,000	0.23
014	3,750	0.06
	5,000	0.10
	6,250	0.13
016	4,500	0.08
	6,000	0.12
	7,500	0.17
024	6,000	0.12
	8,000	0.19
	10,000	0.26
028	7,500	0.15
	10,000	0.22
	12,500	0.30

**ACCESSORY PLENUM AIR THROW DATA
(ft)**

UNIT 40RM	AIRFLOW (Cfm)	VANE DEFLECTION		
		Straight	22½°	45°
007	2,400	39	33	24
008	3,000	45	38	28
012	4,000	55	46	33
014	5,000	45	38	28
016	6,000	50	43	31
024	8,000	60	51	37
028	10,000	76	65	47

NOTE: Throw distances shown are for 75 fpm terminal velocity. Use the following multipliers to determine throw values for other terminal velocities.

TERMINAL VELOCITY (Fpm)	THROW FACTOR
50	X 1.50
100	X 0.75
150	X 0.50

40RM007-028

Performance data (cont)



ACCESSORY PRESSURE DROP (in. wg)

UNIT 40RM	AIRFLOW (Cfm)	DISCHARGE PLENUM	RETURN AIR GRILLE	HEATING COILS			ECONOMIZER
				Hot Water	Steam	Electric	
007	1,800	0.06	0.01	0.10	0.10	0.04	0.05
	2,400	0.10	0.01	0.16	0.16	0.06	0.07
	3,000	0.14	0.02	0.23	0.23	0.10	0.09
008	2,250	0.09	0.01	0.15	0.15	0.06	0.06
	3,000	0.14	0.02	0.23	0.23	0.10	0.09
	3,750	0.21	0.03	0.35	0.35	0.15	0.15
012	3,000	0.14	0.02	0.23	0.23	0.10	0.09
	4,000	0.22	0.04	0.37	0.37	0.17	0.17
	5,000	0.32	0.06	0.53	0.53	0.26	0.28
014	3,750	0.07	0.01	0.11	0.11	0.04	0.05
	5,000	0.12	0.02	0.17	0.17	0.07	0.07
	6,250	0.17	0.02	0.25	0.25	0.11	0.11
016	4,500	0.10	0.01	0.15	0.15	0.06	0.06
	6,000	0.16	0.02	0.23	0.23	0.10	0.09
	7,500	0.23	0.03	0.33	0.33	0.15	0.15
024	6,000	0.16	0.02	0.23	0.23	0.10	0.09
	8,000	0.26	0.04	0.37	0.37	0.17	0.17
	10,000	0.37	0.06	0.53	0.53	0.26	0.28
028	7,500	0.15	0.02	0.28	0.28	0.09	0.06
	10,000	0.24	0.03	0.44	0.44	0.16	0.09
	12,500	0.34	0.05	0.63	0.63	0.24	0.14

40RM HYDRONIC HEATING CAPACITIES

UNIT 40RM	AIRFLOW (Cfm)	1-ROW STEAM*		2-ROW HOT WATER COIL†			
		Cap.	Ldb	Cap.	Ldb	Gpm	PD
007	1,800	146	134	156.0	140	15.6	3.4
	2,400	173	126	183.0	131	18.3	4.3
	3,000	209	123	206.0	124	20.6	5.2
008	2,250	168	129	174.0	133	17.4	4.0
	3,000	209	123	206.0	124	20.6	5.2
	3,750	240	117	238.0	118	23.8	6.5
012	3,000	209	123	299.0	152	29.9	5.0
	4,000	243	115	275.0	124	27.5	6.6
	5,000	279	111	316.0	119	31.6	8.2
014	3,750	370	150	362.0	149	36.2	4.2
	5,000	425	137	409.0	136	40.9	5.1
	6,250	465	128	456.0	128	45.6	6.0
016	4,500	402	141	412.0	145	41.2	4.5
	6,000	458	129	471.0	133	47.1	5.5
	7,500	479	118	529.0	125	52.9	6.6
024	6,000	458	129	506.0	138	50.6	5.1
	8,000	487	115	584.0	128	58.4	6.3
	10,000	499	105	652.0	120	65.2	7.5
028	7,500	511	122	649.0	140	64.9	5.7
	10,000	575	112	752.0	130	75.2	7.1
	12,500	626	106	842.0	122	84.2	8.5

LEGEND

Cap. — Capacity (Btuh in thousands)
Ldb — Leaving-Air Dry-Bulb Temp (F)
PD — Pressure Drop (ft water)

*Based on 5 psig steam, 60 F entering-air temperature. All steam coils are non-freeze type.

†Based on 200 F entering water, 20 F water temperature drop, 60 F entering-air temperature.

NOTES:

- Maximum operating limits for steam heating coils: 20 psig at 260 F.
- Maximum operating limit for hot water heating coils is 150 psig.
- Leaving db = ent db (F) + $\frac{\text{Capacity (Btuh)}}{1.1 \times \text{cfm}}$
- See 40RM Heating Correction Factors table.

40RM HEATING CORRECTION FACTORS

HOT WATER COIL						
Water Temp Drop (F)	Ent Water Temp (F)	Entering-Air Temp (F)				
		40	50	60	70	80
		10	140	0.72	0.64	0.57
160	0.89		0.81	0.74	0.66	0.58
180	1.06		0.98	0.90	0.83	0.75
200	1.22		1.15	1.07	1.00	0.92
220	1.39		1.32	1.24	1.17	1.09
20	140	0.64	0.57	0.49	0.41	0.33
	160	0.81	0.74	0.66	0.58	0.51
	180	0.98	0.91	0.83	0.75	0.68
	200	1.15	1.08	1.00	0.93	0.85
	220	1.32	1.25	1.17	1.10	1.02
30	140	0.56	0.49	0.41	0.33	0.24
	160	0.74	0.66	0.58	0.51	0.43
	180	0.91	0.83	0.76	0.68	0.60
	200	1.08	1.00	0.93	0.85	0.78
	220	1.25	1.18	1.10	1.03	0.95

STEAM COIL

Steam Pressure (psig)	Entering-Air Temp (F)				
	40	50	60	70	80
0	1.06	0.98	0.91	0.85	0.78
2	1.09	1.02	0.95	0.89	0.82
5	1.13	1.06	1.00	0.93	0.87

NOTE: Multiply capacity given in the 40RM Hydronic Heating Capacities table by the correction factor for conditions at which unit is actually operating. Correct leaving-air temperature using formula in Note 3 of Hydronic Heating Capacities table.

40RM007-028

Electrical data



40RM STANDARD MOTORS

UNIT 40RM	V-PH-Hz	VOLTAGE LIMITS	FAN MOTOR		POWER SUPPLY	
			Hp (kW)	FLA	Minimum Circuit Amps	MOCP
007	208/230-1-60	187-253	1.3 (0.97)	7.6	9.5	15
	208/230-3-60	187-253	2.4 (1.79)	5.2	6.5	15
	460-3-60	414-506	2.4 (1.79)	2.6	3.3	15
	575-3-60	518-632	1.0 (0.75)	1.4	1.8	15
008	208/230-1-60	187-253	2.4 (1.79)	11.0	13.8	20
	208/230-3-60	187-253	2.4 (1.79)	5.2	6.5	15
	460-3-60	414-506	2.4 (1.79)	2.6	3.3	15
	575-3-60	518-632	2.0 (1.49)	2.3	2.9	15
012	208/230-3-60	187-253	2.4 (1.79)	5.2	6.5	15
	460-3-60	414-506	2.4 (1.79)	2.6	3.3	15
	575-3-60	518-632	2.0 (1.49)	2.3	2.9	15
014	208/230-3-60	187-253	2.9 (2.16)	7.5	9.4	15
	460-3-60	414-506	2.9 (2.16)	3.4	4.3	15
	575-3-60	518-632	3.0 (2.24)	3.8	4.8	15
016	208/230-3-60	187-253	3.7 (2.76)	10.2	12.8	20
	460-3-60	414-506	3.7 (2.76)	4.8	6.0	15
	575-3-60	518-632	3.0 (2.24)	3.8	4.8	15
024	208/230-3-60	187-253	5.0 (3.73)	14.6/12.8	18.3/16.0	30/25
	460-3-60	414-506	5.0 (3.73)	6.4	8.0	15
	575-3-60	518-632	5.0 (3.73)	5.1	6.4	15
028	208/230-3-60	187-253	7.5 (5.59)	21.5/19.4	26.9/24.3	45/40
	460-3-60	414-506	7.5 (5.59)	9.7	12.1	20
	575-3-60	518-632	7.5 (5.59)	7.8	9.8	15

LEGEND

FLA — Full Load Amps
MOCP — Maximum Overcurrent Protection

40RM ALTERNATE MOTORS

UNIT 40RM	V-PH-Hz	VOLTAGE LIMITS	FAN MOTOR		POWER SUPPLY	
			Hp (kW)	FLA	Minimum Circuit Amps	MOCP
007	208/230-1-60	187-253	2.4 (1.79)	11.0	13.8	20
	208/230-3-60	187-253	2.9 (2.16)	7.5	9.4	15
	460-3-60	414-506	2.9 (2.16)	3.4	4.3	15
	575-3-60	518-632	2.0 (1.49)	2.3	2.9	15
008	208/230-1-60	187-253	2.4 (1.79)	11.0	13.8	15
	208/230-3-60	187-253	2.9 (2.16)	7.5	9.4	15
	460-3-60	414-506	2.9 (2.16)	3.4	4.3	15
	575-3-60	518-632	3.0 (2.24)	3.8	4.8	15
012	208/230-3-60	187-253	3.7 (2.76)	10.2	12.8	20
	460-3-60	414-506	3.7 (2.76)	4.8	6.0	15
	575-3-60	518-632	3.0 (2.24)	3.8	4.8	15
014	208/230-3-60	187-253	3.7 (2.76)	10.2	12.7	20
	460-3-60	414-506	3.7 (2.76)	4.8	6.0	15
	575-3-60	518-632	5.0 (3.73)	5.1	6.4	15
016	208/230-3-60	187-253	5.0 (3.73)	14.6/12.8	18.3/16.0	30/25
	460-3-60	414-506	5.0 (3.73)	6.4	8.0	15
	575-3-60	518-632	5.0 (3.73)	5.1	6.4	15
024	208/230-3-60	187-253	7.5 (5.59)	21.5/19.4	26.9/24.3	45/40
	460-3-60	414-506	7.5 (5.59)	9.7	12.1	20
	575-3-60	518-632	7.5 (5.59)	7.8	9.8	15
028	208/230-3-60	187-253	10.0 (7.46)	28.2/26.8	35.3/33.5	60/60
	460-3-60	414-506	10.0 (7.46)	13.4	16.8	30
	575-3-60	518-632	10.0 (7.46)	10.3	12.9	20

LEGEND

FLA — Full Load Amps
MOCP — Maximum Overcurrent Protection



40RM007-028

Electrical data (cont)



40RM ELECTRIC HEATER DATA

HEATER PART NO.	UNIT	V-PH-Hz	FAN MOTOR			ELECTRIC HEATER(S)					MCA*	MOCP*
						Nominal Capacity (kW)	Actual Capacity (kW)			FLA		
			Hp	kW	FLA		Stage 1	Stage 2	Total			
CAELHEAT001A00	40RM007-012	208-3-60	1.3†	0.97	7.6	5	3.8	—	3.8	10.4	22.5	25
			2.4†	1.79	11.0	5	3.8	—	3.8	10.4	26.8	35
			2.4	1.79	5.2	5	3.8	—	3.8	10.4	19.5	20
			2.9	2.16	7.5	5	3.8	—	3.8	10.4	22.4	25
			3.7	2.76	10.2	5	3.8	—	3.8	10.4	25.8	30
CAELHEAT002A00	480-3-60	240-3-60	1.3†	0.97	7.6	5	5.0	—	5.0	12.0	24.5	25
			2.4†	1.79	11.0	5	5.0	—	5.0	12.0	28.8	35
			2.4	1.79	5.2	5	5.0	—	5.0	12.0	21.5	25
			2.9	2.16	7.5	5	5.0	—	5.0	12.0	24.4	25
			3.7	2.76	10.2	5	5.0	—	5.0	12.0	27.8	30
CAELHEAT003A00	575-3-60	480-3-60	2.4	1.79	2.6	5	5.0	—	5.0	6.00	10.8	15
			2.9	2.16	3.4	5	5.0	—	5.0	6.00	11.8	15
			3.7	2.76	4.8	5	5.0	—	5.0	6.00	13.5	15
CAELHEAT004A00	208-3-60	575-3-60	1.0	0.75	1.4	5	5.0	—	5.0	5.00	8.0	15
			2.0	1.49	2.3	5	5.0	—	5.0	5.00	9.2	15
			3.0	2.24	3.8	5	5.0	—	5.0	5.00	11.0	15
CAELHEAT005A00	240-3-60	480-3-60	1.3†	0.97	7.6	10	7.5	—	7.5	20.8	35.6	40
			2.4†	1.79	11.0	10	7.5	—	7.5	20.8	39.8	40
			2.4	1.79	5.2	10	7.5	—	7.5	20.8	32.6	35
			2.9	2.16	7.5	10	7.5	—	7.5	20.8	35.4	40
			3.7	2.76	10.2	10	7.5	—	7.5	20.8	38.8	40
CAELHEAT006A00	575-3-60	480-3-60	1.3†	0.97	7.6	10	10.0	—	10.0	24.1	39.6	40
			2.4†	1.79	11.0	10	10.0	—	10.0	24.1	43.8	50
			2.4	1.79	5.2	10	10.0	—	10.0	24.1	36.6	40
			2.9	2.16	7.5	10	10.0	—	10.0	24.1	39.4	40
			3.7	2.76	10.2	10	10.0	—	10.0	24.1	42.8	50
CAELHEAT007A00	208-3-60	575-3-60	1.0	0.75	1.4	10	10.0	—	10.0	10.0	14.3	15
			2.0	1.49	2.3	10	10.0	—	10.0	10.0	15.4	20
			3.0	2.24	3.8	10	10.0	—	10.0	10.0	17.3	20
			1.3†	0.97	7.6	15	11.3	—	11.3	31.3	48.6	50
			2.4†	1.79	11.0	15	11.3	—	11.3	31.3	52.9	60
CAELHEAT008A00	240-3-60	480-3-60	2.4	1.79	5.2	15	11.3	—	11.3	31.3	45.6	50
			2.9	2.16	7.5	15	11.3	—	11.3	31.3	48.5	50
			3.7	2.76	10.2	15	11.3	—	11.3	31.3	51.9	60
			1.3†	0.97	7.6	15	15.0	—	15.0	36.1	54.6	60
			2.4†	1.79	11.0	15	15.0	—	15.0	36.1	58.9	60
CAELHEAT009A00	575-3-60	480-3-60	2.4	1.79	2.6	15	15.0	—	15.0	18.0	25.8	30
			2.9	2.16	3.4	15	15.0	—	15.0	18.0	26.8	30
			3.7	2.76	4.8	15	15.0	—	15.0	18.0	28.6	30
CAELHEAT009A00	575-3-60	575-3-60	1.0	0.75	1.4	15	15.0	—	15.0	15.1	20.6	25
			2.0	1.49	2.3	15	15.0	—	15.0	15.1	21.7	25
			3.0	2.24	3.8	15	15.0	—	15.0	15.1	23.6	25

40RM007-028

See Legend and Notes on page 93.





40RM ELECTRIC HEATER DATA (cont)

HEATER PART NO.	UNIT	V-PH-Hz	FAN MOTOR			ELECTRIC HEATER(S)					MCA*	MOCP*
			Hp	kW	FLA	Nominal Capacity (kW)	Actual Capacity (kW)			FLA		
							Stage 1	Stage 2	Total			
CAELHEAT010A00	40RM007-012	208-3-60	1.3†	0.97	7.6	25	11.3	7.5	18.8	52.1	74.7	80
			2.4†	1.79	11.0	25	11.3	7.5	18.8	52.1	78.9	80
			2.4	1.79	5.2	25	11.3	7.5	18.8	52.1	71.7	80
			2.9	2.16	7.5	25	11.3	7.5	18.8	52.1	74.5	80
		3.7	2.76	10.2	25	11.3	7.5	18.8	52.1	77.9	80	
		240-3-60	1.3†	0.97	7.6	25	15.0	10.0	25.0	60.1	84.7	90
	2.4†		1.79	11.0	25	15.0	10.0	25.0	60.1	88.9	90	
	2.4		1.79	5.2	25	15.0	10.0	25.0	60.1	81.7	90	
	2.9		2.16	7.5	25	15.0	10.0	25.0	60.1	84.6	90	
	3.7	2.76	10.2	25	15.0	10.0	25.0	60.1	87.9	90		
	CAELHEAT011A00	480-3-60	2.4	1.79	2.6	25	15.0	10.0	25.0	30.1	40.8	50
			2.9	2.16	3.4	25	15.0	10.0	25.0	30.1	41.8	50
3.7			2.76	4.8	25	15.0	10.0	25.0	30.1	43.6	50	
CAELHEAT012A00	575-3-60	1.0	0.75	1.4	25	15.0	10.0	25.0	25.1	33.1	35	
		2.0	1.49	2.3	25	15.0	10.0	25.0	25.1	34.3	35	
		3.0	2.24	3.8	25	15.0	10.0	25.0	25.1	36.1	40	
CAELHEAT013A00	40RM008,012	208-3-60	2.4†	1.79	11.0	35	15.0	11.3	26.3	73.0	105.0	110
			2.4	1.79	5.2	35	15.0	11.3	26.3	73.0	97.7	100
			2.9	2.16	7.5	35	15.0	11.3	26.3	73.0	100.6	110
			3.7	2.76	10.2	35	15.0	11.3	26.3	73.0	104.0	110
		240-3-60	2.4†	1.79	11.0	35	20.0	15.0	35.0	84.2	119.0	125
			2.4	1.79	5.2	35	20.0	15.0	35.0	84.2	111.7	125
	2.9		2.16	7.5	35	20.0	15.0	35.0	84.2	114.6	125	
	3.7		2.76	10.2	35	20.0	15.0	35.0	84.2	118.0	125	
	CAELHEAT014A00	480-3-60	2.4	1.79	2.6	35	20.0	15.0	35.0	42.1	55.9	60
			2.9	2.16	3.4	35	20.0	15.0	35.0	42.1	56.9	60
			3.7	2.76	4.8	35	20.0	15.0	35.0	42.1	58.6	60
	CAELHEAT015A00	575-3-60	2.0	1.49	2.3	35	20.0	15.0	35.0	35.1	46.8	50
3.0			2.24	3.8	35	20.0	15.0	35.0	35.1	48.7	50	

LEGEND

- FLA** — Full Load Amps
- Hp** — Horsepower
- MCA** — Minimum Circuit Amps
- MOCP** — Maximum Overcurrent Protection (Amps)

*Values shown are for single-point connection of electric heat accessory and air handler.

†Single-phase motors. All other motors are 3-phase.

NOTES:

1. Electrical resistance heaters are rated at 240 v, 480 v, or 575 v. To determine heater capacity (kW) at unit nameplate multiply the 240-v, 480-v, or 575-v capacity (kW) by the factor shown in the table below for the unit voltage.

HEATER RATING VOLTAGE	ACTUAL HEATER VOLTAGE										
	200	208	230	240	400	440	460	480	550	575	600
240	0.694	0.751	0.918	1	—	—	—	—	—	—	—
480	—	—	—	—	0.694	0.84	0.918	1	—	—	—
575	—	—	—	—	—	—	—	—	0.915	1	1.089

2. The following equation converts kW of heat energy to Btuh: kW x 3,412 = Btuh.
3. Heater contactor coils are 24 v and require 8 va holding current.
4. Electric heaters are tested and ETL approved at maximum total external static pressure of 1.9 in. wg.
5. MCA and MOCP values apply to both standard and alternate factory-supplied motors.
6. Approximate shipping weight for CAELHEAT001A00-015A00 is 55 lb each. Approximate shipping weight for CAELHEAT016A00-027A00 is 60 lb each, CAELHEAT028A00-039A00 is 75 lb each.



40RM007-028

Electrical data (cont)



40RM ELECTRIC HEATER DATA (cont)

HEATER PART NO.	UNIT	V-PH-Hz	FAN MOTOR			ELECTRIC HEATER(S)					MCA*	MOCP*
			Hp	kW	FLA	Nominal Capacity (kW)	Actual Capacity (kW)			FLA		
							Stage 1	Stage 2	Total			
CAELHEAT016A00	40RM014-024	208-3-60	2.9	2.16	7.5	10	7.5	—	7.5	20.8	35.4	40
			3.7	2.76	10.2	10	7.5	—	7.5	20.8	38.8	40
			5.0	3.73	14.6	10	7.5	—	7.5	20.8	41.3	50
			7.5	5.59	21.5	10	7.5	—	7.5	20.8	52.9	60
CAELHEAT017A00	40RM014-024	240-3-60	2.9	2.16	7.5	10	10.0	—	10.0	24.1	39.4	40
			3.7	2.76	10.2	10	10.0	—	10.0	24.1	42.8	50
			5.0	3.73	12.8	10	10.0	—	10.0	24.1	46.1	50
			7.5	5.59	19.4	10	10.0	—	10.0	24.1	52.9	60
CAELHEAT018A00	40RM014-024	480-3-60	2.9	2.16	3.4	10	10.0	—	10.0	12.0	19.3	20
			3.7	2.76	4.8	10	10.0	—	10.0	12.0	21.0	25
			5.0	3.73	6.4	10	10.0	—	10.0	12.0	23.0	25
			7.5	5.59	9.7	10	10.0	—	10.0	12.0	27.2	30
CAELHEAT019A00	40RM014-024	575-3-60	3.0	2.24	3.8	10	10.0	—	10.0	10.0	17.3	20
			5.0	3.73	5.1	10	10.0	—	10.0	10.0	19.6	20
			7.5	5.59	7.8	10	10.0	—	10.0	10.0	22.1	25
			10.0	7.37	10.5	10	10.0	—	10.0	10.0	24.6	30
CAELHEAT020A00	40RM014-024	208-3-60	2.9	2.16	7.5	20	14.9	—	14.9	41.5	51.2	70
			3.7	2.76	10.2	20	14.9	—	14.9	41.5	64.6	70
			5.0	3.73	14.6	20	14.9	—	14.9	41.5	70.1	80
			7.5	5.59	21.5	20	14.9	—	14.9	41.5	78.7	80
CAELHEAT021A00	40RM014-024	240-3-60	2.9	2.16	7.5	20	19.9	—	19.9	47.9	69.2	70
			3.7	2.76	10.2	20	19.9	—	19.9	47.9	72.6	80
			5.0	3.73	12.8	20	19.9	—	19.9	47.9	75.8	80
			7.5	5.59	19.4	20	19.9	—	19.9	47.9	84.1	80
CAELHEAT022A00	40RM014-024	480-3-60	2.9	2.16	3.4	20	20.0	—	20.0	24.1	34.3	35
			3.7	2.76	4.8	20	20.0	—	20.0	24.1	36.1	40
			5.0	3.73	6.4	20	20.0	—	20.0	24.1	39.1	40
			7.5	5.59	9.7	20	20.0	—	20.0	24.1	43.2	50
CAELHEAT023A00	40RM014-024	575-3-60	3.0	2.24	3.8	20	20.0	—	20.0	20.1	29.9	30
			5.0	3.73	5.1	20	20.0	—	20.0	20.1	31.5	35
			7.5	5.59	7.8	20	20.0	—	20.0	20.1	34.9	35
			10.0	7.37	10.5	20	20.0	—	20.0	20.1	37.3	40
CAELHEAT024A00	40RM014-024	208-3-60	2.9	2.16	7.5	30	15.0	7.5	22.5	62.5	87.5	90
			3.7	2.76	10.2	30	15.0	7.5	22.5	62.5	90.9	100
			5.0	3.73	14.6	30	15.0	7.5	22.5	62.5	96.4	100
			7.5	5.59	21.5	30	15.0	7.5	22.5	62.5	105.0	110
CAELHEAT025A00	40RM014-024	240-3-60	2.9	2.16	7.5	30	20.0	10.0	30.0	72.2	99.6	100
			3.7	2.76	10.2	30	20.0	10.0	30.0	72.2	103.0	110
			5.0	3.73	12.8	30	20.0	10.0	30.0	72.2	106.2	110
			7.5	5.59	19.4	30	20.0	10.0	30.0	72.2	114.5	125
CAELHEAT026A00	40RM014-024	480-3-60	2.9	2.16	3.4	30	20.0	10.0	30.0	36.1	49.4	50
			3.7	2.76	4.8	30	20.0	10.0	30.0	36.1	51.1	60
			5.0	3.73	6.4	30	20.0	10.0	30.0	36.1	53.1	60
			7.5	5.59	9.7	30	20.0	10.0	30.0	36.1	57.2	60
CAELHEAT027A00	40RM014-024	575-3-60	3.0	2.24	3.8	30	20.0	10.0	30.0	30.1	42.4	50
			5.0	3.73	5.1	30	20.0	10.0	30.0	30.1	44.0	50
			7.5	5.59	7.8	30	20.0	10.0	30.0	30.1	47.4	50
			10.0	7.37	10.5	30	20.0	10.0	30.0	30.1	49.8	60

40RM007-028

See Legend and Notes on page 95.



40RM ELECTRIC HEATER DATA (cont)

HEATER PART NO.	UNIT	V-PH-Hz	FAN MOTOR			ELECTRIC HEATER(S)						MCA*	MOCP*
			Hp	kW	FLA	Nominal Capacity (kW)	Actual Capacity (kW)			FLA			
							Stage 1	Stage 2	Total				
CAELHEAT025A00	40RM016,024	208-3-60	3.7	2.76	10.2	50	22.6	15.0	37.6	104.3	143.1	150	
			5.0	3.73	14.6	50	22.6	15.0	37.6	104.3	148.6	150	
			7.5	5.59	21.5	50	22.6	15.0	37.6	104.3	157.2	175	
		240-3-60	3.7	2.76	10.2	50	30.0	20.0	50.0	120.3	163.1	175	
			5.0	3.73	12.8	50	30.0	20.0	50.0	120.3	166.4	175	
			7.5	5.59	19.4	50	30.0	20.0	50.0	120.3	174.6	200	
CAELHEAT026A00	480-3-60	3.7	2.76	4.8	50	30.0	20.0	50.0	60.1	81.2	90		
		5.0	3.73	6.4	50	30.0	20.0	50.0	60.1	83.2	90		
		7.5	5.59	9.7	50	30.0	20.0	50.0	60.1	87.3	90		
CAELHEAT027A00	575-3-60	3.0	2.24	3.8	50	30.0	20.0	50.0	50.2	67.5	70		
		5.0	3.73	5.1	50	30.0	20.0	50.0	50.2	69.1	70		
		7.5	5.59	7.8	50	30.0	20.0	50.0	50.2	72.5	80		
CAELHEAT028A00	208-3-60	7.5	5.59	19.8	20	14.9	—	14.9	41.5	78.7	80		
		10.0	7.46	28.2	20	14.9	—	14.9	41.5	87.1	100		
CAELHEAT029A00	240-3-60	7.5	5.59	19.4	20	19.9	—	19.9	47.9	81.4	90		
		10.0	7.46	26.8	20	19.9	—	19.9	47.9	93.3	110		
CAELHEAT030A00	480-3-60	7.5	5.59	9.7	20	20.0	—	20.0	24.1	42.2	50		
		10.0	7.46	13.4	20	20.0	—	20.0	24.1	46.8	50		
CAELHEAT031A00	575-3-60	7.5	5.59	7.8	20	20.0	—	20.0	20.1	34.9	35		
		10.0	7.46	10.3	20	20.0	—	20.0	20.1	38.0	40		
CAELHEAT032A00	208-3-60	7.5	5.59	19.8	40	15.0	15.0	30.0	83.4	131.1	150		
		10.0	7.46	28.0	40	15.0	15.0	30.0	83.4	139.5	150		
CAELHEAT033A00	240-3-60	7.5	5.59	19.4	40	20.0	20.0	40.0	96.2	144.5	150		
		10.0	7.46	26.8	40	20.0	20.0	40.0	96.2	153.8	175		
CAELHEAT032A00	480-3-60	7.5	5.59	9.7	40	20.0	20.0	40.0	47.9	71.9	80		
		10.0	7.46	13.4	40	20.0	20.0	40.0	47.9	76.6	80		
CAELHEAT033A00	575-3-60	7.5	5.59	7.8	40	20.0	20.0	40.0	40.2	60.0	60		
		10.0	7.46	10.3	40	20.0	20.0	40.0	40.2	63.1	70		

LEGEND

- FLA** — Full Load Amps
- Hp** — Horsepower
- MCA** — Minimum Circuit Amps
- MOCP** — Maximum Overcurrent Protection (Amps)

*Values shown are for single-point connection of electric heat accessory and air handler.
 †Single-phase motors. All other motors are 3-phase.

NOTES:

1. Electrical resistance heaters are rated at 240 v, 480 v, or 575 v. To determine heater capacity (kW) at unit nameplate multiply the 240-v, 480-v, or 575-v capacity (kW) by the factor shown in the table below for the unit voltage.

HEATER RATING VOLTAGE	ACTUAL HEATER VOLTAGE										
	200	208	230	240	400	440	460	480	550	575	600
240	0.694	0.751	0.918	1	—	—	—	—	—	—	—
480	—	—	—	—	0.694	0.84	0.918	1	—	—	—
575	—	—	—	—	—	—	—	—	0.915	1	1.089

2. The following equation converts kW of heat energy to Btuh: kW x 3,412 = Btuh.
3. Heater contactor coils are 24 v and require 8 va holding current.
4. Electric heaters are tested and ETL approved at maximum total external static pressure of 1.9 in. wg.
5. MCA and MOCP values apply to both standard and alternate factory-supplied motors.
6. Approximate shipping weight for CAELHEAT001A00-015A00 is 55 lb each. Approximate shipping weight for CAELHEAT016A00-027A00 is 60 lb each, CAELHEAT028A00-039A00 is 75 lb each.



40RM007-028

Electrical data (cont)



40RM ELECTRIC HEATER DATA (cont)

HEATER PART NO.	UNIT	V-PH-Hz	FAN MOTOR			ELECTRIC HEATER(S)					MCA*	MOCP*
			Hp	kW	FLA	Nominal Capacity (kW)	Actual Capacity (kW)			FLA		
							Stage 1	Stage 2	Total			
CAELHEAT034A00	40RM028	208-3-60	7.5	5.59	19.8	50	22.6	15.0	37.6	104.3	157.2	175
			10.0	7.46	28.0	50	22.6	15.0	37.6	104.3	165.6	175
240-3-60		7.5	5.59	19.4	50	30.0	20.0	50.0	120.3	174.6	200	
		10.0	7.46	26.8	50	30.0	20.0	50.0	120.3	183.9	200	
CAELHEAT035A00		480-3-60	7.5	5.59	9.7	50	30.0	20.0	50.0	60.1	87.3	90
CAELHEAT036A00			10.0	7.46	13.4	50	30.0	20.0	50.0	60.1	91.9	100
CAELHEAT037A00		575-3-60	7.5	5.59	7.8	50	30.0	20.0	50.0	50.2	72.5	80
			10.0	7.46	10.3	50	30.0	20.0	50.0	50.2	75.6	80
CAELHEAT038A00		208-3-60	7.5	5.59	19.8	70	30.0	22.6	52.6	145.9	172.8	175
			10.0	7.46	28.0	70	30.0	22.6	52.6	145.9	181.2	200
CAELHEAT039A00		240-3-60	7.5	5.59	19.4	70	40.0	30.0	70.0	168.4	192.6	200
			10.0	7.46	26.8	70	40.0	30.0	70.0	168.4	201.9	225
CAELHEAT038A00	480-3-60	7.5	5.59	9.7	70	40.0	30.0	70.0	84.2	96.3	100	
		10.0	7.46	13.4	70	40.0	30.0	70.0	84.2	100.9	110	
CAELHEAT039A00	575-3-60	7.5	5.59	7.8	70	40.0	30.0	70.0	70.3	80.0	90	
		10.0	7.46	10.3	70	40.0	30.0	70.0	70.3	83.2	90	

LEGEND

- FLA** — Full Load Amps
- Hp** — Horsepower
- MCA** — Minimum Circuit Amps
- MOCP** — Maximum Overcurrent Protection (Amps)

*Values shown are for single-point connection of electric heat accessory and air handler.

†Single-phase motors. All other motors are 3-phase.

NOTES:

1. Electrical resistance heaters are rated at 240 v, 480 v, or 575 v. To determine heater capacity (kW) at unit nameplate multiply the 240-v, 480-v, or 575-v capacity (kW) by the factor shown in the table below for the unit voltage.

HEATER RATING VOLTAGE	ACTUAL HEATER VOLTAGE										
	200	208	230	240	400	440	460	480	550	575	600
240	0.694	0.751	0.918	1	—	—	—	—	—	—	—
480	—	—	—	—	0.694	0.84	0.918	1	—	—	—
575	—	—	—	—	—	—	—	—	0.915	1	1.089

2. The following equation converts kW of heat energy to Btuh: kW x 3,412 = Btuh.
3. Heater contactor coils are 24 v and require 8 va holding current.
4. Electric heaters are tested and ETL approved at maximum total external static pressure of 1.9 in. wg.
5. MCA and MOCP values apply to both standard and alternate factory-supplied motors.
6. Approximate shipping weight for CAELHEAT001A00-015A00 is 55 lb each. Approximate shipping weight for CAELHEAT016A00-027A00 is 60 lb each, CAELHEAT028A00-039A00 is 75 lb each.



40RM007-028

Application data



Operating limits

Maximum fan speed — 40RM007-024 1200 rpm

Maximum fan speed — 40RM028 1100 rpm

General

Select equipment to match or to be slightly less than peak load. This provides better humidity control, less unit cycling, and less part-load operation. Equipment should be selected to perform at no less than 300 cfm/ton.

The air handler fan must always be operating when the condensing unit is operating.

Ductwork should be sized according to unit size, not building load. For larger units with two fans, a split duct transition is recommended at the fan outlets, but a plenum can be used with slight reduction in external static pressure capability.

For variable air volume (VAV) systems with supply-to-return air recycling, use the equipment room as a return air plenum.

FACTORY-INSTALLED NOZZLE AND DISTRIBUTOR DATA

UNIT	COIL TYPE	TXV Qty...Part No.*	DISTRIBUTOR Qty...Part No.†	FEEDER TUBES PER DISTRIBUTOR Qty...Size (in.)	NOZZLE Qty...Part No.
40RM007	3, 4 Row	1...TDEBX8	1...1116	12... ¹ / ₄	1...E5
40RM008	3, 4 Row	1...TDEBX8	1...1126	15... ¹ / ₄	1...C6
40RM012	3, 4 Row	2...TDEX6	2...1115	9... ¹ / ₄	2...E4
40RM014	3 Row	2...TDEBX8	2...1115	9... ¹ / ₄	2...E5
	4 Row	2...TDEBX8	2...1115	12... ³ / ₁₆	2...E5
40RM016	3 Row	2...TDEBX8	2...1116	12... ¹ / ₄	2...E6
	4 Row	2...TDEBX8	2...1126	16... ¹ / ₄	2...C6
40RM024	3 Row	2...TDEBX11	2...1116	13... ¹ / ₄	2...E8
	4 Row	2...TDEBX11	2...1126	18... ³ / ₁₆	2...C8
40RM028	3 Row	2...TDEBX11	2...1126	15... ¹ / ₄	2...C10
	4 Row	2...TDEBX11	2...1126	20... ³ / ₁₆	2...C15

*Danfoss part numbers shown.

†Sporlan Valve Co. part numbers shown.

40RM007-028

Application data (cont)



FAN MOTOR DATA UNIT 40RM — STANDARD MOTOR

UNIT 40RM	007	008	012	014	016	024	028
208/230-1-60							
Speed (rpm)	1725	1725	—	—	—	—	—
Hp	1.3	2.4	—	—	—	—	—
Frame (NEMA)	56Y	56Y	—	—	—	—	—
Shaft Dia (in.)	5/8	5/8	—	—	—	—	—
208/230-3-60 and 460-3-60							
Speed (rpm)	1725	1725	1725	1725	1725	1745	1745
Hp	2.4	2.4	2.4	2.9	3.7	5.0	7.5
Frame (NEMA)	56Y	56Y	56Y	56Y	56Y	S184T	S213T
Shaft Dia (in.)	5/8	5/8	5/8	7/8	7/8	1 1/8	1 3/8
575-3-60							
Speed (rpm)	1725	1725	1725	1725	1725	1745	1755
Hp	1.0	2.0	2.0	3.0	3.0	5.0	7.5
Frame (NEMA)	56	56HZ	56HZ	56HZ	56HZ	184T	S213T
Shaft Dia (in.)	5/8	7/8	7/8	7/8	7/8	1 1/8	1 3/8

LEGEND

NEMA — National Electrical Manufacturers Association

UNIT 40RM — ALTERNATE MOTOR

UNIT 40RM	007	008	012	014	016	024	028
208/230-1-60							
Speed (rpm)	1725	1725	—	—	—	—	—
Hp	2.4	2.4	—	—	—	—	—
Frame (NEMA)	56Y	56Y	—	—	—	—	—
Shaft Dia (in.)	5/8	7/8	—	—	—	—	—
230-3-60 and 460-3-60							
Speed (rpm)	1725	1725	1725	1725	1725	1745	1745
Hp	2.9	2.9	3.7	3.7	5.0	7.5	10.0
Frame (NEMA)	56Y	56Y	Y56Y	Y56Y	S184T	S213T	S215T
Shaft Dia (in.)	7/8	7/8	7/8	7/8	1 1/8	1 3/8	1 3/8
575-3-60							
Speed (rpm)	1725	1725	1725	1745	1745	1755	1750
Hp	2.0	3.0	3.0	5.0	5.0	7.5	10.0
Frame (NEMA)	56HZ	56HZ	56HZ	184T	184T	S213T	D215T
Shaft Dia (in.)	7/8	7/8	7/8	1 1/8	1 1/8	1 3/8	1 3/8

LEGEND

NEMA — National Electrical Manufacturers Association

40RM007-028



UNIT 40RM — STANDARD DRIVE DATA

UNIT 40RM	007	008	012	014	016	024	028
MOTOR DRIVE							
Motor Pulley Pitch Diameter (in.)	2.4-3.4	2.8-3.8	3.4-4.4	2.8-3.8	2.8-3.8	3.7-4.7	4.3-5.3
Pulley Factory Setting Full Turns Open	2.5	2.5	2.5	2.5	2.5	3.0	3.0
FAN DRIVE							
Pulley Pitch Dia (in.)	8.8	8.8	8.8	9.0	9.0	9.4	11.0
Pulley Bore (in.)	1	1	1	1 ^{7/16}	1 ^{7/16}	1 ^{7/16}	1 ^{15/16}
Belt No. — Section	1—A	1—A	1—A	1—A	1—A	2—B	2—B*
Belt Pitch (in.)	40.3	41.3	42.3	42.3	42.3	41.8	(2) 42.8 (2) 43.8
FAN SPEEDS (rpm)							
Factory Settings	568	647	764	632	632	771	752
Range	470-666	549-745	666-863	537-728	537-728	679-863	682-841
Max Allowable Speed (rpm)	1200	1200	1200	1200	1200	1200	1100
Change per 1/2 turn of Moveable Motor Pulley Flange	19.6	19.6	19.7	19.1	19.1	15.3	13.1
MAX FULL TURNS FROM CLOSED POSITION							
	5	5	5	5	5	6	6
SHAFTS CENTER DISTANCE (in.)							
	10.44- 12.32	10.44- 12.32	10.44- 12.32	10.44- 12.32	10.44- 12.32	9.12- 10.99	6.67- 9.43

*Four belts shipped with unit. Use correct set of 2 belts sized according to the pulley setting.

UNIT 40RM — MEDIUM-STATIC DRIVE DATA

UNIT 40RM	007	008	012	014	016	024	028
MOTOR DRIVE							
Motor Pulley Pitch Diameter (in.)	3.4-4.4	3.4-4.4	3.4-4.4	3.4-4.4	3.7-4.7	4.3-5.3	4.3-5.3
Pulley Factory Setting Full Turns Open	2.5	2.5	2.5	2.5	3.0	3.0	3.0
FAN DRIVE							
Pulley Pitch Dia (in.)	8.8	8.0	8.0	8.2	8.6	9.4	9.4
Pulley Bore (in.)	1	1	1	1 ^{7/16}	1 ^{7/16}	1 ^{7/16}	1 ^{15/16}
Belt No. — Section	1—A	1—A	1—A	1—A	1—B	2—B	2—B*
Belt Pitch (in.)	42.3	40.3	40.3	41.3	41.8	41.8	(2) 38.8 (2) 39.8
FAN SPEEDS (rpm)							
Factory Setting	764	841	841	820	842	881	881
Range	666-863	733-949	733-949	715-926	742-943	798-984	798-984
Max Allowable Speed (rpm)	1200	1200	1200	1200	1200	1200	1100
Change per 1/2 Turn of Moveable Motor Pulley Flange	19.7	21.6	21.6	21.1	16.7	15.3	15.3
MAX FULL TURNS FROM CLOSED POSITION							
	5	5	5	5	6	6	6
SHAFTS CENTER DISTANCE (in.)							
	10.44- 12.32	10.44- 12.32	10.44- 12.32	10.44- 12.32	10.44- 12.32	9.16- 10.99	6.67- 9.43

*Four belts shipped with unit. Use correct set of 2 belts sized according to the pulley setting.

40RM007-028

Application data (cont)



UNIT 40RM — HIGH-STATIC DRIVE DATA

UNIT 40RM	007	008	012	014	016	024	028
MOTOR DRIVE							
Motor Pulley Pitch Diameter (in.)	3.4-4.4	3.4-4.4	3.4-4.4	3.7-4.7	4.3-5.3	4.3-5.3	4.3-5.3
Pulley Factory Setting Full Turns Open	2.5	2.5	2.5	3.0	3.0	3.0	3.0
FAN DRIVE							
Pulley Pitch Dia (in.)	7.0	6.0*	6.0	7.4	7.9	7.4	8.6
Pulley Bore (in.)	1	1	1	1 ^{7/16}	1 ^{7/16}	1 ^{7/16}	1 ^{15/16}
Belt No. — Section	1—A	1—A	1—A	1—B	1—B	2—B	2—B
Belt Pitch (in.)	41.3	37.3	37.3	39.8	39.8	36.8	37.8
FAN SPEEDS (rpm)							
Factory Setting	961	1121	1121	979	1060	1118	1024
Range	838-1084	978-1200*†	978-1200†	873-1096	950-1171	1014-1200†	873-1075
Max Allowable Speed (rpm)	1200	1200	1200	1200	1200	1200	1100
Change per 1/2 Turn of Moveable Motor Pulley Flange	24.6	28.7	28.7	19.4	18.4	19.4	16.7
MAX FULL TURNS FROM CLOSED POSITION							
	5	5	5	6	6	6	6
SHAFTS CENTER DISTANCE (in.)							
	10.44-12.32	10.44-12.32	10.44-12.32	10.44-12.32**	9.16-10.99	8.16-10.02	6.67-9.43

*Values for 3-phase motor shown. For single-phase motor, pulley pitch diameter is 7 in. and resulting fan speed is 837-1096 rpm.

†It is possible to adjust drive so that fan speed exceeds maximum allowable. DO NOT exceed 1200 rpm.

**575-v unit has a center distance of 9.16-10.99.

Commercial Packaged Air-Handling Unit

HVAC Guide Specifications

Size Range: **2,400 to 10,000 Cfm, Nominal Airflow
6 to 25 Tons, Nominal Cooling**

Carrier Model Number: **40RM (Direct-Expansion Coil)**

Part 1 — General

1.01 SYSTEM DESCRIPTION

- A. Indoor, packaged air-handling unit for use in commercial split systems. Unit shall have a multipoise design and shall be capable of horizontal or vertical installation on a floor or in a ceiling, with or without ductwork. (Only vertical units are to be applied without ductwork.)
- B. Unit shall have a direct-expansion coil and shall be used in a refrigerant circuit with a matching air-cooled condensing unit.

1.02 QUALITY ASSURANCE

- A. Coils shall be designed and tested in accordance with ASHRAE 15 Safety Code for Mechanical Refrigeration, latest edition.
- B. Unit shall be constructed in accordance with ETL and ETL, Canada standards and shall carry the ETL and ETL, Canada labels.
- C. Unit insulation and adhesive shall comply with NFPA-90A requirements for flame spread and smoke generation. Insulation shall contain an EPA-registered immobilized antimicrobial agent to effectively resist the growth of bacteria and fungi as proven by tests in accordance with ASTM standards G21 and 22.
- D. Unit shall be manufactured in a facility registered to the ISO 9001:2000 manufacturing quality standard.
- E. Direct-expansion coils shall be burst tested at 435 psi and leak tested at 150 psi.

1.03 DELIVERY AND STORAGE

Units shall be stored and handled per manufacturer's recommendations.

1.04 WARRANTY (FOR INCLUSION BY SPECIFYING ENGINEER)

Part 2 — Products

2.01 EQUIPMENT

Indoor mounted, draw-thru, packaged air-handling unit that can be used with or without ductwork in a suspended horizontal configuration or free-standing vertical configuration. Unit shall consist of forward-curved belt-driven centrifugal fan(s), motor and drive assembly, prewired fan motor contactor, factory-installed refrigerant metering devices, cooling coil, 2-in. disposable air filters, and condensate drain pans for vertical or horizontal configurations.

- A. Base Unit:
 1. Cabinet shall be constructed of mill-galvanized steel.

2. Cabinet panels shall be fully insulated with 1/2-in. fire-retardant material. Insulation shall contain an EPA-registered immobilized antimicrobial agent to effectively resist the growth of bacteria and fungi as proven by tests in accordance with ASTM standards G21 and 22.
3. Unit shall contain non-corroding condensate drain pans for both vertical and horizontal applications. Drain pans shall have connections on right and left sides of unit to facilitate field connection. Drain pans shall have the ability to be sloped toward the right or left side of the unit to prevent standing water from accumulating in pans.
4. Unit shall have factory-supplied 2-in. throwaway-type filters installed upstream from the cooling coil. Filter access shall be from either the right or left side of the unit.

B. Coils:

Coils shall consist of 3 rows (standard) or 4 rows (high capacity) of 3/8-in. copper tubes with sine-wave aluminum fins bonded to the tubes by mechanical expansion. Coil tubing shall be internally rifled to maximize heat transfer. Suction and liquid line connections shall be made on the same side of the coil. Direct-expansion coils shall feature factory-installed thermostatic expansion valves (TXVs) for refrigerant control. The TXVs shall be capable of external adjustment.

C. Operating Characteristics:

Unit shall be capable of providing _____ cfm airflow at an external static pressure of _____ in. wg.

D. Motor:

Fan motor of the size and electrical characteristics specified on the equipment schedule shall be factory supplied and installed.

E. Special Features:

1. Alternate Motor and Drive:

An alternate motor and medium- or high-static drive shall be available to meet the airflow and external static pressure requirements specified on the equipment schedule.

2. High-Capacity Coil:

High-capacity coil consisting of 4 rows of 3/8-in. copper tubes with sine-wave aluminum fins bonded to the tubes by mechanical expansion. Coil tubing shall be internally rifled to maximize heat transfer. Suction and liquid line connections shall be made on the same side of the coil. Direct-expansion coils shall feature factory-installed thermostatic expansion valves (TXVs) for refrigerant control. The TXVs shall be capable of external adjustment.

3. External Paint:

Where conditions require, units shall be painted with an American Sterling Gray finish.



4. Hot Water Coil:

Coil shall be 2-row, U-bend coil with copper tubes and aluminum plate fins bonded to the tubes by mechanical expansion. Coil shall be mounted in a galvanized steel housing that shall be fastened to the unit's fan deck for blow-thru heating operation. Coil shall have maximum working pressure of 150 psig.

5. Steam Distributing Coil:

Coil shall consist of one row of copper tubes with aluminum plate fins, and shall have inner steam distributing tubes. Coil shall be mounted in a galvanized steel housing and shall be fastened to the unit's fan deck for blow-thru heating operation. Coil shall have maximum working pressure of 20 psig at 260 F.

6. Electric Heaters:

Heaters for nominal 240, 480, or 575-volt, 3-phase, 60 Hz power supply shall be factory-supplied for field installation as shown on the equipment drawings. Electric heat assembly shall be ETL agency approved, and shall have single-point power wiring. Heater assembly shall include contactors with 24-v coils, power wiring, 24-v control wiring terminal blocks, and a hinged access panel.

7. Air Discharge Plenum:

Plenum shall be factory supplied to provide free-blow air distribution for vertical floor-mounted units. A grille with moveable vanes for horizontal or vertical airflow adjustment shall be included. Plenum housing shall be field-installed on the unit's fan deck for blow-thru air distribution.

8. Return-Air Grille:

Grille shall be factory supplied for field installation on the unit's return air opening.

9. Unit Subbase:

Subbase assembly shall be factory supplied for field installation. Subbase shall elevate floor-mounted vertical units to provide access for correct condensate drain connection.

10. Economizer:

Economizer for ventilation or "free" cooling shall be factory provided for field installation. For free cooling applications, economizer shall be compatible with factory-supplied thermostat; economizer dampers shall open when outdoor air enthalpy is suitable for free cooling. Economizer shall be compatible with factory-supplied CO₂ sensor; economizer dampers shall open when indoor CO₂ level rises above predetermined set point.

11. Thermostat Controls:

a. Programmable multi-stage thermostat with 7-day clock, holiday scheduling, large backlit

display, remote sensor capability, and Title 24 compliance.

b. Commercial Electronic Thermostat with 7-day timeclock, auto-changeover, multi-stage capability, and large LCD temperature display.

c. Non-programmable thermostat with fan switch subbase.

12. Overhead Suspension Package:

Package shall include necessary brackets to support units in a horizontal ceiling installation.

13. CO₂ Sensor:

Sensor shall provide the ability to signal the economizer to open when the space CO₂ level exceeds the predetermined set point.

14. Condensate Drain Trap:

Trap shall have transparent, serviceable design for easy cleaning. Kit shall include overflow shutoff switch and wiring harness for connection to an alarm if desired.

15. UV-C Germicidal Lamps:

a. UV-C emitters and fixtures shall be specifically designed for use inside an HVAC system. An ASME nozzleed test apparatus using a 45 F (7.2 C) airstream moving at not less than 400 fpm (189 liters/sec.) shall measure individual lamp output. Lamp output at 253.7 nm shall not be less than 10μW/cm² per inch of arc length measured at a distance of one meter.

b. UV-C power supplies shall be high efficiency, electric type which are matched to the emitters and are capable of producing the specified output intensity with an input power no more than 80 watts.

c. Emitters and fixtures shall be installed in sufficient quantity and arranged so as to provide an equal distribution of UV-C energy on the coil and drain pan.

d. The minimum UV-C energy striking the leading edge of the coil fins shall be not less than 820 μW/cm² at the closest point and through placement, not less than 60% of that value at the farthest point. Equal amounts are to strike the drain pan, either directly or indirectly through reflection.

e. Emitters and fixtures shall be installed at right angles to the conforming lines of the coil fins, such that through incident angle reflection, UV-C energy strikes all target surfaces of the coil, drain pan, and the available line of sight airstream.

Model number nomenclature — 28CB,LA008,012

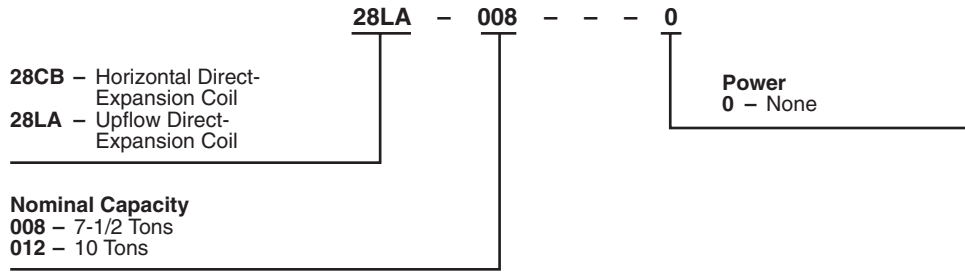

Physical data

28CB, 28LA

UNIT	28CB		28LA	
	008	012	008	012
OPERATING WT (lb)	90	125	100	142
REFRIGERANT	R-22			
DISTRIBUTOR NOZZLE Size	J5*	G8*	G8†	E10†
COIL				
Face Area (sq ft)	7.37	10.35	7.44	9.79
Rows...Fins/in.	3...11		3...12	
AIR QUANTITY (Cfm)				
Nominal	3000	4000	3000	4000
Range	2250-3375**	3000-4650**	2250-3375**	3000-4500**

*Refrigerant control is field supplied.

†Refrigerant control is factory installed (including TXV [thermostatic expansion valve]).

**Air quantities in excess of values shown may result in moisture blow-off.

Dimensions



28CB, 28LA

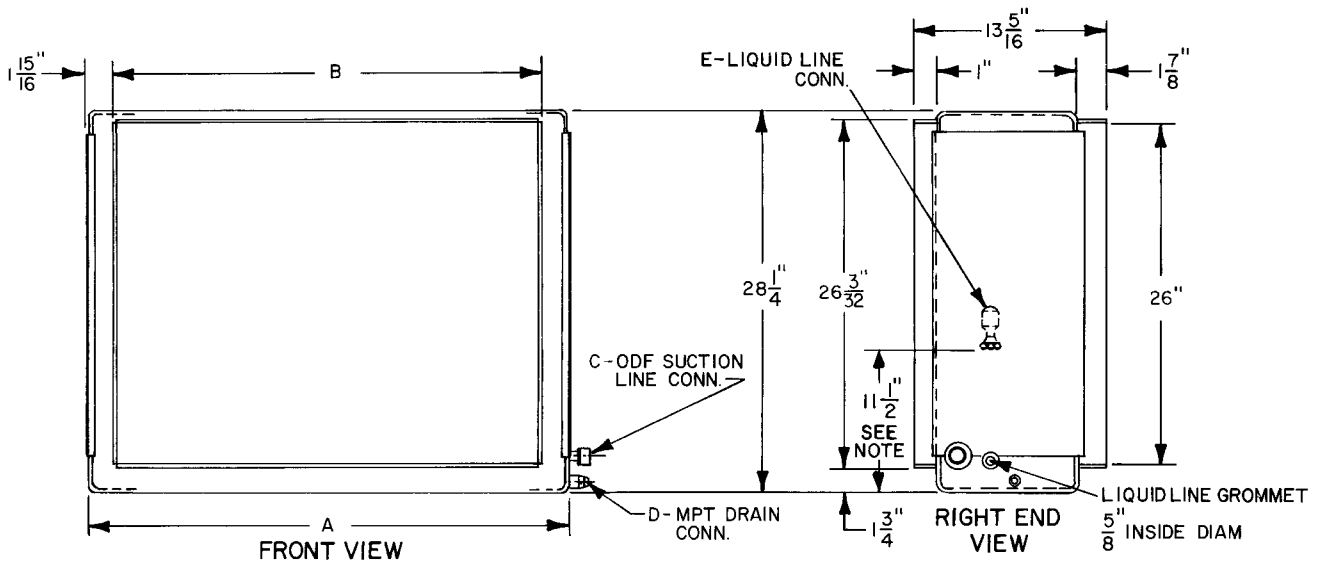

28CB

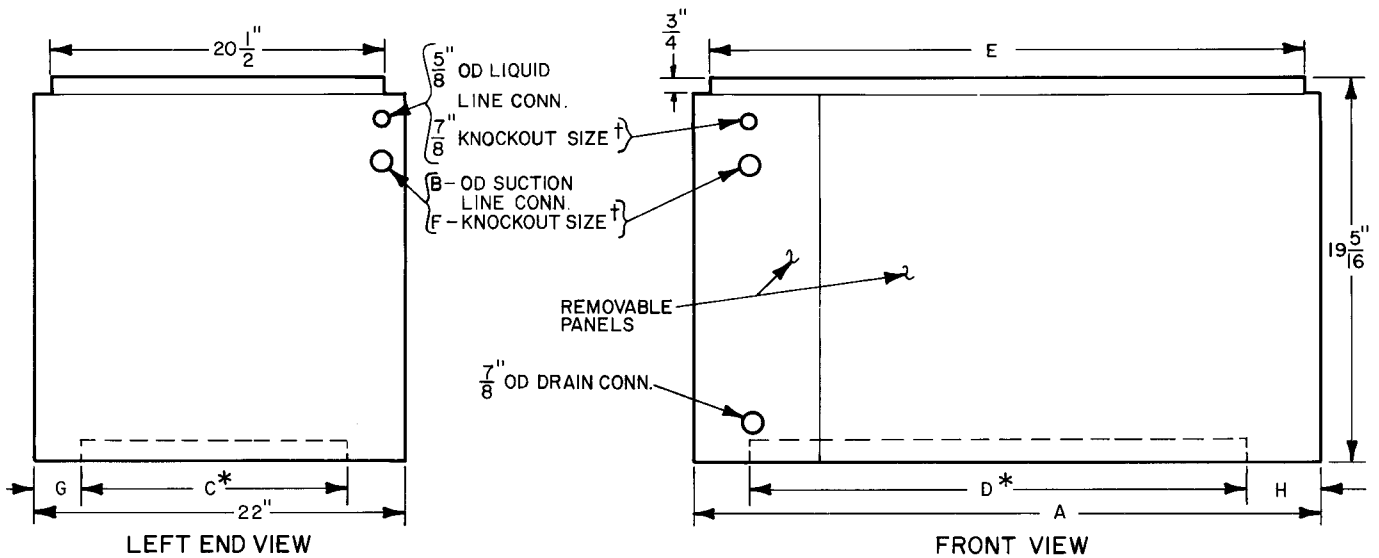

28LA

*Inlet flange dimensions.

†Left and right ends have optional knockouts.

NOTE: Unit 28CB012 is supplied with 7/8 in. ODF to 5/8 in. SAE flare nut adapter for use with field-supplied expansion valve.

UNIT 28	A	B	C	D	E	F	G	H
CB008	48	44 ¹ / ₈	1 ¹ / ₈	3/4	5/8	—	—	—
CB012	64	60 ¹ / ₈	1 ³ / ₈	1	7/8	—	—	—
LA008	42	1 ¹ / ₈	15 ¹ / ₂	35 ⁵ / ₈	40 ¹ / ₂	1 ⁵ / ₈	3 ¹ / ₄	3 ³ / ₁₆
LA012	53	1 ³ / ₈	13 ⁷ / ₈	48 ⁵ / ₈	51 ¹ / ₂	1 ³ / ₄	4 ¹ / ₁₆	2 ³ / ₁₆

28CB, LA008-012

Guide specifications — 28CB,LA008 and 012



Commercial Direct-Expansion Coils

HVAC Guide Specifications

Size Range: **3000 to 4000 Cfm, Nominal Airflow**
7¹/₂ and 10 Tons, Nominal Cooling

Carrier Model Numbers: **28CB, 28LA**

Furnish and install a _____ direct-expansion cooling coil in the location and manner shown on the plan.

Total cooling capacity of the coil shall be _____ Btuh or greater and sensible capacity shall be _____ Btuh or greater with _____ cfm of air entering coil at _____ F wet-bulb and _____ F dry-bulb. Coil refrigerant temperature shall be _____ F.

Cooling coil shall have a face area of not less than _____ sq ft and be constructed with aluminum plate fins mechanically bonded to nonferrous tubing with all joints brazed. Coil shall be _____ rows deep with a nominal fin spacing of _____ fins per inch.

The casing of encased coils shall be insulated and finished with baked enamel or equivalent corrosion-resistant surface. The casing material shall be cold-rolled steel (28LA) or galvanized steel (28CB). The 28CB coil casing shall allow space for attaching field-supplied thermostatic expansion valve.

Maximum unit dimensions shall be width of _____ in., depth of _____ in., and overall height of _____ inches.

Index



28CB,LA008,012 section 103-105
38AR007-012 section 15-41
38ARD,AKS014-024 section 42-79
40RM007-028 section 80-102
Alternate motors and drives 7, 91, 98-100
Application data
 38AR007-012 34
 38ARD,AKS014-024 69-71
 40RM007-028 97-100
ARI capacity ratings 4
CO₂ sensor 7
Combination ratings
 38AR007-012/40RM 20, 21, 23-25, 27-32
 38AR007-012/28CB,LA 22, 26
 38ARD,AKS014-024/40RM 50-67
Condenser coil grille 5
Condensing unit ratings 19, 48, 49
Controls 11
Control wiring 12
Convenience outlet 5
Copper coils 5
Dimensions
 Base unit
 28CB,LA008,012 104
 38AR007-012 17, 18
 38ARD,AKS014-024 45-47
 40RM007-028 82-84
 Discharge plenum 7, 9
 E-coated coils 5
 Economizer 7, 9
 Electrical data
 38AR007-012 33
 38ARD,AKS014-024 68
 40RM007-028 91-96
 Electric heat 7, 92-96
 Enviro-Shield[™] options 5
 Fan performance tables
 40RM007-028 85-88
 Features/Benefits 1-3
 Gage panel 5
 Guide specifications
 28CB,LA008,012 105
 38AR007-012 36-41
 38ARD,AKS014-024 74-79
 40RM007-028 101, 102
 Hail guard 5
 Hot water coil 7, 9, 90
 Hydronic heat 90
 Indoor-air quality (IAQ) 2
 Liquid line piping 34, 69
 Low ambient controls 5
 Maximum temperature 34, 69
 Minimum ambient operating temperature 34, 69
 Minimum temperature 34, 69
 Model number nomenclature
 28CB,LA008,012 103
 38AR007-012 15
 38ARD,AKS014-024 42
 40RM007-028 80
Motormaster[®] options 5
Operating sequence 11
Options and accessories 5-9
 38AR,AKS 5, 6, 8
 40RM 7, 9
Performance data
 38AR007-012 19-32
 38ARD,AKS014-024 48-67
 40RM007-028 85-90
Physical data
 28CB,LA008,012 103
 38AR007-012 16
 38ARD,AKS014-024 43, 44
 40RM007-028 81
Piping and wiring
 38AR007-012 35
 38ARD,AKS014-024 72, 73
PremierLink[™] controller 5, 8, 12
Refrigerant charge 34
Refrigerant piping 34, 70
Return-air grille 7
Selection procedure 10
Sound data 4
Static pressure drop
 Filter 89
 Economizer 90
 Heating coil 90
 Plenum 90
Steam coil 7, 9, 90
Subbase 7, 9
Thermostat 5, 8
Thermostatic expansion valve (TXV) 34, 97
Unloader package 5
Unit-mounted non-fused disconnect 5
UV-C germicidal lamps 7, 9
Wiring 12-14

